



USE AND MAINTENANCE MANUAL

CONTROL AND MANAGEMENT KIT FOR METERING PUMPS

PRO



ATTENTION:

Industrial machinery not intended for use by non-professional operators. These instructions are intended for qualified personnel.



Doc. No. UT-5601	Rev. 1	Lang. EN	1 st Issue 25/06/18
Prepared by A.A.	Checked by C.V.C.	Replaced on	

Rev.	Revised sections	Checked	Date

REVISION INDEX OF THE MANUAL AND ITS PARTS

PART OF THE MANUAL	Revision	Date	Revision	Date	Revision	Date
Index	0	20/06/2018	1	05/10/2018		
Chapter 0	0	20/06/2018				
Chapter 1	0	20/06/2018				
Chapter 2	0	20/06/2018				
Chapter 3	0	20/06/2018				
Chapter 4	0	20/06/2018	1	05/10/2018		
Chapter 5	0	20/06/2018	1	05/10/2018		
Chapter 6	0	20/06/2018				
Chapter 7	0	20/06/2018				
Chapter 8	0	20/06/2018				

Date	05/10/2018
Signature	

TABLE OF CONTENTS

REVISION INDEX OF THE MANUAL AND ITS PARTS	1
TABLE OF CONTENTS	2
0 INTRODUCTION	3
1 SCOPE OF THE USE AND MAINTENANCE MANUAL	3
2 HOW TO READ THIS USER MANUAL	3
1 GENERAL INFORMATION	4
1 MANUFACTURER'S IDENTIFICATION DATA	4
2 CE MARKING	5
3 DECLARATIONS	6
4 TECHNICAL SUPPORT - INFORMATION	7
2 SAFETY	8
1 GENERAL SAFETY WARNINGS	8
2 USE RESTRICTIONS	8
3 ELECTROMAGNETIC COMPATIBILITY	8
4 SAFETY	8
5 SAFETY PICTOGRAMS	9
3 INSTALLATION	10
1 TRANSPORT AND HANDLING	10
2 POSITIONING	10
3 ADJUSTMENTS	11
4 ASSEMBLY	11
5 ELECTRICAL CONNECTIONS	12
4 PRODUCT DESCRIPTION	14
1 OPERATING PRINCIPLE	14
2 MAIN COMPONENTS AND DIMENSIONS	15
3 ENVIRONMENTAL CONDITIONS	17
4 TECHNICAL DATA	18
5 USE AND SOFTWARE	19
1 INTERFACE	19
2 ICONS	19
3 MENU	20
6 MAINTENANCE	34
1 ROUTINE MAINTENANCE	34
2 TROUBLESHOOTING	34
7 ACCESSORIES AND SPARE PARTS	35
1 ASSISTANCE	35
2 SPARE PARTS	35
8 ADDITIONAL INSTRUCTIONS	36
1 DECOMMISSIONING AND DISASSEMBLY	36

0 INTRODUCTION

1 SCOPE OF THE USE AND MAINTENANCE MANUAL

This manual provides the user with general guidelines to use the product safely.

This User Manual is an integral part of the product and provides the following information about the product:

- technical specifications;
- a description of its operation and limits;
- instructions on how to use it under safe conditions;
- instructions on how to perform maintenance and repairs correctly and safely;
- technical support;
- instructions on waste disposal.

2 HOW TO READ THIS USER MANUAL

This manual is divided into chapters. Each one of them provides specific information.

NUMBERING OF THE FIGURES

Each figure is numbered progressively.

Each figure is numbered progressively.

NUMBERING OF THE TABLES

Each table is numbered progressively.

The progressive number starts from 1 at every new paragraph.

ABBREVIATIONS

Cap. = Chapter

Par. = Paragraph

Sec. = Section

Page = Page

Fig. = Figure

Tab. = Table



1 GENERAL INFORMATION

1 MANUFACTURER'S IDENTIFICATION DATA

MANUFACTURER	OBL S.R.L.
REGISTERED HEADQUARTERS AND ADMINISTRATIVE OFFICE	Via Kennedy 12 - 20090 Segrate (MILAN) ITALY
TELEPHONE NUMBER	0039 02 26 91 91
E-MAIL	Obl.info@idexcorp.com

2 CE MARKING

Every product is identified with a CE plate indicating its reference data, which are printed indelibly.

 	
Via Kennedy n°12 - Segrate - MILANO +39 02 26 9191 - obl.info@idexcorp.com	
1	MODEL KIT PRO
2	230 V 50 Hz
3	MAX CURRENT 5 A MAX POWER 1500 W
	MAX MOTOR POWER 750 W
	ENCLOSURE IP65
7	SERIAL No. 2018P4831 06/2018
1=Product model	6=Protection rating
2=Power supply voltage	7=Serial number
3=Maximum current consumption	8=Month and year of manufacture
4=Power supply frequency	9=Max power of the motor
5=Maximum power consumption	

3 DECLARATIONS



EU DECLARATION OF CONFORMITY (UT5604-0)
(ANNEX IV, DIR. 2014/35/EU)
THE MANUFACTURER

COMPANY NAME	OBL SRL
ADDRESS	VIA KENNEDY 12, 20090 Segrate – MILAN - Italy

DECLARES THAT THE PRODUCT

NAME	MODEL
KIT PRO	KIT PRO

COMPLIES WITH THE FOLLOWING EUROPEAN DIRECTIVES

DIRECTIVE 2014/35/EU of the European Parliament and Council, dated 26 February 2014, on the harmonisation of the laws of the Member States relating to the making available on the market of electrical equipment designed for use within certain voltage limits

DIRECTIVE 2014/30/EU of the European Parliament and Council, dated 26 February 2014, on the harmonisation of the laws of the Member States relating to electromagnetic compatibility (recast)



AND THAT THE FOLLOWING STANDARDS HAVE BEEN APPLIED
(PARTS/ARTICLES OF HARMONISED STANDARDS)

EN 61800-5-1	Adjustable speed power drive systems - Part 5-1: Safety provisions - Electric, thermal, and energy safety
---------------------	--

DATE AND PLACE

Segrate, 26/06/18

SIGNATURE

4 TECHNICAL SUPPORT - INFORMATION

This product is guaranteed as stated in the general terms and conditions of sale. Should malfunctions or failures (included within the cases covered by the warranty) be detected during the warranty period, the Manufacturer will repair or replace the defective parts, prior to verification.

2 SAFETY

1 GENERAL SAFETY WARNINGS

The Manufacturer has designed this product to make it as SAFE as possible.

Every OBL KIT PRO is a reliable, quality product, which undergoes careful end inspection to ensure proper operation and ascertain compliance with specified performance.

The Manufacturer of the machine must install the product and comply with all the regulations and safety standards in force in the country of installation.

Attention! When using mains-powered equipment, always follow basic safety precautions, including the following, to reduce damage to people and property:

Carefully read the instructions in this manual before installing/using the device.

Keep these instructions for future use.

2 USE RESTRICTIONS

The PRO KIT can be installed only and exclusively on the following pump models:

1. OBL's metering pumps of the Black Line series (M diaphragm version)
2. OBL's metering pumps of the Black Line series (R piston version)

3 ELECTROMAGNETIC COMPATIBILITY

The user is the only responsible for solving problems related to electromagnetic compatibility once the end product is complete. In some cases, the equipment needs to be earthed correctly, while in others a screen may be required. The manufacturer of the KIT PRO is available to help the user solve problems related to electromagnetic compatibility upon request.

4 SAFETY

- Carefully read this use and maintenance manual before starting, using, performing maintenance, or any other operation on the equipment.

- Strictly comply with the warnings contained in the manual, whether they indicate danger or caution.
- The operator must meet all the requirements for using this type of machine.
- Always wear personal protective equipment in compliance with the occupational safety regulations in force.
- Before proceeding with the installation, make sure that the area does not feature any dangerous condition. Make sure no foreign bodies have been left inside or on the machine.
- Start the machine start-up sequence following the instructions.
- Do not enter the machine's operating area while the machine is running.
- Do not introduce your hands or anything else near or inside the equipment live parts.
- Do not work in dark conditions. Use all the lights available, making sure they are efficient.
- Do not use the machine when under the influence of medicines or alcohol, as they may impact your capacity of moving and thinking.
- Stay concentrated and use caution before carrying out any operation.
- Always keep the work area clean.
- Warn the maintenance managers about any malfunction of parts or systems on board the machine.
- Do not wear loose clothing, but always accident-prevention clothing.

5 SAFETY PICTOGRAMS

The device is installed on OBL metering pumps. Pay attention to the safety pictograms on the pumps.

3 INSTALLATION

1 TRANSPORT AND HANDLING

The KIT PRO can be handled manually as it weighs only 5 kg. Always transport the product inside its original packaging.

2 POSITIONING

The Black Line 2.0 M and R pumps can be installed on a KIT-PRO, as shown in Figure 1.

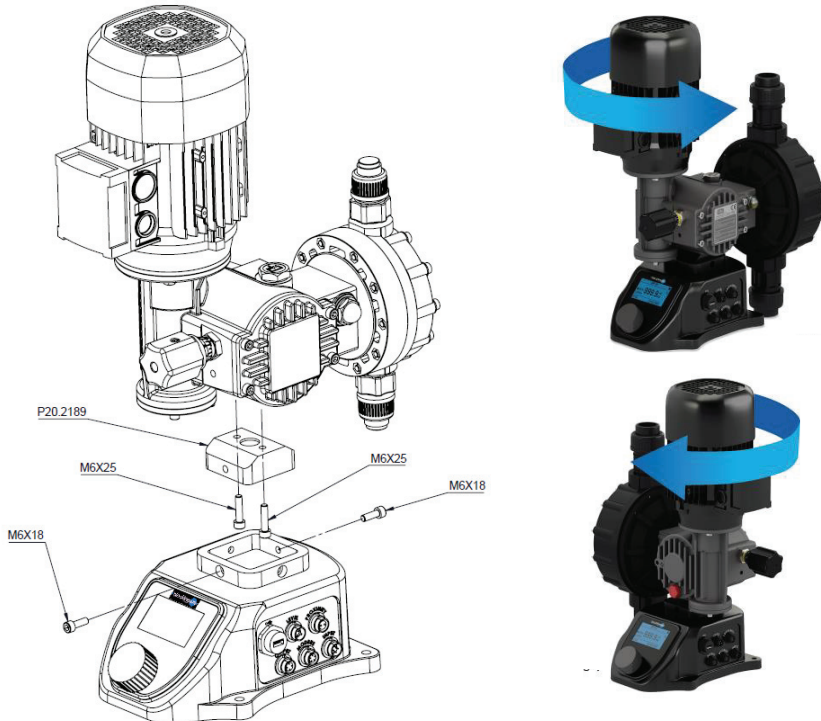

Figure 1 Installation of the KIT

Moreover, the orientation of the KIT PRO can be changed from 0 to 90° compared to the pump. To carry out this operation, you just have to:

1. unscrew the 2 screws (M6x18)
2. rotate the pump
3. tighten the 2 screws (M6x18)

3 ADJUSTMENTS

See chapter 5 "USE AND SOFTWARE"

4 ASSEMBLY

The KIT PRO can be supplied in two versions:

- Assembled on an OBL metering pump (Black Line series)
- The assembly kit can be assembled and installed on an OBL Black Line 2.0 metering pump (manufactured from May 2017 onwards)

The KIT PRO must be assembled on pumps not installed in a system. **Contact an OBL distributor in the event the OBL pump on which the KIT PRO is to be installed is already operating in a system.**

The KIT PRO is suitable for all OBL metering pumps of the Black Line series with a standard motor (three-phase power supply 380V/230V 50 Hz). Contact an OBL distributor in the event motors with different characteristics are installed.

Follow the instructions below to assemble the KIT PRO on OBL's Black Line metering pumps:

1. Make sure the motor is not powered
2. Make sure that the OBL metering pump on which the KIT PRO is to be installed is not running.
3. Disassemble the base of the Black Line pump (pos. 117 in the BL2.0 M and R section drawings)
4. Mount connection P20.2189 (Figure 1) using the M6x25 screws.
5. Fasten the KIT PRO to the connection (Figure 1) using the provided M6x18 screws.
6. Disconnect any connection to the electric motor terminal box of the Black Line metering pump.
7. Connect the KIT PRO's output cable to the terminal box of the Black Line pump's motor, making sure that the connection is delta (230 V). Refer to the use and maintenance manual of the Black Line metering pump, chapter 2 paragraph 6, and chapter 8.
8. When the KIT PRO is to be installed in a system, it must be fixed to a stable support by tightening the M8 screws into the Ø8.5 holes on the body (Figure 2).

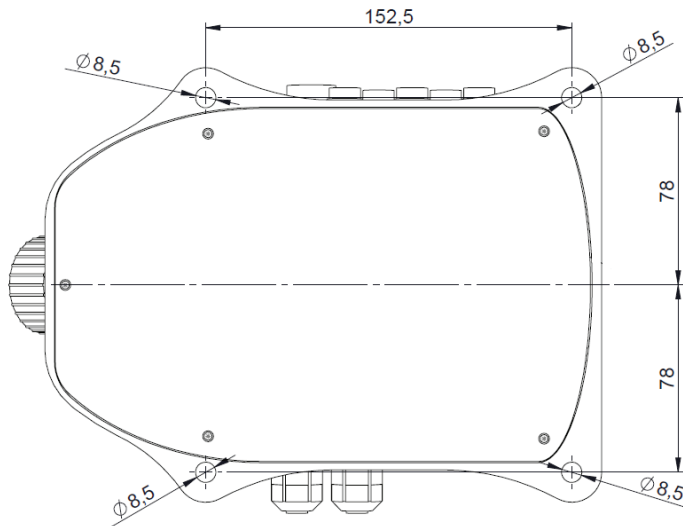

Figure 2 Fastening holes

9. **Before making electrical connections, make sure that the power mains voltage matches the information contained on the KIT PRO data plate.**

5 ELECTRICAL CONNECTIONS

5.1 Power supply connection

The cable glands should be tightened so that seal rings keep the necessary pressure:

- to prevent transmission of mechanical stress on the motor terminals
- to ensure mechanical protection (IP degree) of the terminal box

⊥ NOTE: Always make the earth connection using the appropriate earth wire on the main power cable.

NOTE: In the event of power outage or disconnection, let the screen switch off before reconnecting the power supply.

5.2 Signal connection

The KIT PRO has different signal connections, whose name are shown on the enclosure.

The KIT includes the relative connectors, which are provided with a 1-metre cable. The cables supplied feature 4 conductors featuring different colours (yellow, green, brown, and white).

Table 1 shows the connectors needed.

Table 1 Connectors

CONNECTOR	PIN FUNCTION	CONDUCTOR COLOUR
INPUT	Remote Start/Stop	Yellow
	Pulses	Green
	Earth (-)	Brown
	4-20 mA/0-10V analogue	White
MODBUS	A	Yellow
	B	Green
	Earth (-)	Brown
OUPUT	4-20 mA analog (+)	Yellow
	Relays	Green
	4-20 mA analog (-)	Brown
	Relays	White
LEVEL	Start	Green
	Stop	Yellow
	Earth	Brown
USB 2.0 HOST	Suitable for the connection of a USB flash drive	
Proximity	Suitable for the connection of the supplied proximity sensor.	

5.3 Connecting the stroke counter sensor (proximity)

The stroke counter sensor Figure 7 is provided with the KIT PRO.

To install it, you just have to:

1. Loosen the oil cap (pos. 119 of the section drawing)
2. Tighten the proximity sensor in the oil cap housing
3. Connect the proximity sensor to the electronics using the appropriate connector

The proximity sensor is supplied with a spacer. Use the spacer on the M version of the KIT PRO and remove it from the R version.

NOTE: Always make the connection using the appropriate connector. Do not use or connect other inductive sensors to the proximity connection. Make all the connections only when the pump is at a standstill.

4 PRODUCT DESCRIPTION

1 OPERATING PRINCIPLE

The KIT PRO is a management and control system for OBL's Black Line metering pumps. The KIT PRO can adjust the flow rate, changing the number of revs of the pump's electric motor. The KIT PRO has different operating modes (cf. chapter 5) to manage the pump's flow rate.

The KIT PRO can receive an input alarm signal from the instruments installed on the metering system, such as the level sensors.

The KIT PRO is provided with a display from where you can see the pump's operating status and enter the flow rate parameters. The different operating statuses of the pumps have different colours:

- Operating mode colour (green, blue, azure, lilac): correct operation
- Yellow: incorrect yet not dangerous operation
- Red: incorrect operation and pump lock

The PRO KIT does not adjust the stroke of the metering pump (cf. Use and maintenance manual of the Line Black pump, chap. 10.2).

The KIT PRO adjusts the ratio between maximum and minimum flow rate provided, as it adds the possibility to vary the number of revs of the electric motor and adjust the pump's stroke. This way, the turndown ratio can be of 500:1.

NOTE: The system does not automatically record every adjustment. Therefore, the flow rate and volume indicated by the software may differ from those actually provided, unless a calibration procedure is carried out (Table 6) with the new adjustment position.

2 MAIN COMPONENTS AND DIMENSIONS

As shown in the following figures, the KIT PRO consists of:

1. 1 enclosure containing the electronic control unit
2. 1 connection
3. 1 proximity sensor
4. 4 connectors with a 1-meter cable

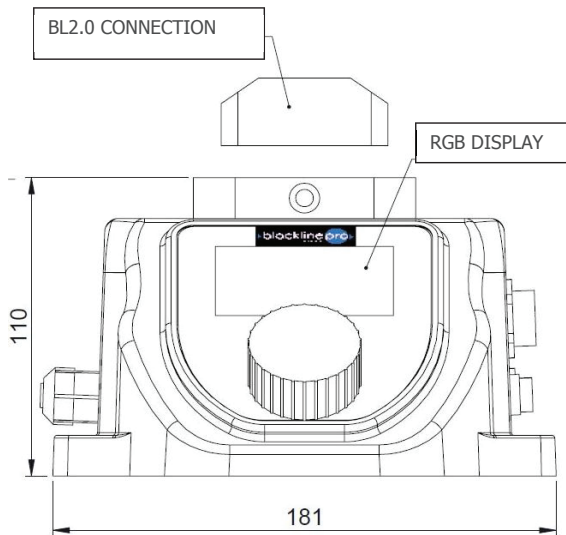

Figure 3 Front view

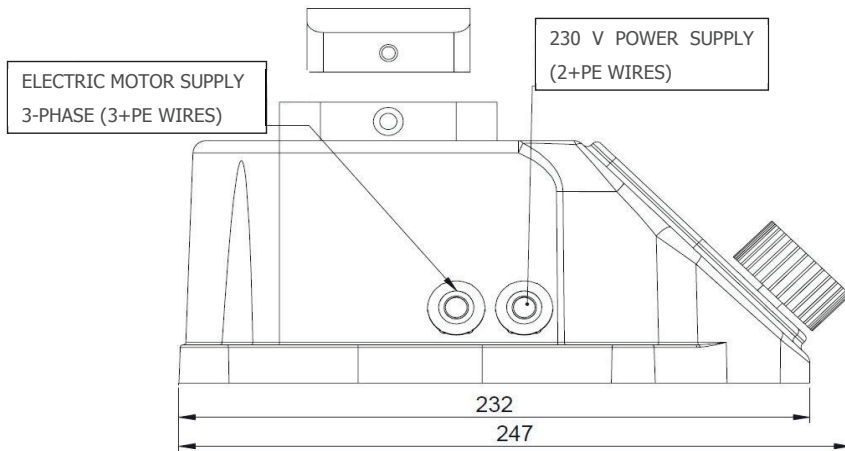

Figure 4 Side view of the supply lines

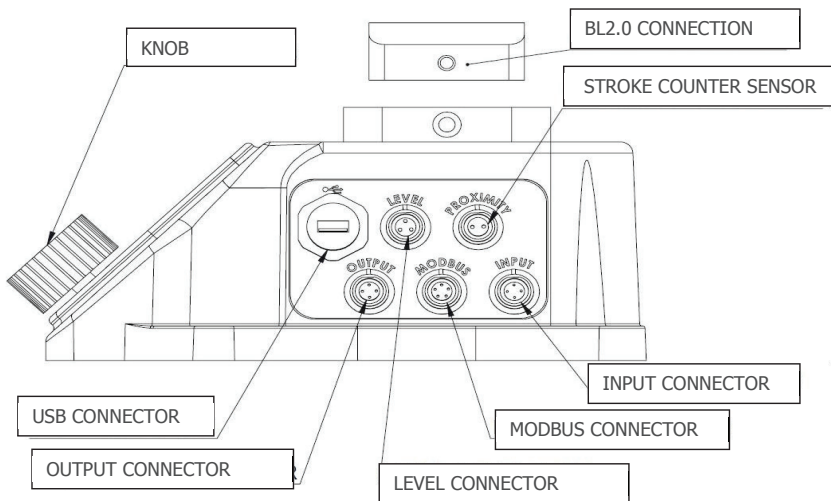

Figure 5 Side view of the supply lines

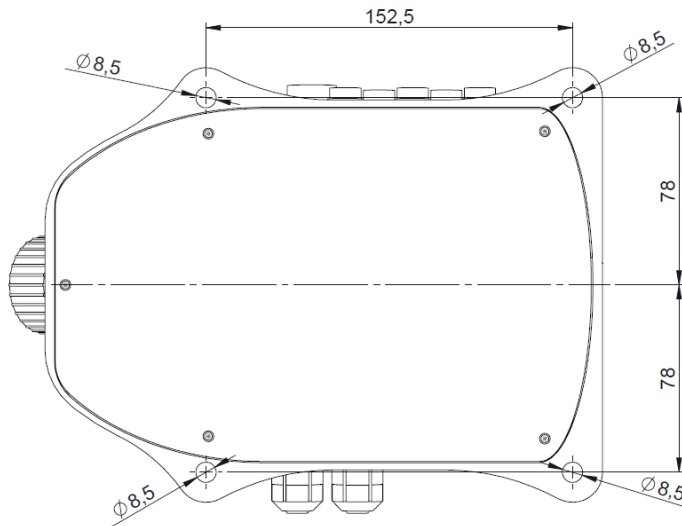

Figure 6 – Layout

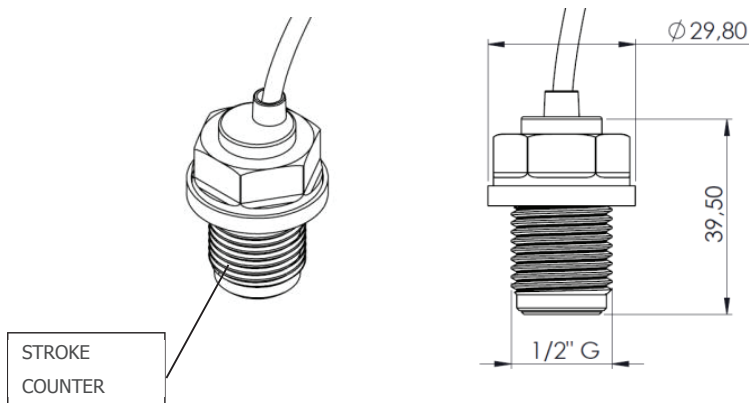

Figure 7 stroke counter sensor

3 ENVIRONMENTAL CONDITIONS

As for installation, the environmental conditions must match the possible use conditions of OBL's metering pumps, which can be combined with the KIT PRO.

4 TECHNICAL DATA

The KIT PRO is suitable for all OBL's metering pumps of the Black Line series with a standard motor (three-phase power supply 230/380V 50 Hz). Contact an OBL distributor in the event motors with different characteristics are installed.

Table 2- Technical data

		M	R	
Mechanical data	Max. flow rate (@ 1.5 bar)	800 l/hr	300 l/hr	
	Max pressure	12 bar	40 bar	
	Max. stroke frequency	155 strokes/min	114 strokes/min	
	Max. suction lift	1.5 m	1.5 m	
	Liquid temperature	-10°C - +40°C	-10° - +90°C	
	Max. weight	28 Kg	26 Kg	
	Accuracy	+/-3%		
	Linearity	+/-5%	+/-3%	
	Repeatability	+/-3%		
	Turndown ratio	500:1		
	Sound pressure	<65 dbA		
	Materials (actuator, casing, motor)	Aluminium		
	Finishing (actuator, casing)	Electrophoretic deposition (EPD)		
	Electrical data	Max power consumption	1500W	
Max motor power		750W		
Max output current		3,3 A on 1,9 A off (0,2 s ON 50%) 3A (100%)		
Max input current		4.2 A		
Power Supply		110 V AC 240 V AC		
Frequency		50/60 Hz		
Operating temperature		-10/40 °C 14/113 °F		
Max inrush current		2,3A (110V) 5A (230 V)		
Enclosure class (actuator only)		IP65		
Recommended fuse		6.3 x 32 mm 8A		
USB	Type	USB 2.0 HOST		
Serial	MODBUS RTU	Half Duplex RS-485		
Input	4-20 mA	Input Voltage /Control input passive	14 V DC	
		Impedance	120 Ω	
	0-10 V	Input Voltage /Control input passive	10 V DC	
		Impedance	120 Ω	
	Pulse	Max load	28 V DC	
		Max resistance in pulse circuit	15 KΩ	
		Min pulse length	10 ms	
	Remote	Max load START/STOP digital input	28 V DC	
Level	Max load STOP digital input	28 V DC		

Output		Max load START digital input	28 V DC
	4-20 mA	Input Voltage /Control input passive	48 V DC
	Relays	Max load	24 V DC 3A

5 USE AND SOFTWARE

1 INTERFACE

The user interface consists of an encoder with a knob, which allows you to carry out two operations:











Table 3 Interface



ROTATION	Turn the knob to move a selector switch to the required item. Moreover, you can increase or decrease the value of a selected item.
CLICK	Press the knob to confirm a selected value or access different items of the menu.

2 ICONS

The icons used in the program and relative function are summarised in the following table:

Table 4 Icons

ICON	FUNCTION
	Main Menu
	Statistics
	Settings
	Previous page
	Off
	Start
	Stop
	Alarm
	Manual adjustment value
	Operating frequency
	Flow partialisation

	Reset
	Modbus

3 MENU

3.1 Home page



Figure 8 Home page

3.2 Operating modes

From the home page, click "operating modes" to select the operating mode you need. Each mode features an input screen (Figure 9) and an operating screen (Figure 10).

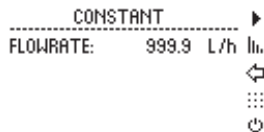

Figure 9 Input



Figure 10 Operating screen

You can change the mode operating parameters or carry out operations by using the icons on the right side of every input screen:

1. Start: to start the set mode
2. Statistics (Figure 11): you can view:
 - a. The volume provided and the partial resettable activation time (by clicking on the reset icon)
 - b. The volume provided and the total non-resettable activation time

```

-----
          STATS
-----
PARTIAL VOL.  900.00 L  ⌘
PARTIAL LIFE  00d00h00m  ⏪
TOTAL VOL.    600.00 L  ⋮
TOTAL LIFE    00d00h00m  ⏩

```

Figure 11 Statistics

3. Back: to return to the previous menu
4. Settings: to open the setting menu
5. Off: to set the electronics in standby.

The operating modes available are shown in the following table:

Table 5 Operating modes

Modes	Input parameters	Description
Constant	FLOW RATE	The pump runs at a constant flow rate
Batch	VOLUME FLOW RATE START (MANUAL OR EXTERNAL)	The pump doses the volume of liquid at the set flow rate. Upon manual start, the process is repeated once and then it stops. Upon external start, the pump waits for the signal to start based on the set parameters and waits for a signal to repeat the process again.
PPM	PPM CONCENTRATION PULSE/L (L/PULSE) TIMEOUT	When the pump receives an external input signal sending pulses, it doses the liquid based on the liquid concentration value and ppm required at destination. The PULSE/L and L/PULSE parameters allow you to set the characteristics of the meter. The TIMEOUT parameter considers the maximum interval between two subsequent pulses.
Percentage	PERCENTAGE CONCENTRATION PULSE/L (L/PULSE) TIMEOUT	When the pump receives an external input signal sending pulses, it doses the liquid based on the concentration value of the liquid and the concentration required at destination (Percentage). The PULSE/L and L/PULSE parameters allow you to set the characteristics of the meter. The TIMEOUT parameter considers the maximum interval between two subsequent pulses.

MLQ	MLQ CONCENTRATION PULSE/L (L/PULSE) TIMEOUT	When the pump receives an external input signal sending pulses, it doses the liquid based on the concentration value of the liquid and millimetres per quintal (MLQ) required at destination. The PULSE/L and L/PULSE parameters allow you to set the characteristics of the meter. The TIMEOUT parameter considers the maximum interval between two subsequent pulses.
Pulse	MAXIMUM PULSE VALUE/M MINIMUM PULSE VALUE/M MAXIMUM FLOW RATE MINIMUM FLOW RATE TIMEOUT	When the pump receives a pulse input signal, it adjusts the flow rate based on the value of pulses per minute received between the maximum and minimum values. The TIMEOUT parameter considers the maximum interval between two subsequent pulses.
Analog mA	MA MAXIMUM VALUE (20 MA) MA MINIMUM VALUE (4 MA) MAXIMUM FLOW RATE MINIMUM FLOW RATE	The pump adjusts the flow rate based on an external analog signal and the maximum and minimum values set in the inputs.
Analog V	MAXIMUM V VALUE (10 V) MINIMUM V VALUE (0 V) MAXIMUM FLOW RATE MINIMUM FLOW RATE	The pump adjusts the flow rate based on an external analog signal and the maximum and minimum values set in the inputs.
Pause-work	FLOW RATE OPERATING PERIOD (MIN) PAUSE PERIOD (MIN)	The pump alternates pause periods with constant flow rate operation periods whose duration can be set.
Weekly	SET A PROGRAM: <ul style="list-style-type: none"> • PROGRAM No. • DURATION • START TIME • CONSTANT FLOW RATE • VOLUME • DAYS OF ACTIVITY 	This menu allows you to set the data of each program (max 13 programs). You can set the constant flow rate or volume of constant flow rate to be transferred, transfer duration, start time, and days of activity. We recommend not overlapping the programs.
	ACTIVE PROGRAMS	This menu shows the active programs and allows you to activate or deactivate them.

3.3 Partialisation

In the event that the required flow rate is 30% lower than the set flow rate during calibration, the pump starts the partialisation stage. This stage consists in:

1. Work stage, in which the pump runs at 30%
2. Pause stage

The duration of these two stages are calculated by the firmware so as to obtain the flow rate required.

The minimum flow rate provided is 1% the maximum flow rate. The pump fails to start if this value is not reached.

3.4 Settings

The setting menu is shown in Figure 12 and allows you to open all the functions described in Table 6.

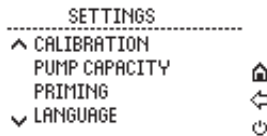

Figure 12 Settings

Table 6 Settings

Modes	Input parameters	Description
Calibration	TEST DURATION MAXIMUM MOTOR PHASE CURRENT MOTOR FREQUENCY	This mode allows you to test the pump's flow rate at the maximum frequency. The pump capacity screen appears at the end of the test. Moreover, you can set the test pressure (for test purposes only). Moreover, you can set the motor phase current so that the system can block the pump once this current value is exceeded (§Table 7 motor short-circuit alarm). The system saves the date of the last test performed. NOTE: it is good practice to calibrate the pump every time process conditions change (pressure, manual adjustment value, etc.).
Pump capacity	MAXIMUM FLOW RATE	In this screen, you can enter the flow

	TEST VOLUME ADJUSTMENT TEST PRESSURE DATE OF THE LAST TEST PERFORMED	rate or volume obtained during calibration. The maximum flow rate set will never be exceeded in the operating modes. The adjustment value is displayed in the operating screen.
Priming	PRIMING TIME	Set the priming time and click start to start the priming function. Press stop to stop the priming function.
Languages	IT EN ES FR NL RU DE TU	Select language
Password	USER ADMIN	Set the 4-digit password for each user (it blocks the parameter setting of the operating modes) or administrator (it blocks the access to settings).
DATE & CLOCK	DATE FORMAT (DD/MM/YY) TIME FORMAT (24/12 H) DATE TIME	You can choose how you want to display the date and time. These data are added to the statistics report.
UNIT OF MEASUREMENT	Flow Rate L/h and Gal/h.	Even the volume measurement units are updated accordingly.
PROXIMITY	Alarm activation with red display.	The proximity sensor (supplied) verifies the correct operation of the pump. The firmware stops the pump if the number of strokes is equal to 0 with active pump. An error is recorded in the report. The error can be reset in the alarm log.
FIRMWARE INFO	INFO UPDATE FIRMWARE EXPORT PARAMETERS IMPORT PARAMETERS EXPORT LOG DELETE LOG RESTORE TO FACTORY SETTINGS	This screen allows you to interface with the USB port, through which you can update the software, import and export parameters, export and delete reports, check the software version, and restore the default settings of the system. Export the report before updating the software so as not to erase the log file from the system.
MODBUS	MODBUS (YES/NO)	This setting allows you to control the

	BAUD RATE ADDRESS	pump in Modbus.
ANALOG OUTPUT	OUTPUT	Possibility to activate the output of a proportional analog signal at the operating frequency.
RELAY	OUTPUT (OFF / START/STOP / ALARM) CONTACT (N.O. /N.C.)	This function allows you to use the relay with a N.O. or N.C. contact. The output signal indicates the pump's status (ON/OFF) or the presence of an alarm.
DISPLAY	MENU' LIGHT (ON/OFF) WORKING COLOUR (GREEN, PINK, BLUE, AZURE) CONTRAST (0-100%)	Display settings: backlight activation while browsing the menus, colour selection in operating modes, contrast.
LEVEL	STOP (YES/NO) CONTACT (N.O./N.C.) RED ALARM DISPLAY (YES/NO) START (YES/NO) CONTACT (N.O./N.C.)	Setting for starting or stopping the pump remotely (usually from a level sensor). You can also decide whether to activate the red display with the pump at a standstill. This setting uses the two pins on the level connector.
REMOTE START/STOP	START/STOP (YES/NO) CONTACT (N.O./N.C.)	Setting for starting or stopping the pump remotely. One single pin is used in this case. The pump starts when the contact is closed and blocks when the contact is open (or vice-versa, depending on the N.O. or N.C. contact).
OVERFLOW	ALARM (YES/NO) LIGHT ALARM (YES/NO) STOP OR WORK	In PPM, MLQ, and Percentage modes, you can activate an alarm (overflow) to block (STOP) or run (WORK) the pump if the flow rate calculation exceeds the flow rate set during the calibration stage.

3.5 Alarm log

The alarm log contains all the triggered alarms. Select the reset icon to reset an alarm.

ALARM REGISTER

PR014 - 24/05/18 - 18:20



The alarms are summarised in Table 7.

Table 7 Alarms

ALARM CODE	ALARM TYPE	DESCRIPTION	CAUSE	VISUAL FEEDBACK (SCREEN)
TOU01	ELECTRONICS HARDWARE	TIMEOUT	Failed communication between two microcontrollers	FLASHING RED
CUR02	ELECTRONICS HARDWARE	OVER CURRENT	The motor current exceeds the limit	
TEM03	ELECTRONICS HARDWARE	OVER TEMPERATURE	The temperature exceeds the board limits.	
OVB04	ELECTRONICS HARDWARE	OVER BUS	Voltage exceeds the sheet limits	
INR05	ELECTRONICS HARDWARE	INRUSH	Inrush relays broken	
TRI06	MOTOR HARDWARE	TRIP	Motor short circuit	
PRO07	FUNCTIONAL	PROXIMITY	Motor or Pump block	FLASHING YELLOW
DFL08	FIRMWARE	DATA FLASH	Data setting error	
EFL09	FIRMWARE	EXT FLASH	Log write error and FW update error	
RTC10	ELECTRONICS HARDWARE	RTC	Clock error upon power-on (the clock is set to a non-admitted time). Flat battery.	
LOG11	FIRMWARE	LOG	Error in recording the file log	FIXED RED
LVL12	PROCESS	LEVEL	STOP input of the level sensor	
OVR13	PROCESS	OVERFLOW	Overflow alarm	FIXED RED OR FIXED YELLOW
RMT14	PROCESS	REMOTE STOP	Alarm resulting from	FIXED RED

			remote stop	
AMA15	PROCESS	ANALOG mA	Input current beyond the range set in the analog mA mode.	FIXED RED
AVA16	PROCESS	ANALOG V	Input voltage beyond the range set in the analog V mode.	FIXED RED
UVG17 UVB18	ELECTRONICS HARDWARE		Power supply voltage too low.	

3.6 Modbus

Table 8 Modbus Specification

MODBUS SPECIFICATION	
Serial interface	RS 485 half duplex
Protocol	MODBUS-RTU
Baud rate	2400-4800-9600-19200-38400-57600-115200 bps
Start bit	1
Data length	8 bit
Parity bit	N. A.
Stop bit	1
Cyclic Redundancy Check (CRC)	CRC-16
ID slave address	1 to 247
Modbus parameters registers	Da 40001 a 40058
Modbus commands registers	Da 41001 a 41016
Registers that can be read with 1 command	58
Registers that can be written with 1 command	58
Function Codes	03 (03 hex) – read holding register 16 (10 hex) – preset multiple holding register
Exclusion Codes	01 (01 hex) – illegal function 02 (02 hex) – illegal data value 03 (03 hex) – illegal data address 07 (07 hex) – NAK

The user can activate MODBUS functionality in settings menu.

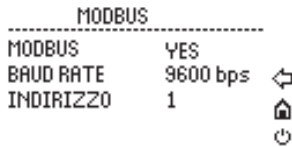

Figure 13 Modbus settings

In MODBUS window, the user can:

1. activate MODBUS (YES/NO)
2. set the baud rate (2400-4800-9600-19200-38400-57600-115200 bps).
3. set the slave device address

When MODBUS is active, the user can locally do the following operations:

1. When the motor is ON
 - a. To stop the pump (selecting STOP icon)
 - b. To display statistics
2. When the motor is OFF:
 - a. To navigate in the menu
 - b. It is not possible to start up the motor. The user has to turn off MODBUS mode to start up the motor.

When MODBUS is active, an icon will appear on the right corner of all windows of the firmware.

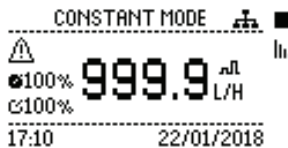

Figure 14 Modbus operating mode

COMMUNICATION EXAMPLE

Black Line PRO can communicate with a PLC using MODBUS interface.

Examples of communications are described hereinafter:

1. Read Holding Registers (Function Code 03)
 - a. Request:

This command is requesting the content of holding registers 40024 to 40025 from the slave device with address 01.

```
01 03 0017 0002 740F
```

01: Slave Address (01 hex)

03: Function Code (Read holding registers)

0017: The Data Address of the first register requested. (40024 - 40001 = 17 hex)

0002: The total number of registers requested. (read 2 registers 40024 to 40025)

740F: CRC (cyclic redundancy check) for error checking.
 - b. Response:

```
01 03 04 003C 003C 3A2E
```

01: Slave Address (01 hex)

- 03: Function Code (Read holding registers)
- 04: The number of data bytes to follow (2 registers x 2 bytes each = 4 bytes)
- 003C: The contents of register 40024
- 003C: The contents of register 40025
- 3A2E: The CRC (cyclic redundancy check).

2. Preset Multiple Registers (FC=16)

a. Request

This command is writing the contents of two holding registers 41003 and 41004 to the slave device with address 01.

01 10 03EA 0002 04 0000 0000 6968

- 01: The Slave Address (01 hex)
- 10: The Function Code (Preset Multiple Registers)
- 03EA: The Data Address of the first register. (41003 - 40001 = 03EA hex)
- 0002: The number of registers to write
- 04: The number of data bytes to follow (2 registers x 2 bytes each = 4 bytes)
- 0000: The value to write to register 41003
- 0000: The value to write to register 41004
- 6968: The CRC (cyclic redundancy check) for error checking.

b. Response

- 01 10 03EA 0002 6078

- 01: The Slave Address (01 hex)
- 10: The Function Code (Preset Multiple Registers)
- 03EA: The Data Address of the first register. (41003 - 40001 = 03EA hex)
- 0002: The number of registers written.
- 6078: The CRC (cyclic redundancy check) for error checking.

3. Read Holding Registers (FC=03) ERROR

a. Request

- This command is requesting the content of analog output holding registers 40100 (register out of range) from the slave device with address

- 01 03 9CA3 0001 5A78

b. Response

- 01 83 02 C0F1

- 01: The Slave Address (01 hex)
- 83: The Function Code (Preset Multiple Registers) with 1 to MSB error code (illegal data address)
- 02: error code (illegal data address)
- C0F1: The CRC (cyclic redundancy check) for error checking.

MODBUS LIST

The list of the registers and parameters that the user can write/read using Modbus is described in the following table:

Table 9 Modbus list

Nr. Reg.	PAR.	TYPE MOTOR OFF	TYPE MOTOR ON	BYTE	Min value	Max value	Default	U.M.	Description
40001	M_TIME_S	W/R	R	2	1	120	60	s	Calibration time - calibration settings
40002	M_FLOW	W/R	R	2	1	9999	600	(L/h or Gal/h)*10	Max flowrate - pump capacity settings
40003	M_PERC	W/R	R	2	1	100	50	%	Adjustment % - pump capacity settings
40004	M_L_PULSE	W/R	R	2	1	2000	200	L/p or p/L	L/pulse o pulse/L
40005		W/R	R	2	0	5	1		Languages Value 0= Italian Value 1=English Value 2=Spanish Value 3=Dutch Value 4=Russian Value 5=French
40006	M_FDATE	W/R	R	2	0	2	0		Date Format Value 0=DD/MM/YY Value 1=MM/DD/YY Value 2=YY/MM/DD
40007	M_24H	W/R	R	2	0	1	0		Time Format Value 0=24h Value 1=12 h
40008	M_UNIT_LH	W/R	R	2	0	1	0		Unit of measure Value 0=L/h Value 1=Gal/h
40009	M_YES_NO	W/R	R	2	0	1	1		Proximity red alarm Value 0=No Value 1=Yes
40010	M_YES_NO	R	R	2	0	1	0		MODBUS activation Value 0=No Value 1=Yes
40011	M_YES_NO	W/R	R	2	0	1	1		Analog output Value 0=No Value 1=Yes
40012	M_RELAY	W/R	R	2	0	1	1		Relay output activation Value 0=Off Value 1=START/STOP Value 2=Alarm
40013	M_COLOR	W/R	R	2	1	5	2		Display color Value 1=Display OFF Value 2=Green Value 3=Pink Value 4=Light blue Value 5=Blue

40014	M_PERC	W/R	R	2	0	100	50	%	Display contrast
40015	M_YES_NO	W/R	R	2	0	1	0		Red alarm display level and remote control Value 0=No Value 1=Yes
40016	M_YES_NO	W/R	R	2	0	1	0		Red alarm display overflow Value 0=No Value 1=Yes
40017	M_YES_NO	W/R	R	2	0	1	0		START/STOP remote control alarm Value 0=No Value 1=Yes
40018	M_CONTACT	W/R	R	2	0	1	0		Remote control contact Value 0=NO Value 1=NC
40019	M_YES_NO	W/R	R	2	0	1	0		Red alarm display overflow Value 0=No Value 1=Yes
40020	M_STOP_WORK	W/R	R	2	0	1	0		STOP/WORK overflow settings Value 0=STOP Value 1=WORK
40021	M_FLOW	W/R	R	2	1	9999	600	(L/h o Gal/h)*10	Flowrate constant mode
40022	M_VOLUME_INT	W/R	R	2	1	65535	1000	L o Gal	Volume batch mode
40023	M_FLOW	W/R	R	2	1	9999	600	(L/h o Gal/h)*10	Flowrate batch mode
40024	M_MINUTE	W/R	R	2	1	255	60	min	Working time pause-work mode
40025	M_MINUTE	W/R	R	2	1	255	60	min	Pausetime pause-work mode
40026	DIP_MIN	W/R	R	2	5	20	20	mA	High value current 4-20 mA analog mA
40027	DIP_MAX	W/R	R	2	4	20	4	mA	Low value current 4-20 mA analog mA
40028	DIP_MIN M_FLOW	W/R	R	2	1	9999	600	(L/h o Gal/h)*10	Max flowrate analog mA mode
40029	DIP_MAX M_FLOW	W/R	R	2	0	9999	0	(L/h o Gal/h)*10	Min flowrate analog mA mode
40030	DIP_MIN	W/R	R	2	1	10	10	V	High value voltage 0-10 V analog V mode
40031	DIP_MAX	W/R	R	2	0	10	0	V	Low value voltage 0-10 V analog V mode
40032	DIP_MIN M_FLOW	W/R	R	2	1	9999	600	(L/h o Gal/h)*10	Max flowrate analog V mode
40033	DIP_MAX M_FLOW	W/R	R	2	0	9999	0	(L/h o Gal/h)*10	Min flowrate analog V mode
40034	M_U16	W/R	R	2	1	65535	100	PPM	PPM desired in the tank PPM mode

40035	M_PERC	W/R	R	2	1	100	100	%	Concentration dosed fluid PPM mode
40036	M_PERC	W/R	R	2	1	100	100	%	Concentration in the tank percentage mode
40037	M_PERC	W/R	R	2	1	100	100	%	Concentration dosed fluid percentage mode
40038	M_U16	W/R	R	2	1	1000	100	MLQ	MLQ desired in the tank MLQ mode
40039	M_PERC	W/R	R	2	1	100	100	%	Concentration dosed fluid MLQ mode
40040	DIP_MIN M_P_M	W/R	R	2	2	1000	2	p/m	High value pules p/m pulse mode
40041	DIP_MAX M_P_M	W/R	R	2	1	1000	1	p/m	Low value pules p/m pulse mode
40042	DIP_MIN M_FLOW	W/R	R	2	1	9999	600	(L/h o Gal/h)*10	Max flowrate pulse mode
40043	DIP_MAX M_FLOW	W/R	R	2	0	9999	0	(L/h o Gal/h)*10	Min flowrate pulse mode
40044	M_PRESSURE	W/R	R	2	1	300	1	Bar	Calibration pressure – calibration window
40045	M_TYPE_START	W/R	R	2	0	1	0		Batch start Value 0=manual Value 1=external
40046	M_FLOW	W/R	R	2	1	9999	600	(L/h o Gal/h)*10	Flowrate pause work mode
40047	M_CONTACT	W/R	R	2	0	1	0		Contact output relay Value 0=NO Value 1=NC
40048	M_YES_NO	W/R	R	2	0	1	0		Level START contact activation Value 0=No Value 1=Yes
40049	M_YES_NO	W/R	R	2	0	1	0		Level STOP contact activation Value 0=No Value 1=Yes
40050	M_CONTACT	W/R	R	2	0	1	0		Level START contact Value 0=NO Value 1=NC
40051	M_CONTACT	W/R	R	2	0	1	0		Level STOP contact Value 0=NO Value 1=NC
40052	M_YES_NO	W/R	R	2	0	1	1		Menu light Value 0=No Value 1=Si
40053	M_BAUD	R	R	2	0	6	0		Baudrate MODBUS Value 0=2400 Value 1=4800 Value 2=Verde Value 3=Rosa

									Value 4=Azzurro Value 5=Blu
40054	M_TIME_S	W/R	R	2	1	120	120	s	Pulses time out in pulse mode, PPM mode, concentration mode e MLQ mode
40055	M_AMPERE	W/R	R	2	10	35	20		Motor current calibration window
40056	M_50_60Hz	W/R	R	2	0	1	0		50/60 Hz
40057	M_LP_PL	W/R	R	2	0	1	0		L/pulse pulse/L in PPM, MLQ e percentage modes
40058	M_U8	R	R	2	1	247	1		MODBUS ID
41001	OPERATING MODE	W/R	W/R	2	1	10	1	uint16	Operating modes Value 1=Constant Value 2=Batch Value 3=Pause-work Value 4=Weekly Value 5=Analog mA Value 6=Analog V Value 7=PPM Value 8=Percentage Value 9=MLQ Value 10=Pulse
41002	START-STOP	W/R	W/R	2	0	2	0	uint16	Starting motor Value 0=Stop Value 1=Start Value 2=Standby
41003	ALARMS	W/R	W/R	4	This value can be written only to 0			uint3	These registers inform the user about alarms according to the position of the bit
41004									

							BIT 17 "AVA16",,//ANALOG V
41005	PARTIAL LIFE	W/R	W/R	4	This value can be written only to 0	minutes	Durata della vita parziale della pompa. Scrivendo a zero il registro si resetta questo valore nel firmware.
41006							
41007	PARTIAL VOLUME L	W/R	W/R	4	This value can be written only to 0	L*100	Volume parziale in litri erogato dalla pompa. Scrivendo a zero il registro si resetta questo valore nel firmware.
41008							
41009	PARTIAL VOLUME Gal	W/R	W/R	4	This value can be written only to 0	Gal*100	Volume parziale in galloni erogato dalla pompa. Scrivendo a zero il registro si resetta questo valore nel firmware.
41010							
41011	ADJUSTMENT	R	R	2		%	Adjustment
41012	MOTOR	R	R	2		%	Frequency % of the motor
41013	FLOW/VOL.	R	R	4	LSB	float	Flowrate or volume displayed on the screen
41014					MSB		
41015	INFO	R	R	4	LSB	float	Sec, mA, V, flowrate, input, p/m displayed on the screen
41016					MSB		

6 MAINTENANCE

1 ROUTINE MAINTENANCE

Routine maintenance includes operations that are carried out based on the operator's common sense, without following a strict schedule.



HAZARD

Do not carry out routine maintenance operations on mains-powered equipment.

Routine maintenance operations carried out by the user:

- Cleaning



Frequently clean the pump. Dirt and residues must not cover the adjustments or the interface screen.

2 TROUBLESHOOTING

To make a self-diagnosis of the product, see subchapter "Alarm log".

Contact the manufacturer if you detect defects and/or malfunctions that are not described in this manual.

7 ACCESSORIES AND SPARE PARTS

1 ASSISTANCE

Contact the manufacturer for any information relative to installation, use, and maintenance of the product.

For the sake of clarity, the client must always refer to this manual and the instructions listed.

2 SPARE PARTS



**ALWAYS USE ORIGINAL SPARE PARTS.
FOR ANY SPARE PART, CONTACT THE MANUFACTURER.**

The following spare parts are available for the KIT PRO:

Table 10 Spare parts

Spare part kit code	Description	KIT component code	Description
KME60	Connection cables (4 pieces)	KME60	Connection cables (4 pieces)
KPRA08	Proximity sensor	KPRA08	Proximity sensor
KKPRO	Spare part kit for routine maintenance	P20.2189	Pump connection
		KMV150	Knob
		P20.2193	Front label

We do not recommend using non-original spare parts. If you decide to use them, all the Warranty terms and conditions, if still valid, will be void and null and the Manufacturer will not be held responsible for any damage to people and/or property.

8 ADDITIONAL INSTRUCTIONS

1 DECOMMISSIONING AND DISASSEMBLY

It is the user's responsibility to comply with the procedures and regulations in the countries of operation, regarding disposing of waste resulting from maintenance (consumption material) or the demolition of equipment.

"Waste" is intended as any substance or object which the holder has decided to or is required to discard. Waste is classified according to the origin, in "urban waste" and "special waste" and, according to harmfulness, in "hazardous waste" and "non-hazardous waste".



Maintenance or demolition pump waste are classified as "special waste" only if properly cleaned. Otherwise, they are to be considered "HAZARDOUS special waste".



"Special waste" and "urban waste", and especially "hazardous" and "non-hazardous" waste, must never be mixed."

Briefly summarising:

- "special waste" must not be disposed of as "urban waste"
- this waste must be collected separately using public or private collection systems required by local laws (in an approved collection centre)
- due to its use, this equipment may contain hazardous substances. Improper disposal can have adverse effects on human health and the environment.
- administrative sanctions exist in the case of improper disposal of or abuse of waste



Disposal of substances into sewers or abandoning waste in the environment is strictly prohibited. Contact your local waste disposal service to receive adequate and accurate information regarding disposal.

oblblackline.com

OBL S.r.l.

Via Kennedy, 12

20090 Segrate (MI) - Italy

Tel. +39.02.269191

Fax +39.02.2133893

obl.info@idexcorp.com

oblpumps.it

