

# ***Agromatic®***

## **Installation and Operating Manual (Translation of the German Original)**

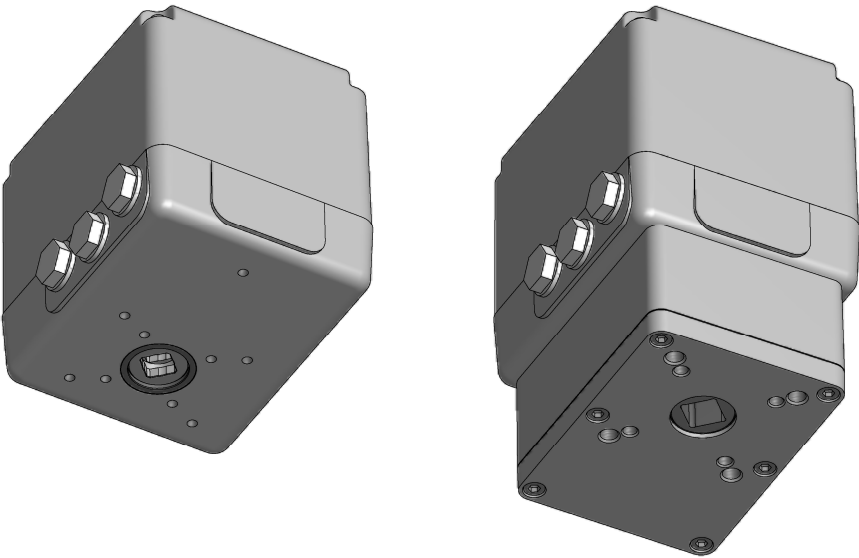

### **Actuator Series NL Position Controller ESR-NL (Option)**

*Keep for future reference!*

## Legal Notice

© Agromatic Regelungstechnik GmbH

This operating manual and all illustrations contained therein are protected by copyright law. Any use of the material outside the restrictions of copyright law without prior written consent from the publisher shall be prohibited and liable to legal prosecution. This shall apply in particular to reproductions, copies, translations, micro-filming, storage and processing with electronic systems.

We reserve the right to make technical changes as a result of improvements to the performance characteristics and further developments without prior written notice.

### Agromatic Regelungstechnik GmbH

Postfach 1162

33804 Oerlinghausen

Germany

Phone: +49 5202 9739-284

Fax: +49 5202 9739-25

E-mail: [vertrieb@agromatic.de](mailto:vertrieb@agromatic.de)

Web: [www.agromatic.de](http://www.agromatic.de)

Revision: 2014-06-30

Document: BA\_NL-ESR-NL\_EN\_rev.01

Order no.: 23137.21



#### **Important information!**

All dimensions in this manual are specified in metric units. The values in millimeter can easily be converted into inches by multiplying the values with the factor 1/25.4.

→ **Note:**

An index is provided on page 87 to help you navigate to specific subjects.

# Contents

<b>1</b>	<b>Introduction .....</b>	<b>1</b>
1.1	Notes and signs used in this document .....	2
1.2	Symbols used in this manual .....	3
1.3	Warranty and liability .....	3
<b>2</b>	<b>Safety .....</b>	<b>5</b>
2.1	General safety instructions .....	5
2.2	Intended use .....	6
2.3	Residual risks .....	6
2.3.1	Hazards from electrical energy .....	7
2.3.2	Danger from moving parts .....	8
2.3.3	Protection classes IP65 (standard), IP66 (option) .....	9
2.4	Personal protective equipment .....	10
2.5	Notes for emergencies .....	11
2.6	Obligations of the owner/lessor .....	12
2.7	Requirements imposed on the personnel .....	13
2.7.1	Responsibilities .....	13
2.7.2	Qualifications required of the personnel .....	14
2.7.3	Obligations of the personnel .....	14
<b>3</b>	<b>Product description .....</b>	<b>15</b>
3.1	Product series .....	15
3.2	Overview .....	15
3.3	Functional description .....	16
3.4	Technical data .....	16
3.4.1	Dimensions .....	16
3.4.2	Weight .....	16
3.4.3	Housing .....	16
3.4.4	Actuator motor .....	17
3.4.5	Functional data .....	17
3.4.6	Airborne noise emission .....	18
3.5	Nameplate .....	19

<b>4</b>	<b>Transportation and storage.....</b>	<b>21</b>
4.1	Acceptance inspection by the receiver.....	21
4.2	Packaging, insulation.....	21
4.3	Transport instructions.....	22
4.4	Interim storage.....	22
<b>5</b>	<b>Assembly.....</b>	<b>23</b>
5.1	General notes.....	24
5.2	Installation.....	26
5.3	Electrical connection.....	29
5.3.1	Determining the direction of rotation.....	31
5.3.2	Schematic diagram for alternating current.....	34
5.3.3	AC schematic diagram with service switch (option).....	35
5.3.4	AC schematic diagram for parallel operation (option).....	35
5.4	Setting the position switches.....	36
5.4.1	Control cam shapes and switches.....	37
5.4.2	Plastic control cam (standard).....	38
5.4.3	Aluminum control cam (option).....	40
5.4.4	Threaded sleeve for a large positioning range (option).....	42
5.5	Connecting and adjusting the potentiometer (option).....	44
5.6	2-wire current output 4 ... 20mA (option).....	46
5.7	Anti-condensate heater (option).....	47
5.8	Installing the hood.....	47
<b>6</b>	<b>Electronic position controller ESR-NL (option).....</b>	<b>49</b>
6.1	Description.....	49
6.2	Electrical connection.....	50
6.2.1	Schematic diagram.....	52
6.2.2	Controls and indicators.....	53
6.2.3	Depiction of the button, switch and LED statuses.....	55
6.2.4	Setting the limit switches and the potentiometer.....	56
6.2.5	Setpoint value input and actual value output.....	57
6.2.6	Programming.....	58
6.2.7	Resetting the controller programming.....	62
6.2.8	LED status indicator.....	63
6.3	Technical data ESR-NL.....	64
<b>7</b>	<b>Operation.....</b>	<b>65</b>
7.1	Auxiliary functions (optional).....	66
7.1.1	Handwheel.....	66
7.1.2	Gearbox decoupling.....	68

---

<b>8</b>	<b>Maintenance and repair</b> .....	<b>71</b>
8.1	Safety instructions .....	71
8.2	Maintenance work .....	73
8.2.1	Maintenance intervals .....	73
8.2.2	Cleaning the actuator .....	74
8.2.3	Leak test .....	75
8.2.4	Visual inspection .....	76
8.2.5	Electrical inspection .....	76
8.3	Spare parts .....	77
<b>9</b>	<b>Malfunctions</b> .....	<b>79</b>
9.1	Safety instructions .....	79
9.2	General notes .....	79
9.3	Repairs .....	80
<b>10</b>	<b>Decommissioning, disassembly</b> .....	<b>81</b>
10.1	Putting the actuator out of operation .....	81
10.2	Dismantling and disposing of the actuator .....	82
<b>11</b>	<b>Appendix</b> .....	<b>83</b>
11.1	Certificates .....	83
<b>12</b>	<b>Index</b> .....	<b>87</b>



# 1 Introduction

This operating manual applies to series NL and in addition to the electronic position controller ESR-NL, which is available as an option to the series NL. The manual provides all the information required for a safe and secure installation and trouble-free operation of the actuator.

This operating manual must be read, understood and applied by all persons responsible for installing, operating, servicing, checking, troubleshooting, dismantling or disposing of the actuator. This shall apply in particular to the safety instructions provided.

After studying the operating manual, you will be able to

- install the actuator in a safe and secure manner,
- operate the actuator in a safe and secure manner,
- service the actuator according to instructions,
- take the appropriate action in case of a malfunction.

Any general, legal or otherwise binding regulations for the prevention of accidents and for the protection of the environment in force in the country of use should be taken into account in addition to the operating manual.

This operating manual is an integral part of the actuator. It should be stored in an easily accessible place close to the actuator during the entire service life of the device.

The following documentation in its current version should also be taken into account:

- the product catalog, and
- the General Terms and Conditions of Agromatic Regelungstechnik GmbH
- any additional operating/installation instructions for optional accessories where applicable (e.g. electronic position controller).

# 1.1 Notes and signs used in this document

Special attention should be paid to text statements in this operating manual serving as notes or direct warning of danger. Such statements are identified as shown below:



## **⚠ DANGER**

### **Warning of dangerous electrical voltage!**

This warning note indicates risks caused by electricity.  
Work on electrical equipment may only be carried out by qualified and authorized electricians.

## **⚠ DANGER**

This warning note identifies an immediate hazard with a high risk, which will lead to death or (serious) personal injury if it is not avoided.

## **⚠ WARNING**

This warning note identifies a possible hazard with a medium risk, which may lead to death or (serious) personal injury if it is not avoided.

## **⚠ CAUTION**

This warning note identifies a hazard with a low risk, which may lead to minor or slight personal injury if it is not avoided.

## **NOTE**

This warning note identifies a hazard with a low risk, which may lead to material damage if it is not avoided.



### **Important information!**

This sign draws attention to a function or setting of the actuator and instructs to exercise caution while working.



Instructions next to this sign must be completed before commencing other activities.

The following means of representation are used in addition:

- Texts following this mark are list items.
- 1. Text next to this mark describes activities to be carried out in the prescribed order.
- “ ” *Text in quotes refers to other chapters, sections or documents.*

## 1.2 Symbols used in this manual

Special dangers are identified by the following symbols in this operating manual:



### **Danger to life due to electric current**

These symbols warn of danger to life due to electrical current. Direct contact with live parts poses an immediate threat to life.



## 1.3 Warranty and liability

The obligations laid down in the supply contract, the General Terms and Conditions, the delivery terms of Agromatic Regelungstechnik GmbH and the legal regulations in force at the time of the signing of the contract shall apply.

All information and instructions in this operating manual were composed in due consideration of the standards and regulations in force, state-of-the-art technology as well as long-term knowledge and experience.

Each actuator will be subjected to tests before it leaves the factory. However, the actuator should be subjected to final functional testing by qualified technical staff after installation.

Agromatic Regelungstechnik GmbH shall not accept any liability for production faults and resulting damages or consequential damages after the actuator has been tested and installed at the provided location and declared functional by the customer.

Warranty and liability claims shall be precluded in case of personal injury and property damage if they can be attributed to one or more of the following causes:

- improper use of the actuator or use other than intended,
- improper installation, start-up, operation, maintenance and cleaning of the actuator,
- insufficient testing of the installed actuator within the complete system,
- continued operation of the actuator even though malfunctions were detected during the initial or subsequent tests,
- failure to observe the operating manual and the notes in the operating manual referring to installation, start-up, operation and maintenance of the actuator,
- employment of unskilled personnel,
- disaster situations, influence of foreign objects and force majeure,
- improperly performed repairs,
- use of inadmissible spare parts and/or use of spare parts not in compliance with the technical requirements as defined,
- physical alterations, i.e. conversions, add-ons or other modifications of the actuator,
- technical modifications, i.e. changes to the actuator that lead to functional changes or changes in the application or performance characteristics.

## i

### **Important information regarding the EC conformity of the actuator**

The declaration of conformity and or declaration of incorporation issued by Agromatic Regelungstechnik GmbH shall become void if the customer performs structural or technical modifications to the actuator. In this case, the owner/lessor of the system himself shall be obliged to prove compliance with the relevant EC directives and issue an appropriate declaration of conformity.

#### **Exceptions:**

- use of an original retrofit kit (e.g. auxiliary switch)
- prior written approval of the modification to the actuator provided by Agromatic Regelungstechnik GmbH

We reserve the right to make technical changes as a result of improvements to the performance characteristics and further developments without prior written notice.

## 2 Safety

### WARNING

**Failure to observe the safety instructions below may have serious consequences:**

- Danger to persons from electrical or mechanical influences
- Failure of essential functions

Carefully read the safety instructions and hazard warnings in this section before commissioning the actuator.

Observe the general safety instructions and regulations for the prevention of accidents in addition to the instructions in this operating manual.

The owner/lessor and the user must observe the existing national work, operating and safety instructions in addition to the instructions in this operating manual. Any existing internal factory specifications must also be followed.

### 2.1 General safety instructions

- The actuators are designed exclusively for industrial use.
- Be sure to always read this operating manual before installing, operating, servicing, checking, troubleshooting, dismantling or disposing the actuator.
- Always observe all applicable safety instructions and regulations for the prevention of accidents such as the guidelines of professional associations for occupational safety and health when installing, operating, servicing, checking, troubleshooting, dismantling or disposing the device.
- Always disconnect any machinery and installations that may be affected before starting to work on the actuator.

## 2.2 Intended use

The operating safety of the actuator cannot be guaranteed unless it is used as intended.

The actuator has been designed for the automation of industrial valves (e.g. ball valves, dampers, other valves). Other applications shall only be permitted if approved by Agromatic Regelungstechnik GmbH.

The intended use also includes

- adherence to all instructions provided in the operating manual,
- adherence to the inspection and maintenance intervals,
- the use of resources and process materials in compliance with the safety instructions in force,
- adherence to the operating and maintenance requirements.

The technical data mentioned in the section “3.4 *Technical data*” must be adhered to without exception.

Any use of the actuator other than the intended use described in this document shall not be permitted and will be regarded as misuse.

Agromatic Regelungstechnik GmbH shall not accept liability for any damage resulting from such misuse. The owner/lessor shall bear the sole risk for possible damage due to improper use.

### Foreseeable misuse

- ✘ *It is not permitted to use the actuator in hazardous areas!*
- ✘ *It is forbidden to use the actuator as an ascending aid!*

## 2.3 Residual risks

The actuator has been built according to the state of the art and recognized safety regulations. Nevertheless, use of the device may still entail danger to users' or third parties' life and limb and/or result in impairments of the actuator itself or other material assets.

Only use the actuator

- for its intended use (see section “2.2 *Intended use*”) and
- in perfect technical condition in accordance with the safety regulations.

Malfunctions which may compromise safety must immediately be eliminated.

## 2.3.1 Hazards from electrical energy

### DANGER

#### Warning of dangerous electrical voltage!

Direct contact with live parts or with parts that became energized due to faults poses an immediate threat to life. Damage to the insulation or to individual components may be life-threatening. In case of short circuits/overloads there is the risk of being hit by molten parts being ejected.

- Always ensure that the electrical supply units remain locked. Only authorized persons with a key or special tool are permitted to access the units.
- Work on the electrical actuator equipment may only be carried out by a qualified electrician.
- Always operate the actuator with the hood in place.
- When working on live components or lines, a second person must always be present to interrupt the power supply in case of an emergency.
- Regularly inspect the electrical equipment of the actuator for defects such as loose connections or damaged insulation.
- Immediately disconnect the power supply in case of defects, and have the device repaired.
- Always switch off the power supply to the electrical actuator equipment and verify its voltage-free condition before carrying out any work on it.
- Switch the power supply off before carrying out service and repair work, and protect it from being switched on again.
- Do not bypass any fuses and do not put fuses out of operation.
- Ensure the correct tripping current when replacing fuses.
- Protect live parts from humidity as it may cause short circuits. Never clean electrical equipment with water or similar liquids.
- Have electrical machinery and stationary electrical equipment checked by a qualified electrician at least every 4 years (also refer to the section “8.2.1 Maintenance intervals”).
- Modifications made after the inspection must comply with the applicable standard.



## 2.3.2 Danger from moving parts

### WARNING

#### **Moving components on the actuator and the valves connected to it pose a risk of injury!**

When the actuator is operated, the valves connected to it will also move.

When couplings are used between the actuator and the valve, there is a risk of injury due to moving parts.

The dangers include crushing, shearing off or drawing in of the upper limbs.

- The installation or start-up of a damaged actuator is not permitted.
- Attach covers over the exposed moving actuator parts and the valve once the actuator is installed before putting the actuator into service. Observe DIN EN ISO 13857 (“Safety of machinery – Safety distances to prevent hazard zones being reached by upper and lower limbs”) when designing the protective covers.
- The heat dissipation of the actuator must be ensured when additional protective covers are installed. Non-observance may cause damage to the actuator (e.g. due to overheating of the motor windings).
- Verify the proper function of all protective equipment on your machine/plant.
- Verify the correct operation of the actuator and of the valves moved by the actuator after the assembly and the actuator setup are completed.
- Always operate the actuator with the hood in place.

### 2.3.3 Protection classes IP65 (standard), IP66 (option)



#### The actuator may not be put into service unless

- the hood is properly installed, and
- the screwed cable glands are plugged and have been checked for tightness.

#### NOTE

- To be able to ensure that protection class IP65 or IP66 is permanently complied with, the actuator must be protected against mechanical influences, e.g. by attaching safeguards or installing the actuator in a protected location.
- Outdoor installation of the actuator is only permitted if approved by Agromatic Regelungstechnik GmbH.
- Protect the actuator against environmental influences such as UV radiation, humidity, formation of condensation, fluctuations of temperature, and frost.
- The heat dissipation of the actuator must be ensured when additional protective covers are installed. Non-observance may cause damage to the actuator (e.g. due to overheating of the motor windings).

The following items **must always** be observed for all actuators:

#### Screwed cable glands

- The actuator has screwed cable glands size M20 x 1.5 and/or M16 x 1.5 and filler plugs (where required) to allow connection lines to be inserted.
- Always cover the cable glands properly before storing, installing and starting up the actuator.
- Only use connection lines with an outer diameter suitable for the cable glands.
- When cable glands/filler plugs are to be replaced or retrofitted, the replacement parts must be certified for the actuator's protection class.

#### Installing the hood

- See section *"5.8 Installing the hood"*.

#### Housing/hood

- Swapping hoods of different actuators is not permitted.
- Do not drill any holes into the actuator housing or the hood.

## 2.4 Personal protective equipment

Personal protective equipment must be worn when starting up and operating the actuator to minimize exposure to a variety of hazards.

- When working, always wear protective equipment that is required for the kind of work being carried out.
- Observe the instructions regarding protective equipment displayed in the work area.

The symbols have the following meaning:



### **Industrial protective clothing**

Industrial protective clothing is tightly fitting clothing with low tear strength, tightly fitting sleeves and no protruding parts. Its main function is to protect against being caught by moving components.

Do not wear rings, necklaces or other jewelry.



### **Safety shoes**

Wear anti-skid safety shoes to protect yourself from heavy, falling parts or slipping on slick surfaces.



### **Protective gloves**

Wear protective gloves to protect your hands against contacting hot surfaces or chemical substances.

## 2.5 Notes for emergencies

### Preventive measures

- Always be prepared for accidents or fires.
- Keep the first aid equipment (first aid kit, blankets, etc.) and fire extinguishing substances close at hand.
- Have the personnel instructed in the proper use of accident reporting, first aid, fire extinguishing and rescue equipment.
- Keep the access paths clear for emergency vehicles.

### Measures in case of accidents

- Set off an emergency stop.
- Remove all persons from the danger zone.
- Immediately take first aid actions in case of a cardiac or respiratory arrest.
- Immediately inform the first aid officer and an emergency doctor or the emergency medical service in case of personal injury.
- Clear the access paths for emergency vehicles. Assign a person to instruct the rescue forces if required.
- Extinguish burning oil or grease with a CO<sub>2</sub> fire extinguisher or a dry powder extinguisher.
- Extinguish a fire within the electrical control using a CO<sub>2</sub> fire extinguisher.

## 2.6 Obligations of the owner/lessor

The actuator is designed for industrial use. The owner/lessor of the actuator is therefore legally obligated to maintain safety at work.

In addition to the safety instructions provided in this operating manual, the safety instructions, instructions for the prevention of accidents and the environmental legislation in effect at the area of use of the actuator must be complied with. The following shall apply in particular:

- The owner/lessor must ensure that the actuator is operated according to its intended use (see section “2.2 *Intended use*”).
- The owner/lessor must ensure that the actuator's operating manual is always available in complete and readable form in the area of use of the actuator.
- The owner/lessor must keep himself informed about the locally applicable industrial safety regulations and carry out a hazard assessment to investigate additional risks resulting from the specific work conditions in the area of use of the actuator. The hazard assessment must then be implemented in the form of operating instructions for the operation of the actuator.
- During the entire service life of the actuator, the owner/lessor must verify that the operating instructions created by him comply with the current level of the technical standards and adjust the instructions where required.
- The owner/lessor must clearly define and control the responsibilities for installing, starting up, operating and servicing the actuator.
- The owner/lessor must ensure that the maintenance intervals described in this operating manual are adhered to.
- The owner/lessor may allow only sufficiently qualified and authorized personnel to work on the actuator.
- The owner/lessor must ensure that all employees handling the actuator have thoroughly read and understood the operating manual. In addition, he must at regular intervals verifiably train and inform the personnel about any risks involved.
- The owner/lessor must provide personal protective equipment to his employees and make sure that they use the equipment.
- The owner/lessor must ensure that employees under influence of drugs, alcohol, medication or similar substances are not allowed to work on the actuator.

## 2.7 Requirements imposed on the personnel

The actuator may be operated and serviced only by personnel that have been trained, instructed and authorized for this purpose. Such persons must know the operating manual and act according to it. The employees' responsibilities must be clearly defined.

### 2.7.1 Responsibilities

The following qualifications are designated for different areas of activity:

#### **Person to be trained**

A person in training such as a trainee or a temporary worker does not know all the dangers that may occur during operation of the actuator. Therefore, they may only carry out work on the actuator under the supervision of professional staff.

#### **Instructed person**

Such persons have been trained by the owner/lessor in the tasks assigned to them and informed about potential risks resulting from improper behavior.

#### **Professional staff**

Due to their technical training, knowledge and experience and their understanding of the applicable regulations, professional staff are able to carry out the work assigned to them and identify and avoid potential dangers on their own.

#### **Qualified electricians**

Due to their technical training, knowledge and experience and their understanding of the applicable regulations, qualified electricians are able to carry out the work assigned to them on electrical equipment and identify and avoid potential dangers on their own.

Qualified electricians are trained for their specific job site and know the applicable standards and regulations.

## 2.7.2 Qualifications required of the personnel

### **WARNING**

#### **Danger of injury in case of insufficient qualification!**

Improper handling can result in serious personal injury.

Therefore, ensure that all tasks are carried out only by appropriately qualified personnel.

Only persons who are expected to be capable of reliably carrying out their work shall be approved as personnel. Persons whose ability to react is impaired by drugs, alcohol, medication or similar substances shall not be allowed to work on the actuator.

Operational staff in training may initially only work on the actuator under the supervision of professional staff. Their successful completion of training must be confirmed in writing.

**Special qualifications are additionally necessary for the following activities:**

- **Installation:**  
may only be carried out by a qualified technician.
- **Start-up:**  
may only be carried out by an authorized electrician.
- **Maintenance:**  
may only be carried out by a qualified technician.
- **De-commissioning, disposal:**  
may only be carried out by a qualified technician.

## 2.7.3 Obligations of the personnel

All persons working on the actuator must

- adhere to the basic regulations regarding safety at work and the prevention of accidents,
- read the safety instructions and warnings in this operating manual before commencing work, and
- confirm with their signature that they fully understand all the instructions.

# 3 Product description

## 3.1 Product series

The actuator is available in two product series:

**NL:** Rotary and part-turn actuator (8 to 40Nm)

**NL with additional gearbox:** Rotary and part-turn actuator (60 to 120Nm)

## 3.2 Overview

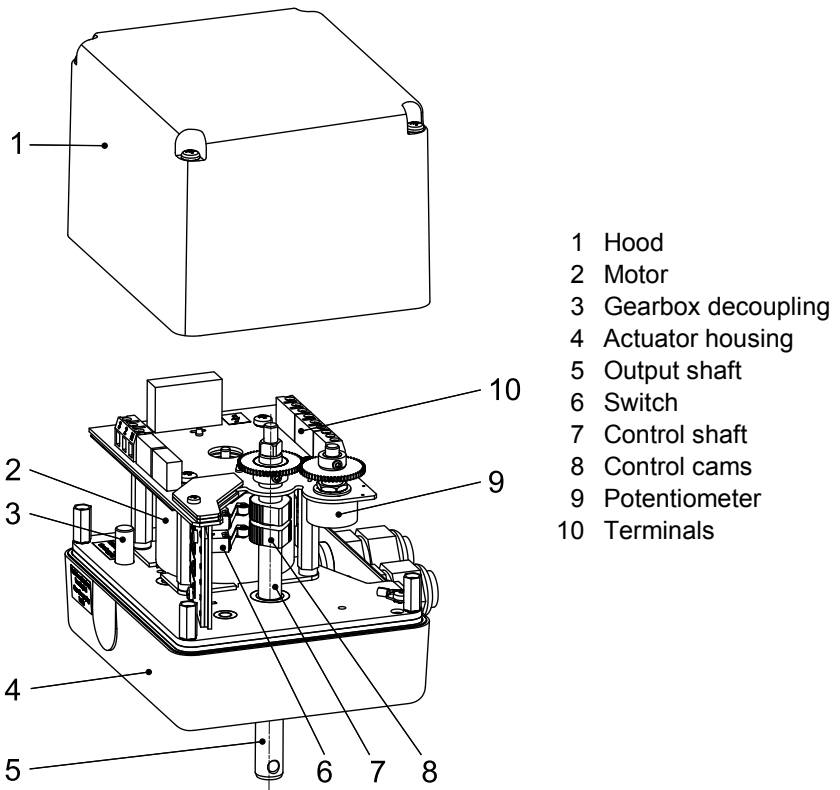

Fig. 3.1: Basic structure series NL

## 3.3 Functional description

The actuator has been designed to operate industrial valves (e.g. dampers, ball valves, other valves) within the positioning range determined by the mechanical characteristics of the valve. Depending on the design of the actuator, it is possible to move only to the valve end positions or to any position between the end positions.

The actuator can be installed in any orientation.

The actuator is installed either using a bracket or an adapter but can also be attached directly to the valve if required. If a bracket is used, the actuator is mounted to the valve by means of a coupling.

Different brackets are available for various requirements.

In case of a power failure the actuator can be operated manually by a hand-wheel (option, see section “7.1.1 Handwheel”).

## 3.4 Technical data

### 3.4.1 Dimensions

For details on the dimensions of the relevant series and type see section “5.2 Installation”.

### 3.4.2 Weight

Depending on the customer-specific actuator model, however max.:

**NL** 4.5kg

**NL with additional gearbox** 6.5kg

### 3.4.3 Housing

Protection class acc. to DIN EN 60529

- IP65 (standard)
- IP66 (option)

### 3.4.4 Actuator motor

#### Alternating current



#### Important information!

Frequency fluctuations affect the positioning time of the device.

Synchronous motor with permanent-magnet rotor

230V AC  $\pm 10\%$ , 50/60Hz  $\pm 5\%$

115V AC  $\pm 10\%$ , 50/60Hz  $\pm 5\%$

Duty cycle: see nameplate of the actuator

#### NOTE

- The specified voltage range of  $\pm 10\%$  must always be maintained!
- An overload of the actuator and strong voltage fluctuations may result in a reversal of the rotational direction of the motor. This could damage the actuator and/or the valve.

### 3.4.5 Functional data

#### Torques and positioning ranges

<b>NL</b>	Torque:	8 to 40Nm
	Positioning times:	6s/90° to 60s/90°
	Turn/swivel range:	max. 10 turns
<b>NL with additional gearbox</b>	Torque:	60 to 120Nm
	Positioning times:	18s/90° to 90s/90°
	Turn/swivel range:	max. 3 turns



#### Important information!

The torques specified above are nominal values. They are reached when the supply voltage corresponds to the rated voltage.

In some cases, the actual torque may be higher than the rated torque!

**Gearbox**

Maintenance-free steel spur gearing

**Installation position**

Any orientation

**Switch**

- Switch function: changeover switch (NC/NO contact)
- Switching capacity: max. 6A, 250V AC

Switches with gold-plated contacts are available for small switching loads and low voltages.

**i****Important information!**

Limit switches and auxiliary switches are **not** suitable as signal encoders for safety-related controls!

**Ambient temperature**

–15°C to +60°C (standard)

Up to –40°C with anti-condensate heater (option, consultation required)

Up to +80°C with limited duty cycle (option, consultation required)

**Actuators with electronic mounting parts:**

0°C to +60°C (standard)

Up to –15°C with anti-condensate heater (option, consultation required)

**Environmental conditions**

See section “2.3.3 Protection classes IP65 (standard), IP66 (option)”.

**Installation height**

≤ 2000m above sea level (standard)

> 2000m above sea level (option, consultation required)

**3.4.6 Airborne noise emission**

The airborne noise emission level induced by the actuator is < 70dB(A).

## 3.5 Nameplate

The nameplate provides all the important technical details for the actuator.



Every actuator is clearly identified by its serial number. The serial number can be found on the nameplate attached to the hood and on the nameplate located inside the actuator.

### i

#### Important information!

Please **always** quote the serial number indicated on the **nameplate inside the actuator** with your support enquiries to ensure that our Service department can provide optimum support to you.

Do **not** use the serial number indicated on the nameplate attached to the outside of the hood.

**The hoods of the actuators may not be swapped!**



## 4 Transportation and storage

The actuator is shipped to the customer by a shipping agent authorized by the manufacturer.

### 4.1 Acceptance inspection by the receiver

The actuator is shipped to the customer in a cardboard box.

If required, wire-mesh boxes are used for the transport (e.g. for delivering large quantities).

The customer must inspect the actuator for visual transport damage when receiving the product.

***Immediately notify the shipping agent and the manufacturer about any transport damage detected.***

### 4.2 Packaging, insulation

Packaging used for transporting and protecting the actuator is made of the following materials, which are suitable for re-use (recycling):

- Cardboard
- Styrofoam
- Polyethylene foil

**i**

**Important information!**

Always recycle packaging and insulation material in an environmentally friendly manner!

## 4.3 Transport instructions

### NOTE

#### **Risk of damaging the actuator!**

Improper handling may cause the control shaft of the actuator to be bent.

The control cams installed on the control shaft actuate the limit switches and the auxiliary switches. Therefore, any modification to the distance between the shaft and the switches will cause the switching points to be shifted.

For this reason:

- Always use the original packaging to transport the actuator.
- Always transport the actuator with the hood in place.
- Protect the actuator against strong vibrations such as may occur when the actuator is dropped.

## 4.4 Interim storage

The actuator must be stored carefully if it is not set up directly after delivery or temporarily not used.

- Always store the actuator in a well ventilated place in a dry room.
- Protect the actuator from humidity, dust and dirt.
- The formation of condensation and ice on the actuator must be prevented.

#### **When storing the device for more than 4 months:**

- Apply a long-term anti-corrosive agent on all bare parts of the actuator before storing it.
- Place a sufficiently dimensioned humidity absorber inside the actuator.

### **i**

#### **Important information!**

We will not accept any liability for damages caused by improper storage!

# 5 Assembly

## WARNING

### **Moving components on the actuator and the valves connected to it pose a risk of injury!**

When the actuator is operated, the valves connected to it will also move.

When couplings are used between the actuator and the valve, there is a risk of injury due to moving parts.

The dangers include crushing, shearing off or drawing in of the upper limbs.

- The assembly or operation of a damaged actuator is not permitted.
- Attach covers over the exposed moving actuator parts and the valve once the actuator is installed before putting the actuator into service. Observe DIN EN ISO 13857 (“Safety of machinery – Safety distances to prevent hazard zones being reached by upper and lower limbs”) when designing the protective covers.
- The heat dissipation of the actuator must be ensured when additional protective covers are installed. Non-observance may cause damage to the actuator (e.g. due to overheating of the motor windings).
- Verify the proper function of all protective equipment on your machine/plant.
- Verify the correct operation of the actuator and of the valves moved by the actuator after the assembly and the actuator setup are completed.
- Always operate the actuator with the hood in place.
- In order to reliably prevent an unexpected start-up of the actuator, the actuator's power supply may not be connected during the installation process.

## 5.1 General notes

### i

#### **Important information!**

In order to ensure safe operation of the actuator, the device should have a rated torque that is 15-20% higher than the torque required for adjusting the valve (for rated torques see section “3.4.5 *Functional data*”).

- Inspect the actuator for possible damage (e.g. transport damage) before installing it.
- If an anti-corrosive agent was applied for storing the actuator, it must be removed and replaced by grease before the device is installed.
- Protect the actuator against strong vibrations such as may occur when the actuator is dropped.
- It is forbidden to attach hooks, ropes or the like directly to the actuator.
- The actuator may not be lifted by the handwheel.
- Adhere to the installation instructions of the valve manufacturer.
- The valve must be able to move freely during the installation.

#### **NOTE**

#### **Risk of property damage when the gearbox is decoupled!**

The valve must not be twisted when the gearbox is decoupled. Decoupling cancels the holding torque of the motor, which may cause uncontrolled movements of the valve and damage the actuator gearbox.

- Where possible, avoid installing the actuator on an operating valve.
- If it is necessary to install the actuator in an operating system, all precautions must be taken to ensure that the system is in a safe condition (see operating instructions of the system and regulations provided by the system owner/lessor).
- If the actuator is attached to a freely accessible valve, the crushing and pinching hazards from rotating valve parts must be observed.
- If the actuator is to be attached to a valve not yet installed into a system, make sure that the valve is secured so that its stability is maintained during the installation of the actuator.

- Observe the screw-in depth of the mounting thread bores!
  - Series **NL**: min. 10mm, max. 12mm
  - Series **NL with additional gearbox**: min. 14mm, max. 16mm
- Check the cable glands and filler plugs (if fitted) for tightness before putting the actuator into service.
- Do not put the actuator into service unless the limit switches have been set.
- Protect the actuator sufficiently against climatic influences – e.g. by fitting a protective cover.
- Spark-quenching capacitors within the customer's power supply may influence the rotational stability of the actuator and cause damages to it.
- Only use original accessories from Agromatic Regelungstechnik GmbH for the actuator.

**NOTE****Risk of damaging the actuator!**

Improper handling may cause the control shaft of the actuator to be bent.

The control cams installed on the control shaft actuate the limit switches and the auxiliary switches. Therefore, any modification to the distance between the shaft and the switches will cause the switching points to be shifted.

For this reason:

- Do not use the control shaft to lift the actuator.
- Do not apply lateral forces or impact-like forces on the control shaft.
- Do not use the control shaft to rotate the actuator.

**Please note the following when installing couplings (not included in scope of delivery):**

- Do not use force to rotate the output shaft.
- The output shaft of the actuator and the valve shaft must run centrally! If this is not the case, a suitable coupling may be used to compensate any unbalance.

## 5.2 Installation

Agromatic rotary and part-turn actuators are designed for driving industrial valves (dampers, plug valves, etc.).

The actuator is installed either using a bracket and 4 screws or an adapter but can also be attached directly to the valve if required. Also be sure to follow the instructions in Fig. 5.1 and Fig. 5.2 on the following pages.

Actuator drive type	Nominal thread diameter	Property class	Screw-in depth	
			min.	max.
NL	M6	8.8	10mm	12mm
NL with additional gearbox	M6 M8	8.8	14mm	16mm

A bracket is required in the following cases:

- Valves for media with very high or very low temperatures
- Bypassing thick tube insulations

If a bracket is used, the actuator is mounted to the valve by means of a coupling. Various brackets and couplings (not included in the actuator scope of delivery) are available to match different requirements.

Always observe the installation instructions of the respective supplier when installing valves and brackets.

- Always ensure that the shafts of the valve and of the actuator are flush when installing the actuator. If there is a radial or angled offset of the shafts, a compensating coupling (not included in the scope of delivery) must be installed.
- Check the smooth running of the valve and the actuator after the valve shaft has been connected to the output shaft of the actuator.

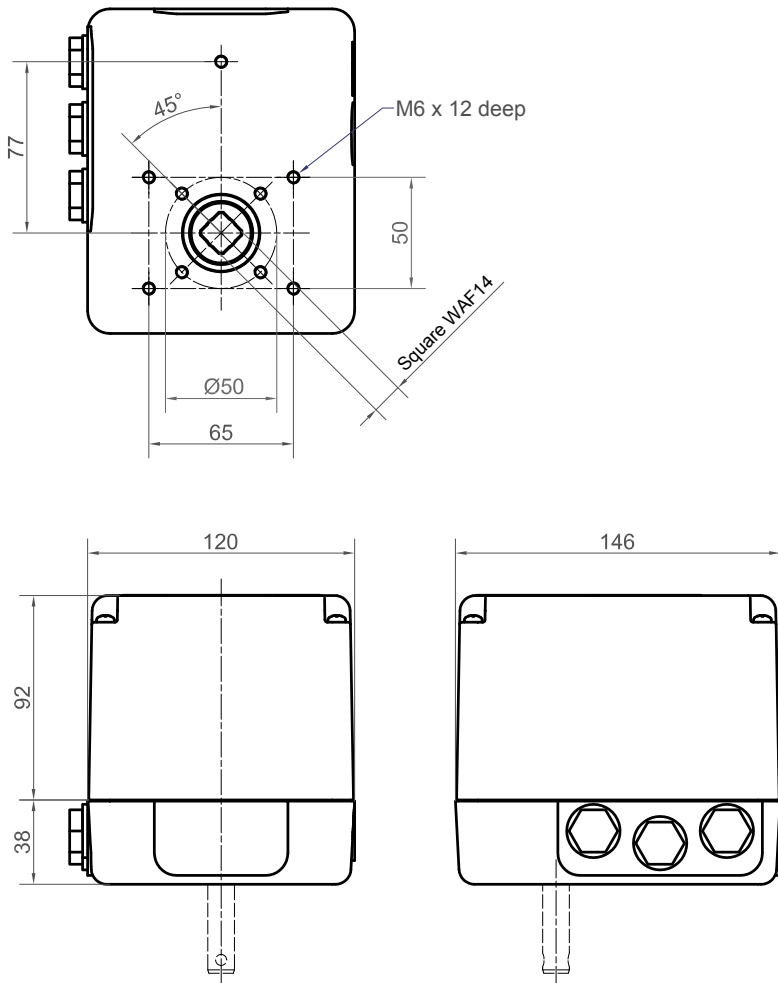

Fig. 5.1: Series NL – assembly dimensions

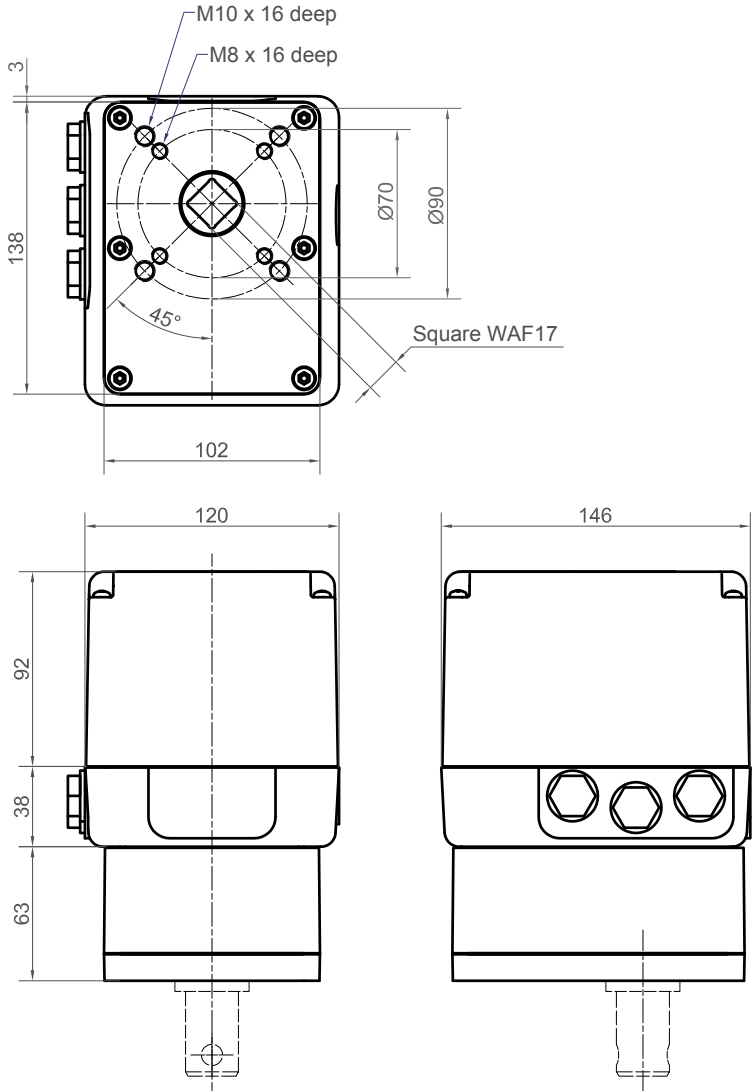

Fig. 5.2: Series NL with additional gearbox – assembly dimensions

## 5.3 Electrical connection

### DANGER

#### Warning of dangerous electrical voltage!

Working on live electrical devices poses a considerable risk of deadly or serious injuries!

If an actuator is open or operational, there is a risk of coming into contact with live parts (e.g. with a tool or another thin object).

- The electrical connection may only be established by a qualified electrician.
- Adhere to the regulations of the VDE (German Association for Electrical, Electronic and Information Technologies) and to the regulations issued by the local utility company.
- Make sure that no bare wires protrude from the terminals to eliminate the risk of electric shock or short circuits.



### **i**

#### Important information!

Limit switches and auxiliary switches are **not** suitable as signal encoders for safety-related controls!

### **i**

#### Important information!

For installation within a building, a switch must be provided as a separator according to DIN EN 61010-1 in order to disconnect the actuator before carrying out maintenance or troubleshooting work.

- This switch must be easily accessible for the user.
- The switch must be clearly identified as a separator.
- The separator must not interrupt the ground conductor!
- We strongly recommend installing a lockable switch.



#### Before

- switching the actuator **on** or **off**,
- changing any settings (e.g. rotational direction or swivel range) at the actuator,

check whether these actions could cause any dangerous movements within the machine/system or malfunctions of other assemblies!

- Check whether the type of current, mains voltage and mains frequency match the motor specifications. Refer to the nameplates on the hood and located inside the actuator.
- The power cord must be sized to suit the maximum power consumption of the actuator.
- Equip the actuator with an electric fuse protection suitable for the power cord used.
- Attach connection lines that match the screwed cable glands.
- Observe the minimum cable bend radius prescribed by the manufacturer.
- Always observe the schematic diagram attached inside the hood.
- Use separate shielded wires for low voltages (e.g. potentiometer).
- The control line for the actuator must not be routed in parallel with cables supplying the large loads. High amperages may generate electromagnetic fields which induce voltages into the control lines, thus causing actuator malfunctions.
- All internal electrical components (e.g. switches, potentiometers, relays, etc.) are factory-wired and routed to terminal strips where required.
- Follow the instructions in section “5.3.1 Determining the direction of rotation” for connecting the actuator.
- Adjust the position limit switches (see section “5.4 Setting the position switches”) before putting the actuator into operation.
- Protection class IP65 (standard) or IP66 (option) is guaranteed only if screwed cable glands are used which are approved for this protection class (see section “2.3.3 Protection classes IP65 (standard), IP66 (option)”).
- Use a ring cable lug to connect the ground conductor to the screw provided for this purpose and identified by the following symbol: 

**i****Important information!**

If several actuators are controlled by a common switching contact, every actuator must be equipped with an internal relay for parallel operation (see section “5.3.4 AC schematic diagram for parallel operation (option)”).

### 5.3.1 Determining the direction of rotation

**Initial connection of the actuator:**

- Make sure that the connected valve is approx. in the center of its positioning range.
- Check the direction of rotation.

**Direction of rotation**

- Viewing direction through the actuator towards the output shaft
- **Right-hand rotation:**  
The output shaft rotates in **clockwise** (CW) direction.
- **Left-hand rotation:**  
The output shaft rotates in **counterclockwise** (CCW) direction.
- **Direction of rotation** always refers to the **output shaft!**

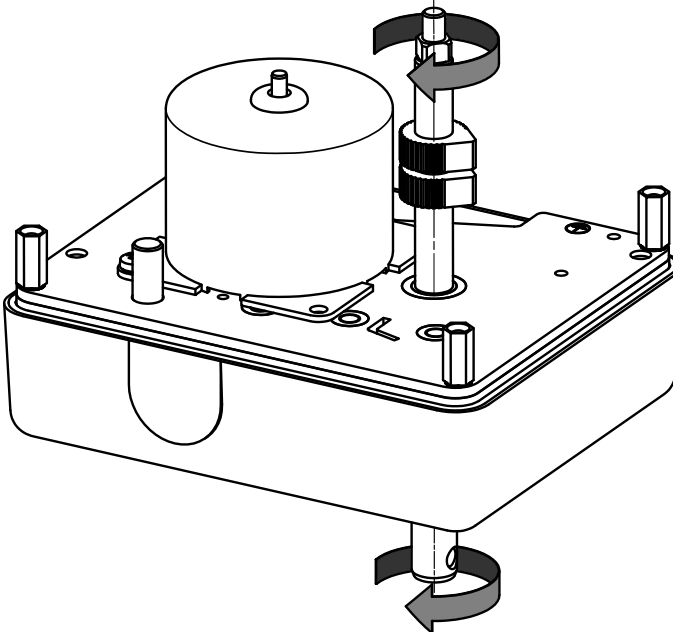
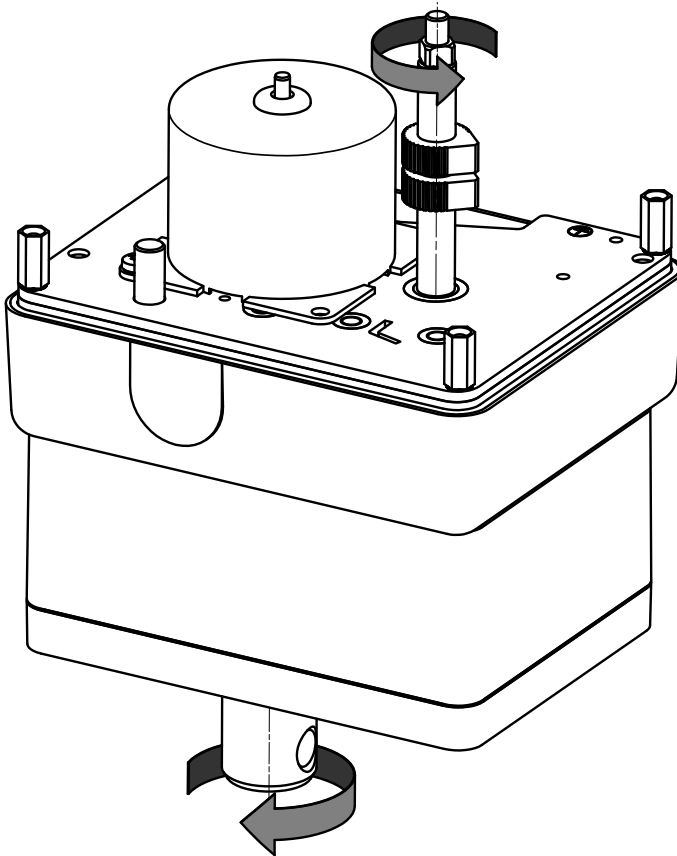

Fig. 5.3: NL – right-hand rotation, clockwise



*Fig. 5.4: NL with additional gearbox – right-hand rotation, clockwise*

**i**

**Important information!**

With actuators series N5 and N6, the control shaft turns in the opposite direction of the output shaft (see Fig. 5.4).

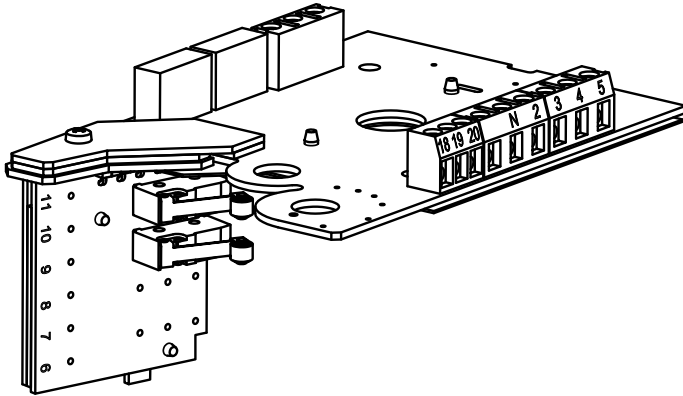

Fig. 5.5: PCB NL-Basic (design example)

### Left-hand rotation

- If mains voltage is applied between terminal **N** and **2**, the output shaft rotates in **left-hand direction** (CCW).
- This direction of rotation is limited by switch **SL**.
- When the switch is operated, mains voltage is applied to terminal **4**.

### Right-hand rotation

- If mains voltage is applied between terminal **N** and **3**, the output shaft rotates in **right-hand direction** (CW).
- This direction of rotation is limited by switch **SR**.
- When the switch is operated, mains voltage is applied to terminal **5**.

#### NOTE

If the actuator moves in opposite direction to the control commands, immediately interrupt the actuator's supply voltage and check the wiring by referring to the schematic diagram inside the hood.

Possible troubleshooting:

- For AC motors: interchange the external connections of terminal 2 and 3.

## i

### Important information!

Any modification to the internal wiring is strictly forbidden!

### 5.3.2 Schematic diagram for alternating current



**Important information!**

Always observe the schematic diagram attached inside the hood!

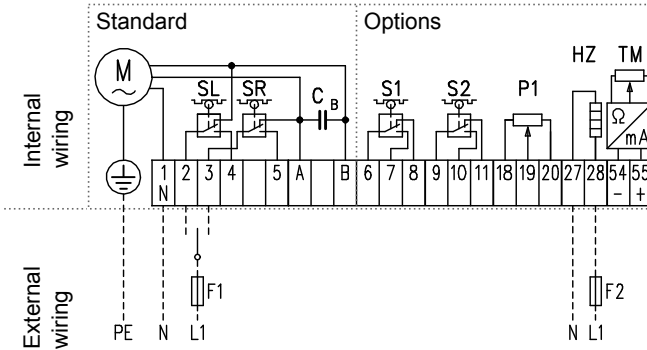

Fig. 5.6: Schematic diagram for alternating current

**Standard:**

- SL            limit switch CCW (left-hand) rotation
- SR            limit switch CW (right-hand) rotation

**Options:**

- S1, S2        auxiliary switch 1, auxiliary switch 2
- P1            potentiometer 1
- HZ            anti-condensate heater
- TM            current output (position feedback 4 ... 20mA)

Depending on the actuator model, the arrangement of the switches may vary from the configuration shown here. Always observe the schematic diagram attached inside the hood and the labeling of the switches on the PCB!

### 5.3.3 AC schematic diagram with service switch (option)

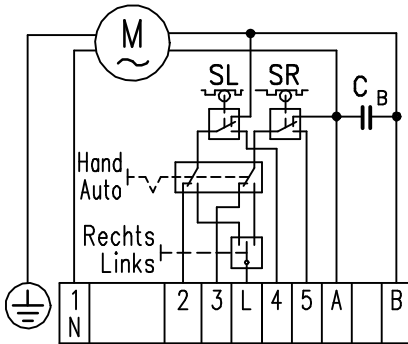

The service switch can be used to move the actuator irrespective of the control signals present at terminals 2 and 3.

- Hand = manual operation
- Rechts = right-hand operation (CW rotation)
- Links = left-hand operation (CCW rotation)

Fig. 5.7: AC schematic diagram with service switch (option)

### 5.3.4 AC schematic diagram for parallel operation (option)

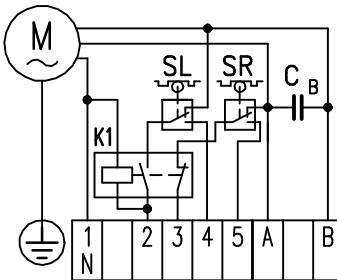

If several actuators are to be controlled by a common switching contact, every actuator must be equipped with a relay for parallel operation.

K1: relay for parallel operation

Fig. 5.8: AC schematic diagram for parallel operation (option)

## 5.4 Setting the position switches

If requested by the customer, the control cams can be factory-adjusted before delivery.

### i

#### Important information!

When moving to the end positions given by the position limit switches, ensure that the valve is securely closed when the actuator has reached the relevant end position!

#### NOTE

When the end position is reached, the motor must be disconnected from the power source, either by means of an internal limit switch or by an external control (see schematic diagrams, sections 5.3.2 to 5.3.4).

Different position-dependent cut-offs are used, depending on the actuator series and the positioning range:

- **Series NL:**
  - Positioning range  $< 330^\circ$  at the output shaft:  
see sections “5.4.2 Plastic control cam (standard)” and “5.4.3 Aluminum control cam (option)”
  - Positioning range  $> 330^\circ$  at the output shaft:  
See section “5.4.4 Threaded sleeve for a large positioning range (option)”.
- **Series NL with additional gearbox:**
  - Positioning range  $< 110^\circ$  at the output shaft:  
see sections “5.4.2 Plastic control cam (standard)” and “5.4.3 Aluminum control cam (option)”
  - Positioning range  $> 110^\circ$  at the output shaft:  
See section “5.4.4 Threaded sleeve for a large positioning range (option)”.

### 5.4.1 Control cam shapes and switches

In addition to the 330° standard cam (see Fig. 5.9) other control cam shapes are available on request, e.g. the 180° cam (see Fig. 5.10).

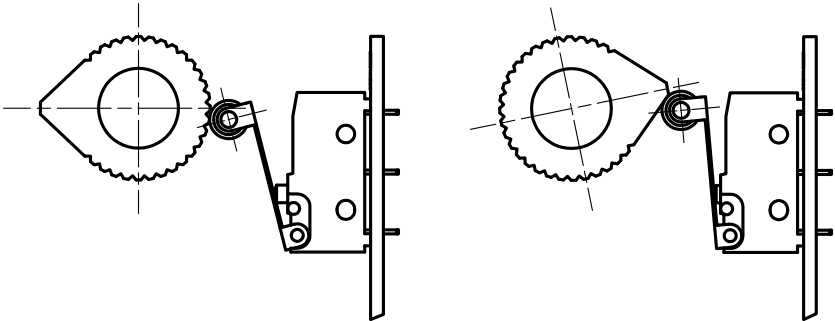

Fig. 5.9: 330° cam (left-hand: switch not activated, right-hand: switch activated)

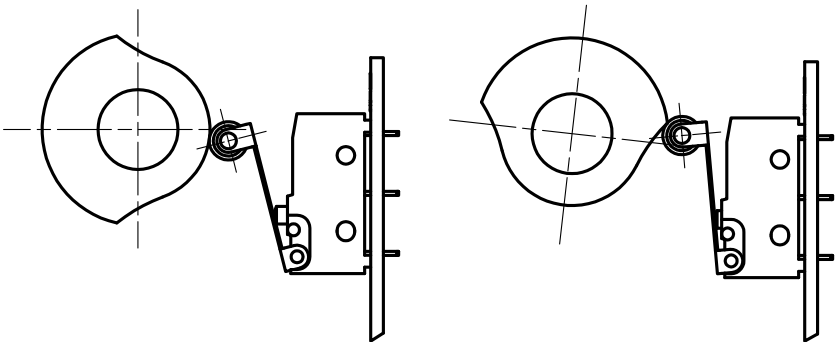

Fig. 5.10: 180° cam (left-hand: switch not activated, right-hand: switch activated)

The switches are equipped with a changeover contact.

**Switch activated:**      make contact (NO) closed,  
   break contact (NC) open

**Switch not activated:**    make contact (NO) open,  
   break contact (NC) closed

The control cams described below are always used for actuating the position switches that are dependent on the rotational angle.

## 5.4.2 Plastic control cam (standard)

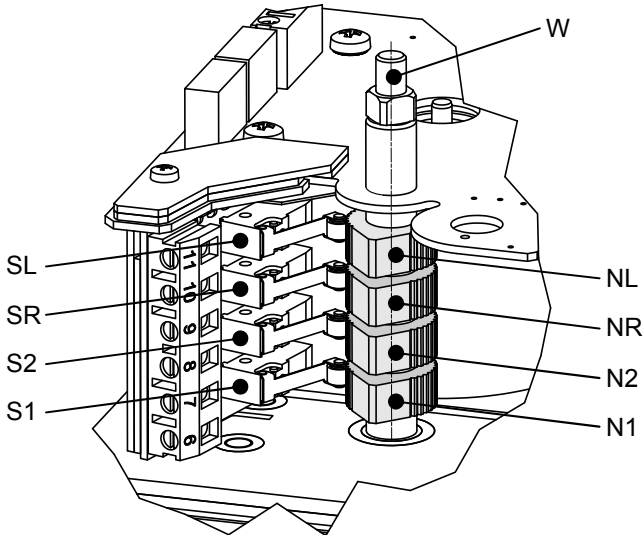

Fig. 5.11: Plastic control cam

The plastic control cam is used to actuate one position switch at a time.

The individual control cams are secured to the control shaft using an integrated O-ring and can be rotated by hand.

Fig. 5.11 shows a sample configuration for 2 position limit switches and 2 auxiliary position switches.

Different control cam shapes can be provided on request (see section “5.4.1 Control cam shapes and switches”).

### **i**

#### **Important information!**

Depending on the actuator model, the arrangement of the switches may vary from the configuration shown here. Therefore, always observe

- the schematic diagram inside the hood, and
- the labeling of the switches on the PCB.

**Setting the position limit switches**

1. Apply the voltage for CCW rotation (see section “5.3 *Electrical connection*”): The output shaft rotates in counterclockwise direction. Control shaft W rotates in the same or opposite direction of the output shaft, depending on the actuator type (see section “5.3.1 *Determining the direction of rotation*”).
2. Switch off the voltage as soon as the end position to be set has been reached. The valve must not block the actuator in this position!
3. Turn the control cam NL in the rotational direction of control shaft W until the position limit switch SL switches over (identified by an audible click within the switch).
4. Adjust control cam NR as described in steps 1 to 3 for CW rotation.
5. Electrically move to both end positions again to check the correct positions, and re-adjust the control cams where required.

**Setting the auxiliary position switches**

1. Move to the desired switch position in the rotational direction in line with the device function.
2. Turn control cam N1 in the rotational direction of control shaft W until auxiliary position switch S1 switches over (identified by an audible click within the switch).
3. Electrically move to the switch position again to check the correct position, and re-adjust the control cam N1 where required.

Set the control cam for the other auxiliary position switch as described in steps 1 to 3.

### 5.4.3 Aluminum control cam (option)

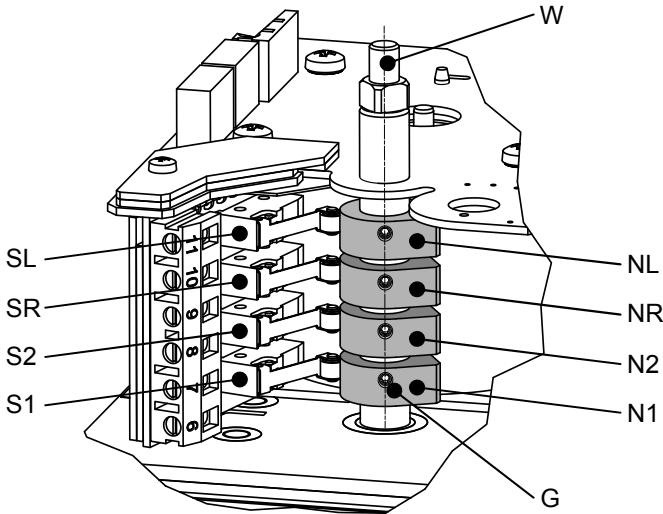

Fig. 5.12: Aluminum control cam (option)

The aluminum control cam is used for actuating one position switch at a time.

On delivery the individual control cams are loosely plugged onto the control shaft W. The cams are fixed using hex-socket grub screws G during the setting procedure. The grub screws are secured so they cannot fall out.

Fig. 5.12 shows a sample configuration for 2 position limit switches and 2 auxiliary position switches.

Different control cam shapes can be provided on request (see section “5.4.1 Control cam shapes and switches”).

## i

### Important information!

Depending on the actuator model, the arrangement of the switches may vary from the configuration shown here. Therefore, always observe

- the schematic diagram inside the hood, and
- the labeling of the switches on the PCB.

**Setting the position limit switches**

1. Apply the voltage for CCW rotation (see section “5.3 *Electrical connection*”): The output shaft rotates in counterclockwise direction. Control shaft W rotates in the same or opposite direction of the output shaft, depending on the actuator type (see section “5.3.1 *Determining the direction of rotation*”).
2. Switch off the voltage as soon as the end position to be set has been reached. The valve must not block the actuator in this position!
3. Turn the control cam NL in the rotational direction of control shaft W until the position limit switch SL switches over (identified by an audible click within the switch). Then fix the control cam using grub screw G.
4. Adjust control cam NR as described in steps 1 to 3 for CW rotation and fix it with grub screw G.
5. Electrically move to both end positions again to check the correct positions, and re-adjust the control cams where required.

**Setting the auxiliary position switches**

1. Move to the desired switch position in the rotational direction in line with the device function.
2. Turn control cam N1 in the rotational direction of control shaft W until auxiliary position switch S1 switches over (identified by an audible click within the switch). Then fix the control cam using grub screw G.
3. Electrically move to the switch position again to check the correct position, and re-adjust the control cam N1 where required.

Set the control cam for the other auxiliary position switch as described in steps 1 to 3.

### 5.4.4 Threaded sleeve for a large positioning range (option)

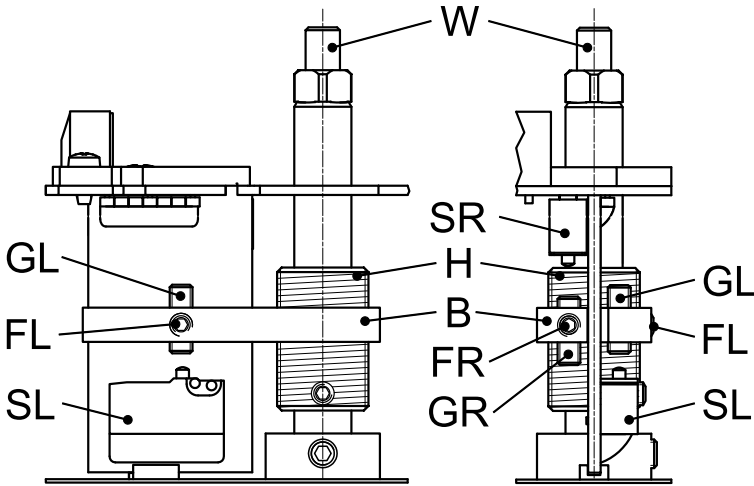

Fig. 5.13: Threaded sleeve for a large positioning range  $> 330^\circ$  (option)

Threaded plate B on threaded sleeve H actuates the two limit switches SL and SR. The threaded sleeve is necessary to extend the positioning range.

– **Series NL:**

Threaded sleeve required for positioning range  $> 330^\circ$  at the output shaft

– **Series NL with additional gearbox:**

Threaded sleeve required for positioning range  $> 110^\circ$  at the output shaft

## i

### Important information!

For actuators series **NL with additional gearbox**, the functions of switches SL and SR have been swapped.

- Switch **SR** is actuated in the **left end position** of the output shaft.
- Switch **SL** is actuated in the **right end position** of the output shaft.

### Setting the position limit switches

1. Apply the voltage for CCW rotation (see section “5.3 *Electrical connection*”): The output shaft rotates in counterclockwise direction. Control shaft W rotates in the same or opposite direction of the output shaft, depending on the actuator type (see section “5.3.1 *Determining the direction of rotation*”).
2. Switch off the voltage as soon as the end position to be set has been reached. The valve must not block the actuator in this position!
3. Setting the switching point of the left end position of the output shaft:
  - **Series NL:**  
Turn grub screw GL (hex-socket WAF 2.0) in the direction of bottom switch SL until SL switches over (indicated by an audible click within the switch). Then fix grub screw GL using grub screw FL (hex-socket WAF 2.0).
  - **Series NL with additional gearbox:**  
Turn grub screw GR (hex-socket grub WAF 2.0) in the direction of top switch SR until SR switches over (indicated by an audible click within the switch). Then fix grub screw GR using grub screw FR (hex-socket WAF 2.0).
4. Set the switching point for the right end position of the output shaft as described in steps 1 to 3 for CW rotation.
5. Electrically move to both end positions again to check the correct positions, and re-adjust the grub screws GR and GL where required.

# 5.5 Connecting and adjusting the potentiometer (option)

**⚠ DANGER**



**Warning of dangerous electrical voltage!**

Working on electrical devices poses a considerable risk of deadly or serious injuries!

- Only qualified electricians may carry out the work.
- Adhere to the regulations of the VDE (German Association for Electrical, Electronic and Information Technologies) and to the utility company's regulations locally in force.

**Electrical connection**

- Always connect the potentiometer with a shielded cable separated from the mains voltage lines.
- Observe the schematic diagram inside the hood.
- Terminals 18 and 20 may be swapped during wiring in order to match the potentiometer reading to the rotational direction of the actuator.

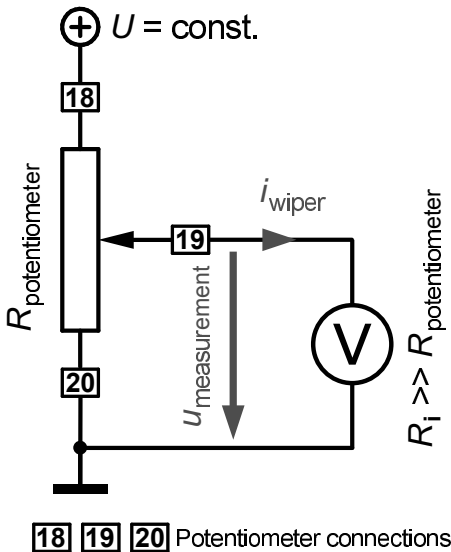

The maximum permitted wiper current of the potentiometer may not be exceeded.

The measuring electronics used for evaluating the potentiometer must therefore have a very high internal resistance  $R_i$ .

The required minimum internal resistance depends on the permitted wiper current and the constant voltage  $U$ .

The maximum permitted voltage is based on the maximum power rating and the rated resistance of the potentiometer.

$$U_{\max} = \sqrt{P_{\max} \cdot R_{\text{rated}}}$$

Fig. 5.14: Wiring of the potentiometer

**i****Important information!**

Potentiometers may only be operated as voltage dividers (see Fig. 5.14). Please refer to the schematic diagram inside the hood for information on the maximum permitted wiper current  $i_{\text{wiper}}$  and the maximum rated power  $P_{\text{max}}$  of the potentiometer.

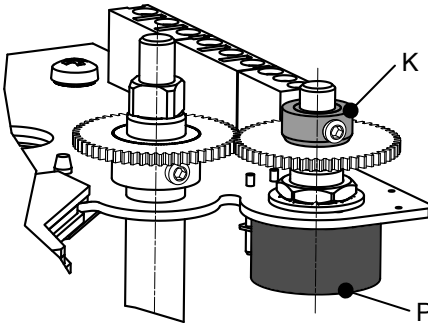
**Adjusting procedure**

An intermediate gear train transfers the positioning range of the actuator to the electrical angle of rotation of potentiometer P. A friction clutch K on the potentiometer shaft protects the potentiometer from being destroyed during the setting of the actuator.

Fig. 5.15: Adjusting the potentiometer

**NOTE**

**Observe the positioning range of the actuator and the potentiometer transmission ratio!**

**The order-specific positioning range must not be exceeded**, otherwise the potentiometer adjustment would be cancelled when moving to the end position. In this case, feedback of the correct position would no longer be possible.

1. Set the position limit switches (see section “5.4 Setting the position switches”) before adjusting potentiometer P.
2. First move the actuator electrically to the right end position, then to the left end position. Using friction clutch K, potentiometer P roughly adjusts itself during this process.
3. Electrically move to both end positions again and check the position of potentiometer P at each end position:
  - The potentiometer may not reach its mechanical stop in either end position.
  - Re-adjust the potentiometer using friction clutch K where required.

## 5.6 2-wire current output 4 ... 20mA (option)

### Electrical connection

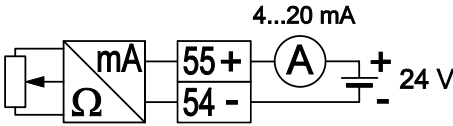

Fig. 5.16: Schematic diagram transmitter

Always connect the current output with a shielded wire (minimum cross-section 0.5mm<sup>2</sup>, maximum length 1000m) separated from the mains voltage lines.

### Adjusting procedure

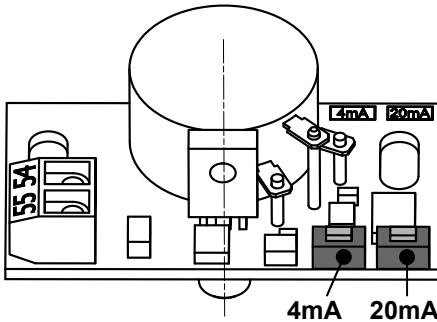

Fig. 5.17: Transmitter (top view)

- The current output is programmed with the two buttons **4mA** and **20mA**.
- The output currents 4mA and 20mA can be assigned to optional positions.
- The minimum and the maximum output current (4mA and 20mA) cannot be changed.

### End position 4mA

1. Move the actuator to the first end position.
2. Press button **4mA** for more than 2s, then release it.

The first end position is now assigned to the 4mA output current.

### End position 20mA

1. Move the actuator to the opposite end position.
2. Press button **20mA** for more than 2s, then release it.

The second end position is now assigned to the 20mA output current.

### NOTE

**Observe the positioning range of the actuator and the potentiometer transmission ratio!**

**The order-specific positioning range must not be exceeded**, otherwise the potentiometer adjustment would be cancelled when moving to the end position. In this case, feedback of the correct position would no longer be possible.

## 5.7 Anti-condensate heater (option)

The anti-condensate heater is a heating resistor. This resistor is connected to the mains voltage (terminals 27 and 28, see section “5.3.2 Schematic diagram for alternating current”) to generate the heat output.

### NOTE

If the ambient temperature varies during the installation, the heating resistor must be connected immediately to the voltage supply and remain connected during start-up to avoid condensation within the actuator.

### Heating resistor data:

$$U_{\text{heating\_resistor}} = 230\text{V}, P_{\text{heating\_resistor}} \approx 3\text{W}$$

Heating resistors with 24V/2W or 115V/3W are available as options.

## 5.8 Installing the hood

When all connecting and setting work has been completed, the hood must be installed again on the actuator using the four hood screws. Verify during the assembly that the serial number of the hood matches the serial number of the actuator.

The following defaults must be observed during the installation:

- Make sure that the circumferential sealing ring in the actuator housing is properly seated and undamaged.
- The hood must be undamaged, this applies in particular to the surface resting on the actuator housing.
- Evenly tighten the hood screws to the prescribed torque of 1Nm in a crosswise pattern.
- Different hood configurations are possible, depending on the protection class. Swapping hoods of different actuators is therefore not permitted.
- Before its installation or removal, the hood must be dry so as to protect the electrical components inside the actuator against humidity.

### i

#### Important information!

The hood screws are protected from falling out by an O-ring. They must **not** be pulled out of the hood!



# 6 Electronic position controller ESR-NL (option)

## 6.1 Description

The electronic position controller series ESR-NL integrated into the actuator housing has been designed to regulate the angle position of the actuator based on a setpoint specification. A potentiometer is used as an actual value encoder.

The setpoint can be specified as a DC current signal 0(4) ... 20mA (acc. to DIN IEC 60381-1) or optionally as a DC voltage signal 0(2) ... 10V (acc. to DIN IEC 60381-2).

In automatic mode the actuator continuously compares the specified position represented by the setpoint signal with the actual position of the actuator.

If – for example due to a new setpoint specification – the difference between the specified and the actual position is large enough, the position controller automatically moves the actuator to the specified position.

**i**

### Important information!

Limit and auxiliary switches and the potentiometer are **not set** on delivery!

Depending on the positioning range of the valve, the limit switches and the potentiometer must be set before they are put into operation:

- For limit switches see section 5.4.
- For potentiometer see section 5.5.

**i**

### Important information!

The position controller is **not programmed** on delivery!

To allow the position controller to regulate the position, the actions described below must be taken before start-up as described in section “6.2.6 Programming”.

- programming the end positions of the positioning range,
- setting the setpoint range and the direction of action, and
- the setpoints must be assigned to the end positions.

## 6.2 Electrical connection



Depending on the applied setpoint and the position of the actuator, the position controller starts to move the actuator immediately after the operating voltage has been switched on. This may cause possibly dangerous movements of the actuated valve.

Therefore, **always** set the position controller to **Manu** mode = manual mode (see page 54 “*Sliding switch Auto/Manu*”) **before** switching on the operating voltage of the actuator!

### DANGER

#### Warning of dangerous electrical voltage!

Working on live electrical devices poses a considerable risk of deadly or serious injuries!

If an actuator is open or operational, there is a risk of coming into contact with live parts (e.g. with a tool or another thin object).

- The electrical connection may only be established by a qualified electrician.
- Adhere to the regulations of the VDE (German Association for Electrical, Electronic and Information Technologies) and to the regulations issued by the local utility company.
- Make sure that no bare wires protrude from the terminals to eliminate the risk of electric shock or short circuits.



### **i**

#### Important information!

Limit switches and auxiliary switches are **not** suitable as signal encoders for safety-related controls!

### **i**

#### Important information!

For installation within a building, a switch must be provided as a separator according to DIN EN 61010-1 in order to disconnect the actuator before carrying out maintenance or troubleshooting work.

- This switch must be easily accessible for the user.
- The switch must be clearly identified as a separator.
- The separator must not interrupt the ground conductor!
- We strongly recommend installing a lockable switch.



### Before

- switching the actuator **on** or **off**,
- changing any settings (e.g. rotational direction or swivel range) at the actuator,

check whether these actions could cause any dangerous movements within the machine/system or malfunctions of other assemblies!

- Check whether the type of current, mains voltage and mains frequency match the motor specifications. Refer to the nameplates on the hood and located inside the actuator.
- The power cord must be sized to suit the maximum power consumption of the actuator.
- Equip the actuator with an electric fuse protection suitable for the power cord used (see Fig. 5.6).
- Attach connection lines that match the screwed cable glands.
- Observe the minimum cable bend radius prescribed by the manufacturer.
- Always observe the schematic diagram attached the hood.
- Use separate shielded wires for low voltages (e.g. setpoint, actual value) with a minimum cross-section of 0.5mm<sup>2</sup> and a maximum length of 1000m. One end of the shielding must be connected to the chassis ground of the actuator (grounding terminal).
- A minimum distance of 3mm must be maintained between the power line and the setpoint/actual value line. As an alternative, both lines can be fitted with insulation that matches the mains voltage.
- The setpoint line and the actual value cable for the actuator must not be routed in parallel with cables supplying large loads. High amperages may generate electro-magnetic fields which induce voltages into the control lines, thus causing actuator malfunctions.
- All internal electrical components (e.g. switches, potentiometers, relays, etc.) are factory-wired and routed to terminal strips where required.
- Follow the instructions in section “5.3.1 Determining the direction of rotation” for connecting the actuator.
- Protection class IP65 is guaranteed only if screwed cable glands are used which are approved for this protection class (see section “2.3.3 Protection classes IP65 (standard), IP66 (option)”).
- Use a ring cable lug to connect the ground conductor to the screw provided for this purpose and identified by the following symbol:



## 6.2.1 Schematic diagram

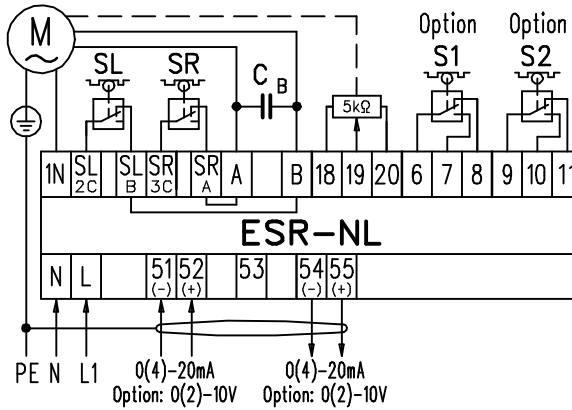

Fig. 6.1: Schematic diagram ESR-NL

### Standard:

M	motor of the actuator
ESR-NL	electronic position controller
SL	limit switch CCW (left-hand) rotation
SR	limit switch CW (right-hand) rotation
51, 52	setpoint input
54, 55	actual value output

### Options:

S1, S2	auxiliary switch 1, auxiliary switch 2
--------	--

## i

### Important information!

The auxiliary switches S1 and S2 must operate within an identical voltage range. Mixing mains voltage and low voltage is not permitted.

## 6.2.2 Controls and indicators

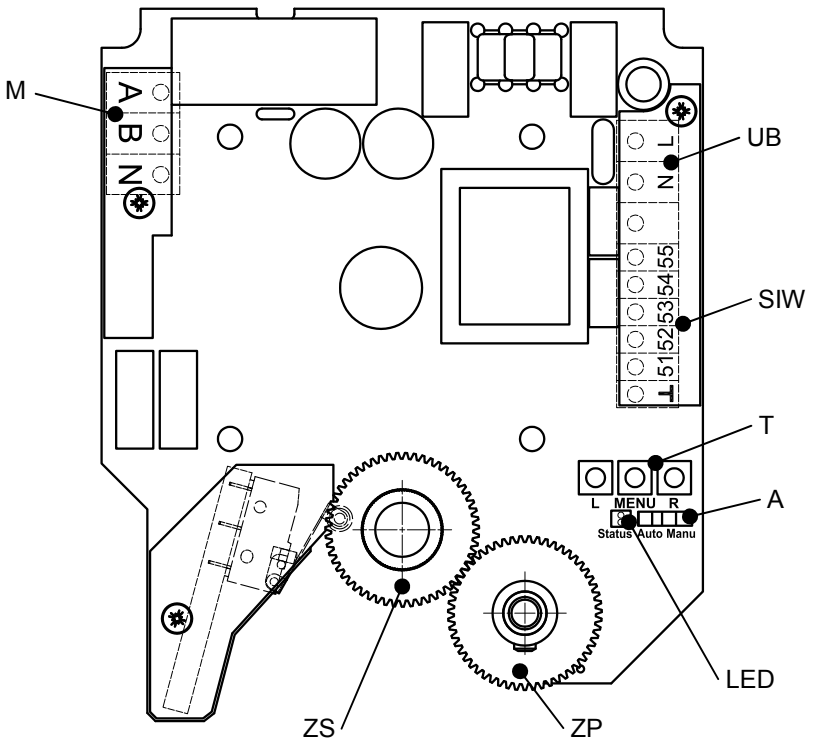

Fig. 6.2: PCB ESR-NL (design example)

M	motor terminal
UB	mains voltage terminal
SIW	terminal for setpoint and actual value
T	buttons for operating the position controller
A	Sliding switch <b>Auto/Manu</b>
LED	two-color LED indicating the status
ZS	gearwheel on control shaft
ZP	gearwheel on potentiometer shaft







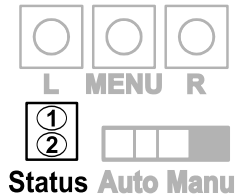
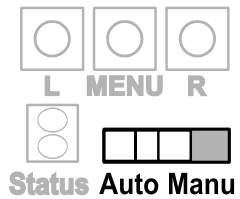
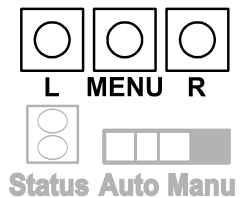

**Indicator LEDs**

1 = green LED

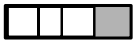
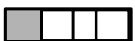
2 = red LED

**Controls****Sliding switch Auto/Manu****Auto** = automatic mode**Manu** = manual mode**Button block**Button **L** manual mode, CCW rotationButton **MENU** programming modeButton **R** manual mode, CW rotation**The buttons have no function in automatic mode.**

### 6.2.3 Depiction of the button, switch and LED statuses

No button pressed	 L MENU R
Button <b>MENU</b> pressed	 L MENU R
Sliding switches <b>Auto/Manu</b> in position <b>Auto</b>	 <b>Auto Manu</b>
Sliding switches <b>Auto/Manu</b> in position <b>Manu</b>	 <b>Auto Manu</b>
Green LED off Red LED off	
Green LED, slowly flashing Red LED off	
Green LED, quickly flashing Red LED off	
Green LED, quick double-flash Red LED off	
Green LED off Red LED continuously on	

## 6.2.4 Setting the limit switches and the potentiometer



Before

- the limit switches are adjusted,
  - the potentiometer is adjusted,
- the sliding switch **Auto/Manu** must be set to the position **OFF = manual mode!**



**Auto Manu**

### Setting the position limit switches

For details on how to adjust the position limit switches, also see section “5.4 Setting the position switches”.

1. Move the actuator to the left end position of the valve using buttons **L** and **R**. The valve must not block the actuator in this position!
2. Turn control cam NL in the rotational direction of control shaft W until limit switch SL switches over (identified by an audible click within the switch).
3. For CW rotation, set control cam NR for the right end position of the valve as described in steps 1 and 2.
4. To check the correct positions, move to both end positions again electrically using buttons **L** and **R**, and re-adjust the control cams where required.

### Adjusting the potentiometer

By moving again to both end positions as described in step 4, potentiometer P is roughly adjusted using friction clutch K (also see section “5.5 Connecting and adjusting the potentiometer (option)”).

5. Move once again to the two end positions using buttons **L** and **R**, and check the position of potentiometer P at each end position:
  - The potentiometer may not reach its mechanical stop in either end position.
  - Re-adjust the potentiometer using friction clutch K where required.

## i

### Important information!

Note that for actuators with threaded sleeves instead of control cams, it is essential to observe section “5.4.4 Threaded sleeve for a large positioning range (option)”!

## 6.2.5 Setpoint value input and actual value output

The ESR-NL is delivered in one of 4 versions according to the order:

<b>Version</b>	<b>Setpoint</b>	<b>Actual value</b>
1 (standard)	0(4) ... 20mA	0(4) ... 20mA
2	0(2) ... 10V	0(2) ... 10V
3	0(4) ... 20mA	0(2) ... 10V
4	0(2) ... 10V	0(4) ... 20mA

A subsequent change of version is only possible at the factory. In this case, please contact our Service department (see page 77).

The actual value output is electrically isolated from the setpoint input.

The end positions can either be assigned to fixed setpoints (0mA, 4mA, 20mA) or optionally defined setpoints within the range of 0 ... 20mA (see also page 59 “*Selecting the setpoint for the left end position*” and page 60 “*Selecting the setpoint for the right end position*”).

### **i**

#### **Important information!**

If no setpoint is applied in automatic mode, the actuator moves to the end position assigned to setpoint 0(4)mA.

## 6.2.6 Programming

The programming procedure is used to assign the setpoints 0(4)mA and 20mA (or 0(2) V and 10 V) to the two end positions of the positioning range. The setpoint can also be freely assigned in the range of 0 ... 20mA (see also page 59 “*Selecting the setpoint for the left end position*” and page 60 “*Selecting the setpoint for the right end position*”).

For series NL, the positioning range can be between 90° and 330°, depending on the potentiometer transmission ratio. The actuator can be ordered with special equipment to allow multiple turns (see sections “3.4.5 *Functional data*” and “5.4.4 *Threaded sleeve for a large positioning range (option)*”).

The positioning range limited by the programmed end positions of the position controller should cover at least 50% of the nominal positioning range of the actuator specified on the nameplate.



The cams of switches SL and SR must be set and the potentiometer must be adjusted before the end positions of the positioning range of the position controller can be programmed!



Before

- the end positions are programmed,
  - the setpoint range is set,
  - the direction of action is set,
- the sliding switch **Auto/Manu** must be set to the position **OFF = manual mode!**

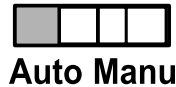

**i**

### Important information!

The entire programming sequence must be run through from start to end. Separate programming of individual values is not possible.

### Activating the programming mode

1. In manual mode (sliding switch set to **Manu**), press button **MENU** for 5s.

► Red LED, quick double-flash

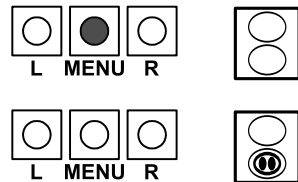

### Programming the left end position

2. Move to the left end position by pressing button **L**.

If the end position is overrun, the actuator must be moved far enough in reverse direction using button **R**.

Then move again to the left end position.

3. Press button **MENU**.

The left end position is now programmed.

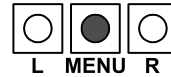

### Selecting the setpoint for the left end position

4. Select the setpoint for the left end position by pressing button **L** several times (if required).

▶ 0mA

▶ 4mA

▶ 20mA

▶ Freely specified via an externally applied setpoint value

5. Press button **MENU** to confirm the setpoint for the left end position.

▶ Green LED, quick double-flash



### Programming the right end position

6. Move to the right end position by pressing button **R**.

If the end position is overrun, the actuator must be moved far enough in reverse direction using button **L**.

Then move again to the right end position.

7. Press button **MENU**.

The right end position is now programmed.

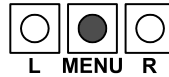

### Selecting the setpoint for the right end position

8. Select the setpoint for the right end position by pressing button **L** several times (if required).

Only setpoints that logically complement the setpoint for the left end position selected in step 4 can be selected now.

- ▶ 0mA
- ▶ 4mA
- ▶ 20mA
- ▶ Freely specified via an externally applied setpoint

9. Press button **MENU** to confirm the setpoint for the right end position.



**Setting the actual value range 0 ... 20mA or 4 ... 20 mA**

<p>10. Select the actual value range for the right end position by pressing button <b>L</b> several times (if required).</p> <ul style="list-style-type: none"> <li>▶ 4 ... 20mA</li> <li>▶ 0 ... 20mA (LEDs flash alternately)</li> </ul> <p>11. Press button <b>MENU</b> to confirm the actual value range.</p>	
---	--

**Assigning actual value 0(4)mA or 20mA to the end positions**

<p>12. Pressing button <b>L</b> several times (if required) to assign actual values to the end positions:</p> <ul style="list-style-type: none"> <li>▶ 0(4)mA = right end position 20mA = left end position</li> <li>▶ 0(4) mA = left end position 20 mA = right end position</li> </ul> <p>13. Press button <b>MENU</b> to confirm the assignment and complete the programming sequence.</p>	
---	--

**Activating automatic mode**

<p>Set sliding switch <b>Auto/Manu</b> to the position <b>Auto</b> = automatic mode to switch the position controller to automatic mode.</p> <p>This position is then regulated by means of the set-point applied.</p>	
--	--

## 6.2.7 Resetting the controller programming

Resetting the controller programming (“Reset”) deletes all the parameters stored when programming the position controller. After a reset the position controller must be programmed again (see section “6.2.6 Programming”).



Before the position controller can be reset, sliding switch **Auto/Manu** must be set to the position **Manu = manual operation!**



**Auto Manu**

### Performing a reset

1. Switch off the operating voltage.
  2. Press button **MENU**.
  3. Switch on the operating voltage while button **MENU** is pressed. Hold the button down.
    - ▶ Red LED shines continuously
  4. Hold button **MENU** down.
    - ▶ After approx. 5s the green LED also lights up.
  5. Release button **MENU**.
    - ▶ Green LED flashes, red LED shines continuously.
- Reset is completed.

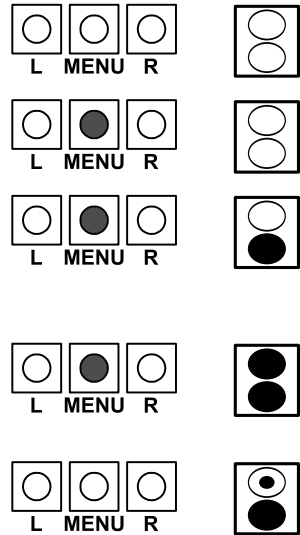





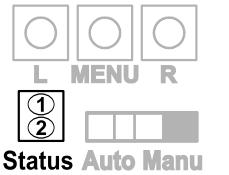

## 6.2.8 LED status indicator

### Indicator LEDs

<p>1 = green LED</p> <p>2 = red LED</p>	
---	--

### If operating voltage is applied

<i>Mode</i>	<i>Button</i>	<i>Function</i>	<i>Setpoint</i>	<i>Green LED</i> <i>Red LED</i>
Manu	–	–	*	
Manu	<b>R</b>	Move actuator clockwise	*	
Manu	<b>L</b>	Move actuator counterclockwise	*	
Auto	*	Actuator moves clockwise	Setpoint for CW rotation, specified position not yet reached	
Auto	*	Actuator moves counterclockwise	Setpoint for CCW rotation, specified position not yet reached	
Auto	*	–	With setpoint applied, specified position reached	
Manu	–	– Reset completed – Programming faulty	*	

Key to symbols:

\* no effect, ● on, ○ off, ⊙ slowly flashing, ⊕ quickly flashing

In **Auto** = automatic mode, buttons **L**, **SET** and **R** are always functionless.

## 6.3 Technical data ESR-NL

### Operating voltage

230V AC  $\pm 10\%$ , 50/60Hz  $\pm 5\%$

115V AC  $\pm 10\%$ , 50/60Hz  $\pm 5\%$

### Setpoint input

- Current input: 0(4) ... 20mA
  - internal burden resistor: 250 $\Omega$
  - overload protection 25mA
  - reverse polarity protection up to  $-25\text{mA}$
- Voltage input: 0(2) ... 10V (option)
- Limited overvoltage and reverse polarity protection
- Resolution: 10 bits

### Actual value output

- Actual value encoder: conductive plastic or wire-wound potentiometer  
1 ... 10k $\Omega$
- Current output 0(4) ... 20mA
  - burden resistor max. 500 $\Omega$ , output voltage max. 10V
  - minimum burden resistor 100 $\Omega$  @  $T_u > 50^\circ\text{C}$ , 0 $\Omega$  @  $T_u < 50^\circ\text{C}$
- Voltage output: 0(2) ... 10V (option)
- Resolution: 10 bits

### Ambient temperature

(Ambient temperature of the actuator)

0°C to +60°C (standard)

Up to  $-15^\circ\text{C}$  with anti-condensate heater (option, consultation required)

### Protection class (IP code)

Protection class of the actuator

# 7 Operation



## Important information!

The actuator may not be put into operation unless the owner/lessor of the machine/system has proven that the system or machine into which it is to be installed is in compliance with all applicable EC directives.



## The actuator may not be put into service unless

- the hood is properly installed, and
- the screwed cable glands have been sealed.

## CAUTION

### Danger of burning at the actuator motor and at the actuator components!

The actuator motor may become hot during operation.

The valve may transfer very low or very high temperatures to the actuator, which depend on the ambient conditions and the temperature of the medium flowing through the valve.

- Do not operate the actuator without the hood in place.
- Where necessary, install safeguards on the actuator to prevent access to it.

## NOTE

### Continuous overloading or blocking of the actuator (e.g. by incorrectly set limit switches or foreign objects in the valves) will cause damage to the actuator.

- Properly set the limit switches (see section "5.4 Setting the position switches").
- Regularly inspect the valves for foreign objects.



Before

- switching the actuator **on** or **off**,
- changing any settings (e.g. rotational direction or swivel range) at the actuator,

check whether these actions could cause any dangerous movements within the machine/system or malfunctions of other assemblies!

**i****Important information!**

- Make manual settings on the actuator only at the output shaft end where required.
- Do not rotate the control shaft!
- As an alternative, you can also install auxiliary functions to the actuator to allow manual settings (see the section below).

## 7.1 Auxiliary functions (optional)

### 7.1.1 Handwheel

In case of a power failure the actuator can be adjusted using a handwheel.

**⚠ WARNING****Danger of injury from the handwheel rotating with the actuator!**

If the handwheel is moved while the actuator motor is running, there is a risk of injury such as the upper limbs being drawn in or caught by the rotating handwheel.

- Do not operate the handwheel unless the voltage supply has been switched off.

**NOTE****Risk of property damage caused by overrunning the limit switches or cancelling the adjustment of the potentiometer!**

- In manual mode, take care not to move the valve beyond the end positions set by the limit switches within the actuator.
- Mechanically limit the valve end position before moving the actuator in manual operation.

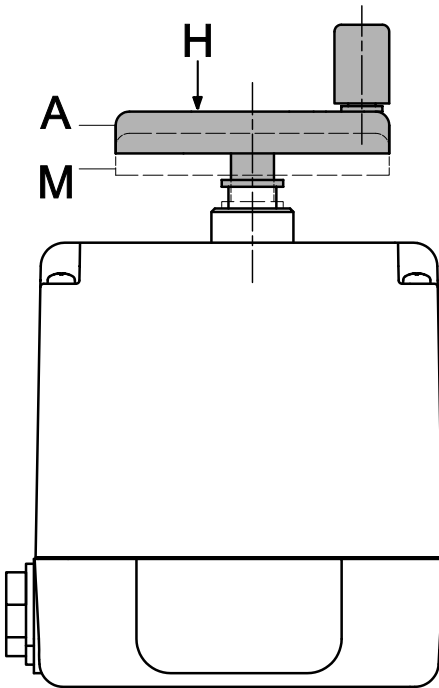

Fig. 7.1: Handwheel

1. Switch off the operating voltage of the actuator.
2. Push handwheel H onto the stop in position M and rotate it in the desired direction. Hold the handwheel in position M while rotating it. The control cams and the potentiometer shaft also rotate in manual operation. The adjusted positions of the control cams are maintained.
3. Release handwheel H as soon as the desired position is attained. The handwheel automatically returns to home position A.



**To be checked before re-commissioning:**

- Is the actuator in the permitted range limited by the limit switches?
- Is the potentiometer still properly adjusted?

## 7.1.2 Gearbox decoupling

Decoupling the gearbox is possible necessary for manually moving the output shaft during the adjustment process.

### **NOTE**

#### **Risk of property damage when the gearbox is decoupled!**

The valve must not be tensioned when the gearbox is decoupled. Decoupling cancels the holding torque of the motor, which may cause uncontrolled movements of the valve and damage the actuator gearbox.

### **NOTE**

#### **Risk of property damage caused by overrunning the limit switches or cancelling the adjustment of the potentiometer!**

- In manual mode, take care not to move the valve beyond the end positions set in the actuator.
- Mechanically limit the valve end position before moving the actuator in manual mode.
- Do not move the actuator electrically when it is decoupled!

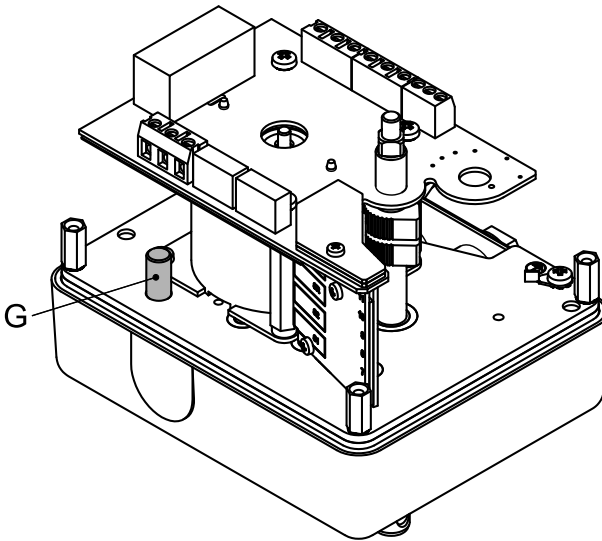

Fig. 7.2: Gearbox decoupling knob

1. Switch off the operating voltage of the actuator.
2. Remove any torque from the output shaft.
3. Push knob G onto the stop and hold it in this position.
  - This will interrupt the torque transmission from the motor to the output shaft.
  - It is not necessary to disconnect the output shaft or the valve shaft.
4. Turn the valve in the desired position. The control cams and the potentiometer shaft also rotate. The adjusted positions of the control cams are maintained.
5. Release adjusting knob G.
  - The knob automatically returns to the home position.
  - This will restore the torque transmission from the motor to the output shaft.
6. Restore the operating voltage of the actuator.



**To be checked before re-commissioning:**

- Is the actuator in the permitted range limited by the limit switches?
- Is the potentiometer still properly adjusted?



# 8 Maintenance and repair

## 8.1 Safety instructions

### DANGER

#### Warning of dangerous electrical voltage!

Working on live electrical devices poses a considerable risk of deadly or serious injuries!

If an actuator is open or operational, there is a risk of coming into contact with live parts (e.g. with a tool or another thin object).

- Work on electrical equipment may only be carried out by qualified and authorized electricians.
- Before attempting any work, disconnect the machine/system from the power supply and protect the machine/system against being switched on for the duration of the work.
- Adhere to the regulations of the VDE (German Association for Electrical, Electronic and Information Technologies) and to the regulations issued by the local utility company.



#### Before

- switching the actuator **on** or **off**,
- changing any settings (e.g. rotational direction or swivel range) at the actuator,

check whether these actions could cause any dangerous movements within the machine/system or malfunctions of other assemblies!



- Also observe the safety instructions in chapter “2 Safety”.
- Maintenance and inspection may only be carried out by qualified staff and in compliance with all safety instructions.
- Carry out all maintenance and inspection tasks within the time stipulated. Malfunctions caused by insufficient or improper maintenance may result in very high repair costs and long down-times. If the prescribed maintenance is grossly neglected within the warranty period, the operator himself must bear the resulting cost of recovery.

- 
- Inform the operating staff before starting any maintenance and inspection work.
  - Before carrying out any maintenance or inspection work, always disconnect the actuator from the power supply using the disconnecting device provided by the owner/lessor and protect the disconnecting device against being switched on unexpectedly.
  - Wait for the components to cool down to ambient temperature before starting the inspection or maintenance work.
  - Only use the specified greases or verifiably equivalent greases for lubricating the equipment.
  - Always wear the personal protective equipment prescribed during all inspection and maintenance work (see section “2.4 Personal protective equipment”).
  - Only use original spare parts when replacing components.
  - Maintain the minimum bend radius prescribed when laying cables.
  - Dispose all resources, greases and process materials that cannot be reused in an environmentally friendly manner.
  - Heavy components must always be lifted
    - by several persons or
    - using a crane or a similar lifting device,in accordance with the locally applicable industrial safety regulations.
  - Replace all protective covers previously removed after completing the inspection and maintenance work and before restoring operation. Make sure that all screws and nuts provided are installed again.
  - Make sure that all safeguards are installed and functional.

## 8.2 Maintenance work

### 8.2.1 Maintenance intervals

<i>Maintenance task</i>	<i>Maintenance interval</i>	<i>See section</i>
<b>Cleaning the actuator</b>	every 6 months <sup>1)</sup>	8.2.2
<b>Checking for leakage</b>	every 6 months	8.2.3
<b>Visual inspection</b>	once per year <sup>2)</sup>	8.2.4
<b>Electrical inspection</b>	every 4 years <sup>2) 3)</sup>	8.2.5

<sup>1)</sup> Or earlier if dirty

<sup>2)</sup> Initial inspection 6 months after start-up

<sup>3)</sup> Only if the electrical systems and resources are subjected to normal stress due to ambient temperatures, dust, humidity, etc. (see the guidelines of professional associations for occupational safety and health in force in the country of use); shorter intervals in case of higher stress.

**Actuator motor and gear ranges are lubricated with long-life grease and therefore require no maintenance if used as prescribed.**

#### Recommendations

- A trial run should be carried out every six months if the actuator is used infrequently to verify its proper function.
- The initial visual and the initial electrical inspections should be carried out 6 months after putting the actuator into service.

## 8.2.2 Cleaning the actuator

### NOTE

#### **Splash water may enter the actuator and destroy it!**

- Use a damp cloth for cleaning.
- **Never** clean the actuator with a high-pressure cleaner or with a water hose.

#### **Corrosive cleaning agents may damage the actuator components!**

- Do not use any strong, abrasive or flammable cleaning agents, diluting agents or similar fluids.
- A normal general-purpose cleaner is sufficient.



Clean the outside of the actuator with a damp cloth according to environmental influences – every 6 months at the latest, but earlier if dirt has accumulated.

## 8.2.3 Leak test

Check the inside of the actuator every 6 months for humidity.

1. Loosen the fastening screws of the hood.
2. Remove the hood from the actuator.
3. Inspect the inside of the actuator and the hood for signs of humidity.
4. After the inspection and possibly required rectification, reinstall the hood (see section “5.8 *Installing the hood*”).

Humidity inside the actuator may have the following causes:

- **Condensate**  
Condensate may be caused by varying ambient temperatures or temperature changes within the actuator (due to long motor run times).  
If this is the case, install an anti-condensate heater in the actuator (see section “5.7 *Anti-condensate heater (option)*”).
- **Damaged rubber sealing ring in the basic housing of the actuator**  
Return the actuator to Agromatic Regelungstechnik GmbH to have it repaired.
- **Leaking screwed cable glands/cable entries/filler plugs**  
Check whether the cable glands, cable entries or filler plugs are damaged and whether the connection lines used have an outer diameter suitable for the cable glands.
  - Replace any defective cable glands.
  - Only use connection lines with an outer diameter suitable for the cable glands (see section “2.3.3 *Protection classes IP65 (standard), IP66 (option)*”).
- **Damaged actuator housing or hood**
  - Replace the damaged hood (see section “8.3 *Spare parts*”).
  - If the actuator housing is damaged, return the actuator to Agromatic Regelungstechnik GmbH to have it repaired.
- **Heater does not work**
  - Have a qualified electrician inspect the heating resistor and the connection lines of the heater for correct function.
  - Replace the damaged heater if required (see section “8.3 *Spare parts*”).

## 8.2.4 Visual inspection

An initial visual inspection must be carried out 6 months after start-up, after which the inspection should be repeated at one-year intervals.

The following should be verified:

- Are the fastening screws between the part-turn actuator and the valve firmly tightened? Re-tighten screws if required.
- Are the cable glands, cable entries and filler plugs securely tightened and leakproof? Re-tighten or replace where required.
- Are the joining elements between the actuator and the valve (e.g. screw-type connections, connecting pins) in perfect condition? Re-tighten screws, replace pins, etc. where required.

## 8.2.5 Electrical inspection

### DANGER

#### Warning of dangerous electrical voltage!

Working on live electrical devices poses a considerable risk of deadly or serious injuries!

- Work on electrical equipment may only be carried out by qualified and authorized electricians.
- Before attempting any work, disconnect the machine/system from the power supply and protect the machine/system against being switched on for the duration of the work.
- Adhere to the regulations of the VDE (German Association for Electrical, Electronic and Information Technologies) and to the regulations issued by the local utility company.



- Have the responsible qualified electrician inspect the electrical equipment of the actuator for proper condition at least every 4 years and after every modification or repair.
- If the electrical equipment and the resources are subjected to increased stress due to ambient temperatures, dust, humidity, etc., the electrical inspection must be carried out at shorter intervals (see also the applicable guidelines of professional associations for occupational safety and health).
- Document the type and time of the inspection carried out in an inspection log.

## 8.3 Spare parts

Only use original spare parts, as only original spare parts guarantee trouble-free function of the device.

For ordering spare parts please contact:

**Agromatic Regelungstechnik GmbH**

Postfach 1162

33804 Oerlinghausen

Germany

Phone: +49 5202 9739-284

Fax: +49 5202 9739-25

E-mail: [vertrieb@agromatic.de](mailto:vertrieb@agromatic.de)

Web: [www.agromatic.de](http://www.agromatic.de)

Please quote the serial number when ordering spare parts. The serial number is specified on the nameplate inside the actuator.

### **i**

**Important information!**

Make sure to ***always*** quote the serial number on the ***nameplate*** located ***inside the actuator***.

Do **not** use the serial number indicated on the nameplate attached to the outside of the hood.

**The hoods of the actuators may not be swapped!**



# 9 Malfunctions

## 9.1 Safety instructions



### DANGER

#### Warning of dangerous electrical voltage!

Working on live electrical devices poses a considerable risk of deadly or serious injuries!

If an actuator is open or operational, there is a risk of coming into contact with live parts (e.g. with a tool or another thin object).

- Work on electrical equipment may only be carried out by qualified and authorized electricians.
- Before attempting any work, disconnect the machine/system from the power supply and protect the machine/system against being switched on for the duration of the work.
- Adhere to the regulations of the VDE (German Association for Electrical, Electronic and Information Technologies) and to the regulations issued by the local utility company.

## 9.2 General notes

Please contact our Service department if malfunctions occur with the actuator:

### **Agromatic Regelungstechnik GmbH**

Postfach 1162

33804 Oerlinghausen

Germany

Phone: +49 5202 9739-284

Fax: +49 5202 9739-25

E-mail: [vertrieb@agromatic.de](mailto:vertrieb@agromatic.de)



### Important information!

Make sure to **always** quote the serial number on the **nameplate** located **inside the actuator**.

Do **not** use the serial number indicated on the nameplate attached to the outside of the hood.

## 9.3 Repairs

Before returning an Agromatic actuator for repairs, request an RMA ("Return Material Authorization") number from the Agromatic Regelungstechnik GmbH Service department.

**Agromatic Regelungstechnik GmbH**

Postfach 1162

33804 Oerlinghausen

Germany

Phone: +49 5202 9739-284

Fax: +49 5202 9739-25

E-mail: [vertrieb@agromatic.de](mailto:vertrieb@agromatic.de)

Web: [www.agromatic.de](http://www.agromatic.de)

The provided RMA number must be attached to the actuator to facilitate fast and smooth execution of the repairs.

If a claim is raised, the original invoice must also be provided with the actuator.

### **i**

**Important information!**

Make sure to always quote the serial number on the ***nameplate*** located ***inside the actuator***.

Do **not** use the serial number indicated on the nameplate attached to the outside of the hood.

# 10 Decommissioning, disassembly

Only specifically trained technical staff may carry out the decommissioning and/or disposal of the product.

## DANGER

### Warning of dangerous electrical voltage!

Working on live electrical devices poses a considerable risk of deadly or serious injuries!

If an actuator is open or operational, there is a risk of coming into contact with live parts (e.g. with a tool or another thin object).

- Work on electrical equipment may only be carried out by qualified and authorized electricians.
- Before attempting any work, disconnect the machine/system from the power supply and protect the machine/system against being switched on for the duration of the work.
- Adhere to the regulations of the VDE (German Association for Electrical, Electronic and Information Technologies) and to the regulations issued by the local utility company.



## 10.1 Putting the actuator out of operation



Before switching off the actuator, check whether this may cause dangerous movements within the machine/system or malfunctions of other assemblies!

1. Switch off the actuator and all upstream and downstream system components.
2. Attach a danger sign with the warning “**Out of service!**” on the system main switch and/or the disconnecting device.
3. Have the power supply disconnected by a qualified electrician.

## 10.2 Dismantling and disposing of the actuator

When the actuator has reached its end of service life, it must be dismantled and disposed of in an environmentally friendly manner. The general, legal and otherwise binding regulations regarding the prevention of accidents and the protection of the environment in force in the country of use (e.g. the national regulations of the professional associations for occupational safety and health) must be adhered to.

### **WARNING**

**Incorrectly placed or improperly attached components can drop down and cause personal injuries.**

- Always wear industrial protective clothing, safety shoes and where required protective gloves when working on the equipment.
- Secure the components e.g. with ropes or the like against dropping down before dismantling the actuator.

### **NOTE**

**Risk of environmental damage or pollution due to incorrect disposal!**

Electrical scrap, electronic components, lubricants and other process materials must be treated as hazardous waste and may be disposed of only by approved specialists.

- Dispose of the actuator components, separated by material, in an environmentally friendly manner.  
Observe the environmental protection regulations in force in the country of use.
- Dispose of greases and oils according to the waste oil ordinance locally in force.
- Transfer the dismantled components to the recycling process:
  - scrap metals,
  - send plastic elements to recycling,
  - dispose of other components segregated by material type.

### **i**

#### **Important information!**

You may alternatively return the actuator to Agromatic Regelungstechnik GmbH for disposal.

# 11 Appendix

## 11.1 Certificates

The actuator complies with the following EC directives:

- Directive 2006/42/EC (“Machinery Directive”)
- Directive 2004/108/EC (“EMC Directive”)

On the following pages you will find translations of the German

- declaration of incorporation for a partly completed machine according to Annex II, part 1, section B of the directive 2006/42/EC for rotary and part-turn actuators
- declaration of conformity according to Directive 2004/108/EC
- statement relating to Directive 2011/65/EU (“RoHS Directive”).



## Declaration of Incorporation of Partly Completed Machinery

(Translation of the German Original)

according to the

**Directive 2006/42/EC ("Machinery Directive"), Annex II, Part 1, Section B**

We hereby declare as the solely responsible party that the product

General designation	electrical actuator (rotary/part-turn actuator)
Series	N, NL, NK and identical constructions
Type	N1 to N8, NL, NK and identical constructions
Serial no.	1340-85754-01001 and higher

to which this declaration refers, complies with the following relevant provisions of Annex I of the Directive 2006/42/EC as far as the directive applies to the scope of delivery:

1.1.2; 1.1.3; 1.1.5; 1.3.4; 1.4.1; 1.4.2.1; 1.5.1; 1.5.2; 1.5.4; 1.5.6; 1.5.8; 1.5.9; 1.5.11; 1.6.4; 1.7.3; 1.7.4

The following harmonized standard was applied:

DIN EN ISO 12100:2011-03 ("Safety of machinery")

The product is a partly completed machine according to article 2, letter g of the Directive 2006/42/EC. The technical documentation was issued in compliance with Annex VII of the directive. The original German version of the installation and operating manual is available. The documentation mentioned above will be submitted to the responsible individual authorities in response to a reasonable request.

Regarding the electrical hazards originating from a partly completed machine, the protective goals laid down in the Directive 2006/95/EC ("Low-voltage Directive") are adhered to in accordance with Annex I, no. 1.5.1 of the Directive 2006/42/EC. The following harmonized standard was applied in this respect:

DIN EN 61010-1: 2011-07

("Safety requirements for electrical equipment for measurement, control and laboratory use")

The partly completed machine may not be put into service unless the owner/operator of the system/machine has proven that the system or the machine, into which the partly completed machine is to be installed, is fully compliant with all the applicable EC directives.

Person authorized to compile the relevant technical documentation:

Agromatic Regelungstechnik GmbH  
 Department "Technische Dokumentation"  
 Stukenbrocker Weg 38  
 33813 Oerlinghausen, Germany

This declaration shall become void if modifications are made to the product which are not authorized by us or if the product is not installed or used according to its intended purpose.

Oerlinghausen, 09/27/2013



Dr. Christian Lutz, Geschäftsführer  
 (Managing Director)

Agromatic Regelungstechnik GmbH  
 Stukenbrocker Weg 38 • 33813 Oerlinghausen, Germany • Phone: +49 5202 9739-0 • Fax: +49 5202 9739-25  
 www.agromatic.de • info@agromatic.de

**EC Declaration of Conformity**  
(Translation of the German Original)  
for the purpose of the  
**Directive 2004/108/EC ("EMC Directive")**

We hereby declare as the solely responsible party, that the product

General designation	electrical actuator
Series	N, NL, NK, K, KA, V, VK and identical constructions
Type	N1 to N8, NL, NK, K 1506-7550, KA 1506-11050, V 1 to V 5, VK and identical constructions
Serial no.	1340-85754-01001 and higher

to which this declaration refers, complies with the requirements of the directive specified above. The following harmonized standards were applied:

- DIN EN 61000-6-2: 2006-03 (interference immunity)
- DIN EN 61000-6-3: 2011-09 (interference emissions)
- DIN EN 61000-3-2: 2010-03 (interference emissions)
- DIN EN 61000-3-3: 2009-06 (interference emissions)

The technical documentation according to Annex IV of Directive 2004/108/EC ("EMC Directive") have been issued. The original German version of the installation and operating manual is available. The documentation mentioned above will be submitted to the responsible individual authorities in response to a reasonable request.

The product is a partly completed machine according to article 2, letter g of the Directive 2006/42/EC ("Machinery Directive").

This declaration shall become void if modifications are made to the product which are not authorized by us or if the product is not installed or used according to its intended purpose.

Oerlinghausen, 09/27/2013

  
Dr. Christian Letz, Geschäftsführer  
(Managing Director)

Agromatic Regelungstechnik GmbH  
Stukenbrocker Weg 38 • 33813 Oerlinghausen, Germany • Phone: +49 5202 9739-0 • Fax +49 5202 9739-25  
www.agromatic.de • info@agromatic.de

# Agromatic®

Regelungstechnik GmbH

**Statement**  
regarding the  
**Directive 2011/65/EU (“RoHS Directive“)**

Agromatic actuators fall within the scope of article 2, section 4, letter c of Directive 2011/65/EU, due to the fact that the actuators are designed for installation in

- large-scale stationary industrial tools (article 2, section 4, letter d), or
- large-scale fixed installations (article 2, section 4, letter e), or
- means of transport for persons or goods (article 2, section 4, letter f)

to fulfill their function.

The terms “large-scale stationary industrial tools” and “large-scale fixed installation” are defined in article 3, no. 3 and article 3, no. 4 of the directive. These definitions clearly indicate that the scope of Directive 2011/65/EU does not apply to Agromatic actuators.

As a responsible organization, we nevertheless want to make our contribution to the protection of the environment. Agromatic Regelungstechnik GmbH shall therefore implement the requirements of the directive specified above as far as this is technically feasible – irrespective of the fact that the directive does not apply to Agromatic actuators.

Oerlinghausen, 09/27/2013



Dr. Christian Lutz, Geschäftsführer  
(Managing Director)

# 12 Index

Page numbers printed in bold indicate the section with the highest relevance.

## A

assembly **23**

## C

cam *see* control cam

cleaning 73, **74**

control cam **37**

- aluminum control cam **40**

- plastic control cam **38**

current output **46**

## D

Declaration of Conformity **85**

Declaration of Incorporation **84**

direction of rotation **31**

## H

handwheel **66**

hood **47**

## M

maintenance 14, **71**

maintenance intervals **73**

maintenance work **73**

## N

nameplate **19**

## P

position controller

- programming **58**

- reset **62**

- resetting **62**

potentiometer **44**, 46, 67, 69

## R

repairs **80**

resetting the position controller **62**

RoHS **86**

## S

schematic diagram

- alternating current **34**

- current output **46**

- ESR-NL **52**

- parallel operation **35**

- position controller **52**

- potentiometer **44**

- service switch **35**

Service department 79

spare parts **77**

storage 21, **22**

switches 33, 34, **36**, **37**, 38, 40

## T

technical data

- actuator **16**

- ESR-NL **64**

- position controller **64**

transmitter *see* current output

**Agromatic Regelungstechnik GmbH**

Postfach 1162  
33804 Oerlinghausen  
Deutschland

Phone: +49 5202 9739-284

Fax: +49 5202 9739-25

E-Mail: [vertrieb@agromatic.de](mailto:vertrieb@agromatic.de)

Web: [www.agromatic.de](http://www.agromatic.de)

***Agromatic***<sup>®</sup>