

MEMDOS MR

Motor-Driven Diaphragm Dosing Pump



EN

02

Operating Manual

Read this operating manual before start-up!
To be retained for future reference.

Table of Contents

1. General and Safety Instructions	3
2. General	7
2.1 Use for intended purpose.....	7
2.2 Structure of the dosing pump.....	7
3. Function	8
4. Dimensioned drawings	9
5. Technical data	11
5.1 Electric motor data.....	12
5.2 Technical data, ATE servomotor MEMDOS MR (optional).....	14
6. Delivery characteristic curves	16
7. Installation	18
7.1 General information.....	18
7.2 Installation location.....	19
7.3 Drain pipe.....	19
7.4 Electrical connection of the pump.....	19
7.5 Wiring diagrams for ATE servomotor for stroke length adjustment.....	20
7.6 Pressure control and safety valves.....	22
7.7 Injection nozzle installation.....	22
7.8 Installation example.....	23
8. Operation	24
8.1. Stroke length adjustment.....	24
Device revision	24
9. Start-up	25
9.1 Start-up of MEMDOS MR with ATE servomotor.....	25
10. Shutdown	26
10.1 Disposal of old equipment.....	26
11. Maintenance	27
11.1 Lubrication.....	27
11.2 Maintenance of the bearings.....	27
11.3 Maintenance of the ATE servomotor (optional).....	27
11.4 Diaphragm replacement.....	27
11.5 Manual adjustment of the ATE servomotor, Type AR30W.....	29
11.6 Valves.....	29
12. Explosion-proof dosing pumps (ATEX)	31
12.1 General.....	31
12.2 Special conditions.....	31
12.3 Dosing of flammable media.....	31
13. Troubleshooting	32
14. Spare parts	33
14.1 Spare parts sets.....	33
15. External vent (optional)	34
Index	35
Declaration of no objection	36
Warranty claim	37
EC Declaration of Conformity	38

1. General and Safety Instructions

1.1 General

This operating manual contains basic instructions to be followed during installation, operation and maintenance. It is therefore essential for the assembler and the relevant technical personnel/operating company to read this operating manual prior to installation and start-up. It must remain accessible at the place of installation of the system for reference at all times.

Besides the general safety instructions in this "Safety" section, the special safety instructions in the other sections are also to be followed.

1.2 Identification of safety instructions in this operating manual

Failure to follow the safety instructions in this operating manual may result in personal injury or damage to the environment and the system. Safety instructions are identified by the following symbols:

DANGER!

Indicates immediate danger.

Failure to follow this instruction will lead to death or extremely serious injuries.



WARNING!

Refers to a potentially hazardous situation. Failure to follow this instruction may lead to death or extremely serious injuries.

CAUTION!

Refers to a potentially hazardous situation. Failure to follow this instruction may lead to minor injuries or damage to property.

ATTENTION! or NOTICE!

Failure to follow these safety instructions may endanger the machine and its functions.

IMPORTANT!

This indicates additional information that makes work easier and ensures trouble-free operation.



Information attached directly to the dosing pump, such as

- cable markings
- markings for fluid connections

must be followed without fail and must remain fully legible at all times.

1.3 Personnel qualifications and training

The personnel employed for operation, maintenance, inspection, and installation must be suitably qualified for this work. The responsibilities, areas of competence and personnel supervision must be clearly defined by the operating company. Personnel who do not have the required know-how must be duly trained and instructed. If necessary, this can also be done by the manufacturer/supplier on behalf of the operating company. In addition, the operating company must ensure that the personnel are fully familiar with, and have understood the contents of this operating manual.

1.4 Important safety instructions

When installing and using this electrical device, basic safety precautions should always be followed, including the following:

ATTENTION!

Read and follow all instructions! Keep this operating manual for future reference!

WARNING!

To reduce the risk of injury, do not permit children to use this product unless they are closely supervised at all times.



**WARNING!**

Risk of electric shock. Connect the device only to a socket outlet with earthing contact protected by a ground fault circuit interrupter (GFCI). Consult a qualified electrician if you are uncertain whether the socket is protected by a GFCI.

Do not bury the cable. Fix the cable to minimise possible damage due to lawn mowers, hedge trimmers, and other equipment.

WARNING!

To reduce the risk of electric shock, replace the cable immediately if damaged.

WARNING!

To reduce the risk of electric shock, do not use an extension cable to connect the device to the power supply; use an appropriately located outlet socket.

1.5 Hazards due to failure to follow safety instructions

Failure to follow the safety instructions may endanger not only persons, but also the environment and the device. Failure to follow the safety instructions may invalidate any damage claims.

The following hazards in particular may result:

- Failure of major equipment functions
- Failure of required maintenance and repair methods.
- Danger to persons due to electrical, mechanical and chemical effects.
- Danger to the environment due to leakage of hazardous substances.

1.6 Safety-conscious working

The safety instructions contained in this operating manual must be observed. The operating company is responsible for ensuring compliance with local safety regulations. Faults that may affect safety must be repaired immediately.

1.7 Safety instructions for the operating company/operator

Leakages of dangerous substances (e.g. aggressive, toxic), for example due to a broken diaphragm, must be suitably drained away so that they do not cause danger to persons or the environment. Statutory regulations must be observed.

Dangers due to electric current must be prevented (for further details, refer to the VDE¹⁾ regulations and regulations of the local power supply companies).

¹⁾ German Association for Electrical, Electronic & Information Technologies

Separate regulations must be observed if the MEMDOS MR is operated in areas with a potentially explosive atmosphere. The operating company must determine the explosion hazard (area classification) and select the appropriate equipment. Further information can be found in paragraph 7.1 (Installation), paragraph 7.4 (Electrical connection) and section 12 (Explosion-proof dosing pumps).

1.8 Safety instructions for inspection, maintenance and installation work

The operating company must ensure that all maintenance, inspection and installation work is carried out by authorised and duly qualified personnel, who have read and understood this operating manual.

Any work on the machine must only be carried out after it has been brought to a complete stop. Always follow the procedure specified in the operating manual for shutting down the dosing pump/system.

Dosing pumps or systems which convey hazardous media must be decontaminated.

All safety and protective equipment must be reattached and activated immediately after the work has been completed.

CAUTION!

Particular care must be taken when repairing the MEMDOS MR if used in areas with a potentially explosive atmosphere. Due to the risk of sparking, care must be taken to prevent metal parts or tools knocking against one another. When repairing, it is better to move the dosing pump out of the area with a potentially explosive atmosphere.

The instructions given in section 7.2 "Installation location" and section 9. "Start-up" must be observed before start-up.



1.9 Unauthorised modification and production of spare parts

The device may only be modified or converted in consultation with the manufacturer. Use only the manufacturer's spare parts and accessories. Otherwise the warranty is invalidated.

1.10 Inadmissible operating practices

Any methods of operation other than those described in Section 2 "Proper use" are not permitted and will invalidate any manufacturer liability under the warranty.

1.11 Dosing of chemicals

CAUTION!

When working on dosing systems, the local accident prevention regulations must be observed and the specified personal protective equipment must be worn. The following standard protective clothing is recommended, depending on the hazardousness of the metered medium:



Protective clothing



Protective gloves



Protective goggles

It is recommended that all persons responsible for the installation and maintenance of piping systems, hoses and accessories wear this protective clothing.

Before working on the dosing pump and system, disconnect it from the mains power supply and prevent it from being switched on.

CAUTION!

Any chemical still present in the dosing head may spray out when the voltage supply is reconnected. This may lead to chemical or other burns to the face and hands. Dosing lines must always be connected before switching on again.

The chemical resistance of the construction materials in the pump must be verified before dosing aggressive media!

The pump dosing head and the system connections and lines may be under pressure. Working on the dosing system requires special safety precautions and is allowed only for suitably trained personnel:

CAUTION!

Chemical may spray out. This may lead to chemical or other burns. Always release the pressure before starting work on the dosing pump.

Before working on the dosing head, valves and connections, flush the dosing pump with a harmless medium (water in most cases), to avoid unintentional contact with the metered medium.

WARNING!

Never look into the open end of a clogged line or valve. Chemicals may emerge unexpectedly and cause chemical or other burns to face and hands.

Before start-up, all screw connections must be inspected for correct tightness and leak-tightness, and must be re-tightened using an appropriate tool if necessary.



**CAUTION!**

If connections at the dosing head are loosened during operation, for venting or other reasons, leaking chemicals must be removed properly. This is the only way to avoid health hazards due to chemicals, and chemical corrosion of the dosing pump. Leaking chemicals may also damage the diaphragm at its mounting edge.

ATTENTION!

If changing the chemical, check the materials in the pump and other system parts for chemical resistance. If there is a danger of chemical reaction between the different media, clean thoroughly beforehand.

**IMPORTANT!**

To operate the pump, mount the fan cowl in order to ensure sufficient cooling of the motor.

The protection class of the control unit is only ensured if the connection ports are protected by caps or the standard connectors are inserted.

**WARNING!****Lethal voltage!**

Take particular care when carrying out adjustment work on the inside of the ATE servomotor (optional for MEMDOS MR). Connections and internal limit switches might be live. Additional limit switches in the ATE servomotor may be under voltage (live) even when the auxiliary voltage is switched off. After installing the ATE servomotor or before start-up, re-attach the cover.

1.12 Transportation

No special devices are required for transportation of the dosing pumps. However, it is advisable to choose a transport method appropriate for the weight of the dosing pumps (e.g. transport trolley). If transporting with the oil drained, the dosing pump should preferably be placed in the horizontal position. Otherwise, stability must be ensured by screwing it onto the transport frame.

1.13 Scope of delivery**IMPORTANT!**

Carefully unpack the dosing pump and any accompanying accessories ordered, so that small parts are not left inside the packaging. Compare the delivery content with the delivery note immediately. If there are any discrepancies, determine the cause.

The following are part of the scope of delivery:

- Dosing pump MEMDOS MR
- Suction and discharge side connections
- Gear oil
- Operating Manual
- ATE servomotor (optional)
- Separate fan (optional)

2. General

2.1 Use for intended purpose

The device is intended for the following purpose only: the conveying and dosing of chemicals.

Operating safety is guaranteed only if the device is used for its intended purpose. Use for any other purpose is not permitted and will invalidate any liability under the warranty. The operating conditions described in section 5 "Technical Data" must be observed!

2.2 Structure of the dosing pump

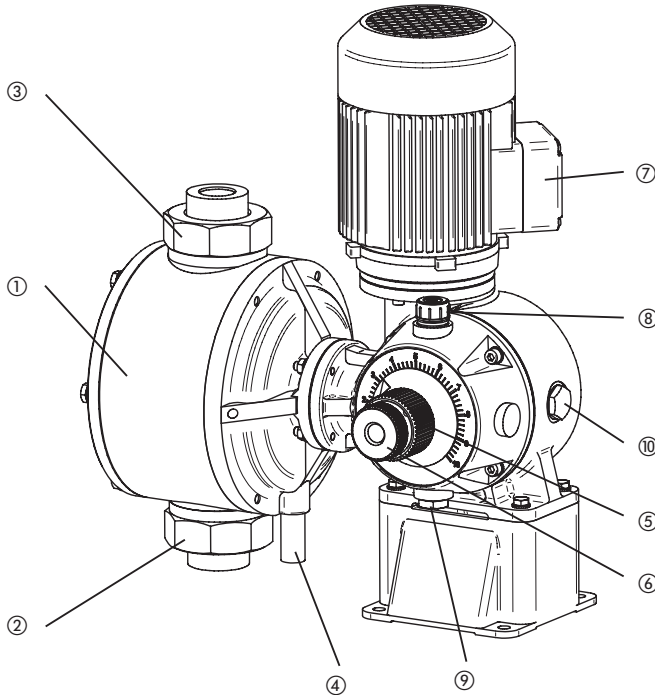

- ① Dosing head
- ② Suction side valve
- ③ Discharge side valve
- ④ Drain socket
- ⑤ Stroke length adjustment
- ⑥ Stroke length adjustment lock
- ⑦ Motor terminal box (MEMDOS MR voltage supply)
- ⑧ Oil inlet
- ⑨ Oil outlet
- ⑩ Oil level glass

3. Function

Motor-driven diaphragm dosing pumps of the MEMDOS series are used in industry in the process engineering sector, and in water treatment and wastewater processing.

The MEMDOS is available with one (as MEMDOS MR) or with two dosing heads (as MEMDOS ZMR). If not otherwise pointed out, all specifications of the MEMDOS MR are also applicable for the MEMDOS ZMR.

MEMDOS MR

The MEMDOS MR is used when no control is required for constant dosing. For this the voltage supply is connected directly to the terminal box of the motor. To adapt the dosing capacity, either the stroke length can be adjusted manually from 0 ... 100%, or the motor speed is controlled by means of a separate frequency converter. The MEMDOS MR is optionally available with electrical remote adjustment of the stroke length (ATE).

The MEMDOS MR can be operated in Zone 1 hazardous areas if the corresponding drive is taken into consideration. Further information can be found in section 12.

Principle of operation

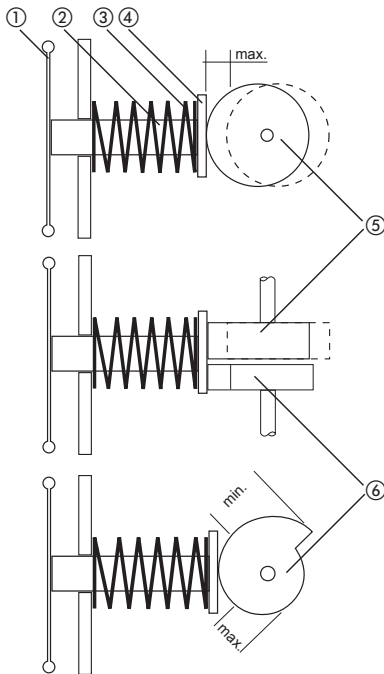

- ① Diaphragm
- ② Diaphragm rod
- ③ Return spring for suction stroke
- ④ Tappet plate
- ⑤ Drive eccentric
- ⑥ Stroke limit eccentric

Like the roller bearings, the worm gear set of the single-speed gear runs in an oil bath. Dosing takes place when movement of the drive eccentric ⑤ causes movement of the diaphragm rod ②. The suction stroke is produced by the return movement due to spring force. Stroke length is adjusted by limiting the tappet return movement using a manually adjustable eccentric disc as the end stop (stroke limiting eccentric ⑥). The adjustment range is from 0 to 100%.

4. Dimensioned drawings

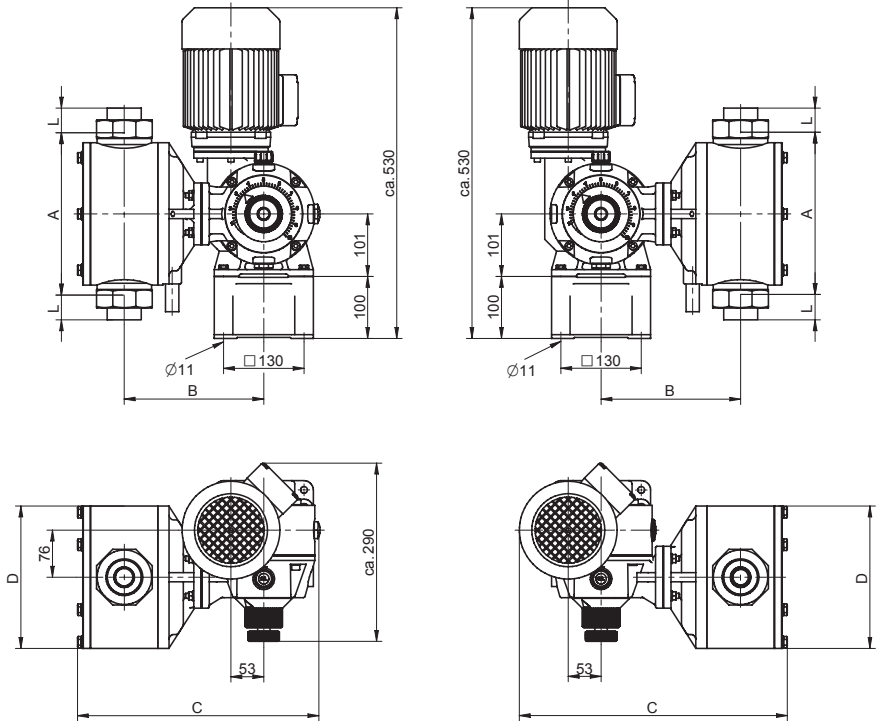

Dimensioned drawing MEMDOS MR 50 ... 980

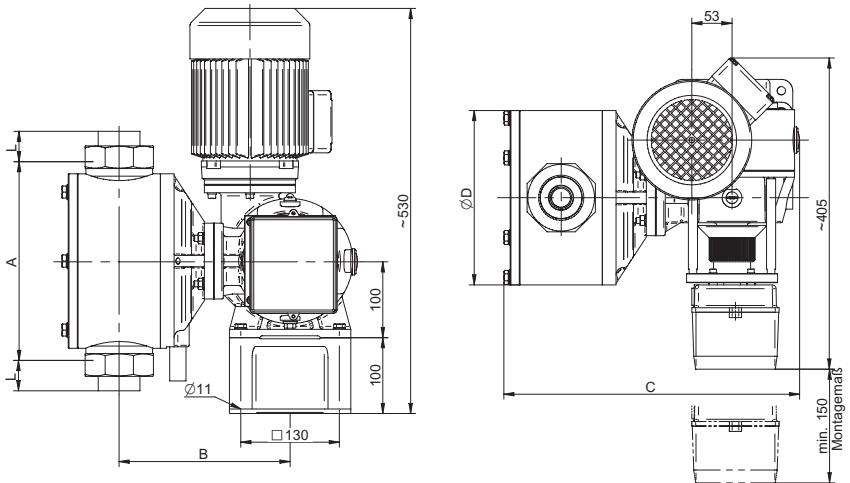

Dimensioned drawing MEMDOS MR 50 ... 980 ATE

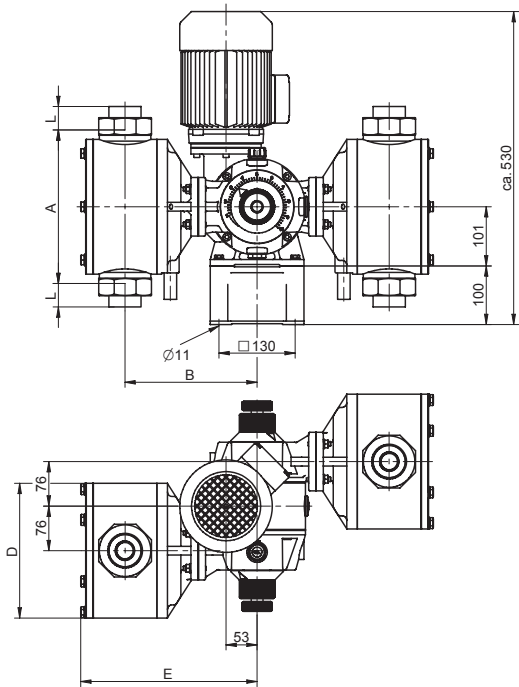

Dimensioned drawing MEMDOS ZMR 50 ... 980

MEMDOS	A	B	C	D	E
50	272	201	325	Ø 152	228
75	272	201		Ø 152	228
115	272	201		Ø 152	228
140	272	201		Ø 152	228
210	272	201		Ø 152	228
290	296	201		170	225
400	265	225	390	Ø 230	300
600	265	225		Ø 230	300
980	265	225		Ø 230	300

MEMDOS	Valves	Connection	DN	Line	L		
ZMR 50 ... 290	G 1 1/4	Pipe bonded connection	8	Pipe Ø 12	22		
			10	Pipe Ø 16			
		Pipe thread connection	10	Pipe G 3/8			
			15	Pipe G 1/2			
MR 400 ... 900 ZMR 400 ... 900	68.5	Pipe bonded connection	25	Pipe Ø 32	40		
			32	Pipe Ø 40	44		
		Pipe thread connection	20	Pipe G 3/4	40		
			25	Pipe G 1			
		Flange	25	Pipe bonded connection with thread	25	Pipe G 1 1/4	60
						Pipe Ø 32	75

All dimensions in mm

5. Technical data

MEMDOS MR	Size	400	600	980
Delivery rate at max. pressure ¹⁾	l/h	440	640	990
Stroke volume	ml/stroke	165		
Max. pressure	bar	5		4
Stroke frequency ¹⁾	rpm	47	70	101
Diaphragm ø	mm	185		
Stroke length	mm	13		
Suction lift	mbar	200		
Max. supply pressure (Σ static and dynamic)	mbar	500		
max. ambient temperature	°C	45		
max. temperature of the medium	°C	40 (for PVC dosing head) 60 (for PP and stainless steel dosing head, for short periods 80)		
Min. temperature of the medium	°C	0		
Power output	W	550		750
Weight plastic	kg	38		
Weight stainless steel	kg	48		

Duplex dosing pumps with equal dosing heads

MEMDOS ZMR	Size	50/50	75/75	115/115	140/140	210/210	290/290	400/400	600/600	980/980	
Delivery rate at max. pressure ¹⁾	l/h	50/50	90/90	135/135	160/160	240/240	290/290	440/440	640/640	990/990	
Stroke volume	ml/stroke	20		37		48	165				
Max. pressure	bar	10						5		4	
Stroke frequency	rpm	47	70	101	70	101	47	70	101		
Diaphragm ø	mm	90		120		150	185				
Stroke length	mm	10						13			
Suction lift	mbar	700		600		400	200				
Max. supply pressure	mbar	500									
max. ambient temperature	°C	45									
max. temperature of the medium	°C	40 (for PVC dosing head) 60 (for PP and stainless steel dosing head, for short periods 80)									
Min. temperature of the medium	°C	0									
Power output	W	750									
Weight plastic	kg	38				40	50				
Weight stainless steel	kg	48				53	60				

1) For 60 Hz operation, values are increased by a factor of 1.2.

Duplex dosing pumps with different dosing heads

MEMDOS ZMR	Size	50/ 400	75/ 140	75/ 600	115/ 210	115/ 290	115/ 980	140/ 600	210/ 290	210/ 980	290/ 980
Delivery rate at max. pressure	l/h	55/ 440	90/ 160	90/ 640	135/ 240	135/ 290	135/ 990	160/ 640	240/ 290	240/ 990	290/ 990
Stroke volume	ml/ stroke	20/ 165	20/ 37	20/ 165	20/ 37	20/ 48	20/ 165	37/ 165	37/ 48	37/ 165	48/ 165
Max. pressure	bar	10/ 5	10/ 10	10/5	10/10		10/4	10/5	10/ 10	10/4	
Stroke frequency	rpm	47	70		101			70	101		
Diaphragm ø	mm	90/ 185	90/ 120	90/ 185	90/ 120	90/ 150	90/ 185	120/ 185	120/ 150	120/ 185	150/ 185
Stroke length	mm	10/13	10/10	10/13	10/10		10/13		10/10	10/13	
Suction lift	mbar	700/ 200	700	700/ 200	700/ 600	700/ 400	700/ 200		600/ 400	600/ 200	400/ 200
Max. supply pressure	mbar	500									
max. ambient temperature	°C	45									
max. temperature of the medium	°C	40 (for PVC dosing head) 60 (for PP and stainless steel dosing head, for short periods 80 °)									
Min. temperature of the medium	°C	0									
Power output	W	750									
Weight plastic	kg	49	38	49	38	40	41		40	49	
Weight stainless steel	kg	55	48	55	48	43	55		50	55	

5.1 Electric motor data

MEMDOS MR				
Standard motor, type		AF 80 /4A-11	AF 80 /4B-11	AF 80 /4B-11
Part No.		78629	78903	78982
Speed	rpm	1390		1400
Voltage	V AC	230 / 400		
Nominal current	A	2.6 / 1.55		3.5 / 2.0
Power output	kW	0.55		0.75
Frequency	Hz	50		
Protection class		IP 55		
ISO class		F		
PTC thermistor		-		Yes

Explosion-proof motors for MEMDOS MR

MEMDOS MR					
Type		77139	79085	79119	79059
Explosion protection		increased safety EExellT3		EXdellCT4 pressure-resistant enclosure	
Speed]	rpm	1370		1380	1400
Voltage	V AC	230/400			
Nominal current	A	2.6/1.55	3.5/2.0	2.7/1.6	3.5/2.0
Power output	kW	0.55	0.75	0.55	0.75
Frequency	Hz	50	50	50	50
Protection class		IP 55			
ISO class		F			
PTC thermistor		optional			

5.2 Technical data, ATE servomotor MEMDOS MR (optional)

Type		AR 30W23	AR 30W23S
Part No.		78747	78518
Design		Reversible alternating current motor with self-locking step-down gear. Connections led out via cables (900 mm). Angle of rotation limited by two internal limit switches.	
Use		For controllers with switching output (3-point step control)	For controllers with constant output 0/2 ... 10 V or 0/4 ... 20 mA (switchable).
Voltage		230 V AC \pm 15 %, 50/60 Hz	24 V AC \pm 20 %, 50/60 Hz
Power consumption		2 W	7 W
Torque		15 Nm	
Actuating time	50 Hz	360 s	
	60 Hz	300 s	
Regulation bevel		270° = 0 ... 100 %	
Protection class		IP 55 (EN 60529)	
Ambient temperature		-20 ... +60 °C	
Weight		1.5 kg	2.0 kg
Inputs			
Control		3-point control	0 ... 10 V DC
			0 ... 20 mA
Input resistance at 0 ... 10 V DC		100 k Ω	
Load limit at 0 ... 10 V DC		max. 0.5 A	
Working resistance at 0 ... 20 mA		500 Ω	
Outputs			
Position feedback		Potentiometer 0.5 W, 0 ... 1 k Ω = 0 ... 100 %	0 ... 620 mV or 0 ... 10 V = 0 ... 100 %
End position feedback		Internal limit switch for the angle of rotation limitation	
Potential-free end position feedback		max. 250 V AC, 1 A	

Servomotor		WAN 1	WAN 1 S
Part No.		78529	78579
Design		Reversible alternating current motor with self-locking step-down gear	
Use		For controllers with switching output (3-point step control)	For controllers with constant output 0/4 ... 20 mA
Torque		15 Nm	
Voltage		230 V AC +/-10 %, 50/60 Hz, other voltages on request	
Power consumption		approx. 11.5 W	
Actuating time	50 Hz	360 s	
	60 Hz	300 s	
Regulation bevel		270° = 0 ... 100%	
Protection class		IP 54 acc. DIN 40050	
Ambient temperature		max. 60 °C	
Weight		2.5 kg	3.0 kg
Outputs			
Position feedback signal for remote display		Potentiometer 0.5 W 0 ... 1 k Ω = 0 ... 100 %	0/4 ... 20 mA (optional)
Option: 2 potentiometers		0 ... 1 k Ω 0.5 W	
Option: 2 limit switches		max. 250 V 1 A	

6. Delivery characteristic curves

The delivery characteristic curves refer to water at 20 °C (68 °F) and a suction lift of 0.5 m. The medium (density and viscosity) and temperature cause the delivery rate to change. Dosing pumps must therefore be gauged in litres for the application. At 60 Hz operation, values are increased by a factor of 1.2.

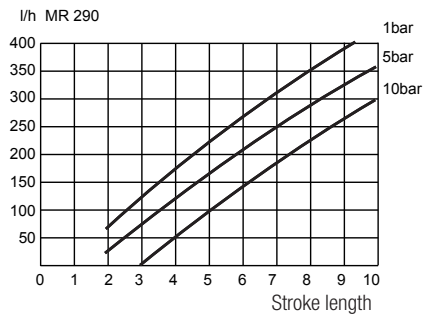
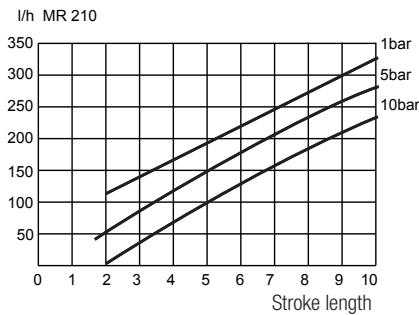
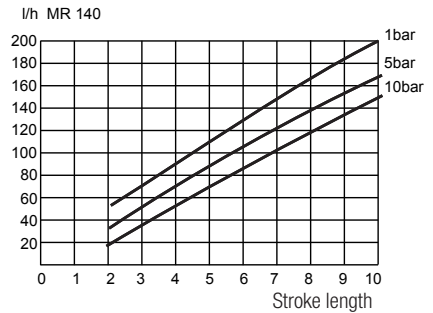
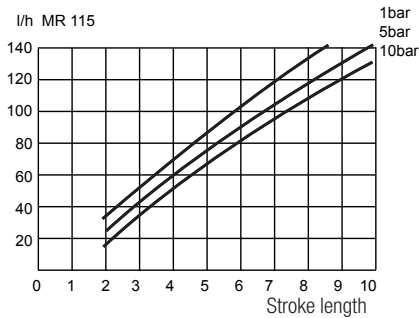
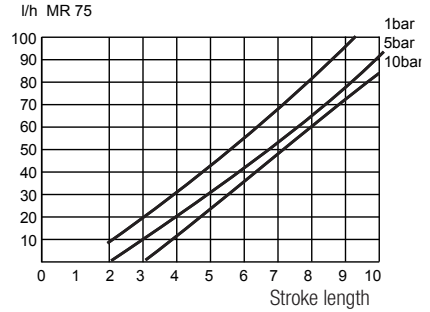
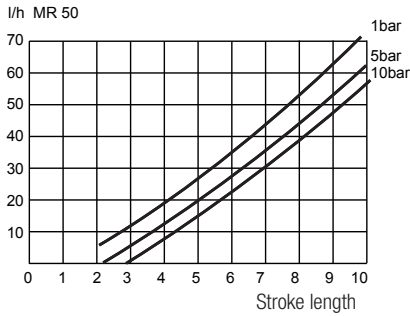

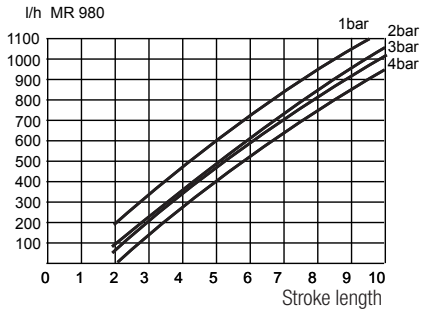
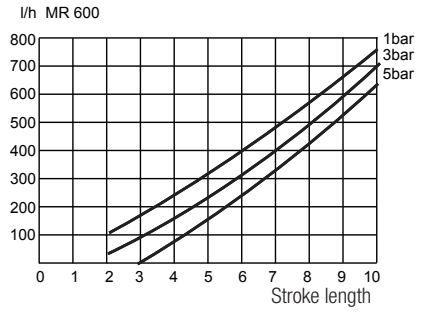
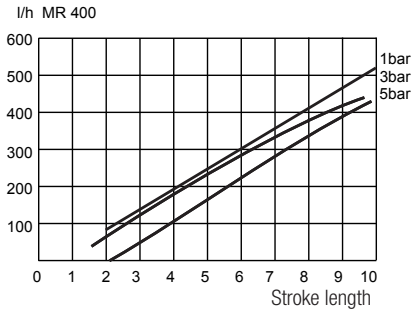

7. Installation

7.1 General information

Local rules and regulations must be taken into account when selecting a dosing pump for designing a system, and for installation and operation. This applies to the selection of the appropriate materials for the dosing pump, the handling of chemicals, and electrical installation.

Before installing the pump in areas with a potentially explosive atmosphere, the dosing pump must be checked to ensure that it meets the minimum requirements set by the applicable explosion protection regulations. For this purpose, the data on the dosing pump rating plate must be compared with the local requirements.

The technical specifications of the dosing pump (section 5) must also be taken into consideration, and the system designed accordingly (e.g. pressure loss for pipe dimensions i.e. nominal diameter and length).

The designer and operating company are responsible for ensuring that the entire system, including the dosing pump, is designed in such a way that neither system equipment nor buildings are damaged in the case of chemical leakage due to the failure of wearing parts (e.g. diaphragm rupture) or burst hoses. If the chemical system represents a potential source of danger, the installation must be designed in such a way that no unreasonable consequential damage occurs, even if the dosing pump fails. We therefore recommend installing leakage monitors and collecting pans.

The drain socket of the dosing head must be visible so that a diaphragm rupture can be detected. Drainage should be able to flow freely downward through the drain pipe.

To increase dosing accuracy and ensure functional reliability, we recommend installing additional valves and accessories. These include pressure control valves, pressure relief valves, leakage monitors and low level indicators, as shown in the installation examples.

Always use appropriate tools for the installation of plastic connection parts. To avoid damage, never apply excessive force.

IMPORTANT!

Plastic parts (especially PVC parts) can be tightened and loosened more easily by applying lubricant (e.g. silicone grease) to the thread beforehand.

To prevent seizing, threaded stainless steel parts (e.g. dosing head and valves) must be lubricated before being assembled (e.g. with PTFE spray).

ATTENTION!

Check the lubricant for compatibility with the chemical.

7.1.1 Installation of MEMDOS MR with ATE servomotor

The ATE servomotor is connected to the dosing pump and adjusted at the factory. When installing, sufficient installation space of at least 150 mm must be provided in order to allow later maintenance.

The electrical connection of the ATE servomotor must be made according to local regulations and may only be carried out by qualified technical personnel. The wiring diagrams (Section 7.5) show the two basic connection variants.

Cable type and cross-section must be chosen according to the motor data.

The cable passage through the housing must be made professionally. We recommend using gland connections with strain-relief clamp. The required protection class must be ensured by professional-standard installation of the electrical connections.



ATTENTION!

Note that the ATE servomotor can only be actuated when the main drive motor of the dosing pump is running. This means that the ATE servomotor must be locked electrically. Otherwise, the adjusting eccentric will suffer excessive wear, or be destroyed.



7.2 Installation location

The installation location of the dosing pump must be easily accessible by operating and service personnel.

ATTENTION!

Ambient temperatures above 40 °C are not permitted. Radiant heat from apparatus and heat exchangers must be shielded so that heat from the dosing pump can be dissipated sufficiently. Avoid exposure to direct sunlight. If the dosing pump is installed outside, provide a roof to protect it from the effects of weather.

Install the pump so that the suction and discharge valves are in vertical position. To ensure stability, the dosing pump must be screwed onto an appropriate surface. The system piping must not exert any force on the connections and valves of the dosing pump. To avoid dosing errors at the end of the process, the dosing pump must be locked electrically and hydraulically.

7.3 Drain pipe

ATTENTION!

Released gases can cause irreparable damage to the gearing in the dosing pump.

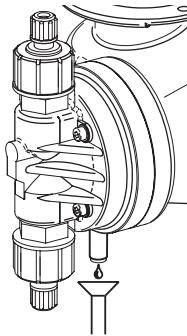

Drainage or leakage from the separating chamber must be allowed to flow downward to the collecting pan. The drain pipe must never lead directly back to the medium through the tank cover, otherwise released gases may get into the pump gearbox. The drain pipe should only lead downward to a gas-free collecting tank or downward to a collecting funnel, leaving a sufficient gap from the end of the pipe. Leakage can then be returned through the funnel and through the tank cover. This makes it easier to detect any leakages at the gap to the collecting funnel.

ATTENTION!

If a leakage monitor is installed in an area with a potentially explosive atmosphere, the electrical connection must be intrinsically safe. The drive motor must be electrically interlocked to prevent additional medium escaping if a leak occurs.



7.4 Electrical connection of the pump

The electrical connection of the dosing pump must be made according to local rules and regulations and may only be carried out by qualified technical personnel. Cable type and cross-section of the supply lines must be chosen according to the motor data. The cable passage to the motor terminal box must be made professionally. We recommend using gland connections with strain-relief clamp. The required protection class must be ensured by professional-standard installation of the electrical connections.

ATTENTION!

Dosing pumps with explosion-proof motors must be installed and commissioned by specialists qualified to work with equipment intended for use in potentially explosive atmospheres. The user is responsible for ensuring that explosion-proof motors are connected correctly. Both the motor and dosing pump must be grounded to prevent electrostatic discharges.



NOTE!

The dosing pump must be plugged into a grounded power outlet.



NOTE!

Signal cables must not be laid parallel to high-voltage current lines or mains cables. Lay supply and signal lines in separate channels. An angle of 90° is required at line crossings. If signal lines are longer than 2 m, shielded cables must be used.

ATTENTION!

To avoid premature wear of the gear, always ensure the correct rotation direction of the motor: counter-clockwise (to the left), looking toward the fan wheel.

7.4.1 Drive motor connection

IMPORTANT!

Note the data on the motor rating plate



Connection	MEMDOS	Phases	Note
	MR 50 ... 980	3~	Y-connection (Standard)
			Delta connection

MEMDOS MR three-phase motors

Electrical connection data

MEMDOS	Voltage	Frequency	Power output	Current
	V	Hz	kW	A
MR 50 ... 980	400/230	50	0.55	1,50/2,60
	400/230			1,25/2,20
	400/254	60		1,25/2,20
	400/230	50		0.75
	400/230	60	1,75/3,05	
	400/254		1,70/3,10	

7.5 Wiring diagrams for ATE servomotor for stroke length adjustment

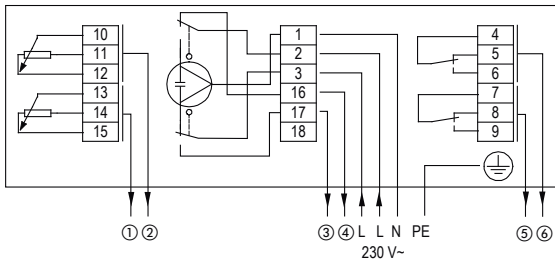

Terminal	Item	Function	Wire	Assignments
1		3-point control, Voltage 230 V~, 50/60 Hz	N	
2			L	Reduce
3			L	Increase
4, 5, 6	⑤	Isolated end position feedback, max. 250 V~, 1 A (optional)		
7, 8, 9	⑥			
10, 11, 12	①	Position feedback, 0 ... 1 kΩ		
13, 14, 15	②	Position feedback, 0 ... 1 kΩ (optional)		
16	③	End position feedback	0 %	
17	④		100 %	
18	-			

Fig. 7.1 Wiring and terminal diagrams, ATE servomotor Sauter AR 30W23

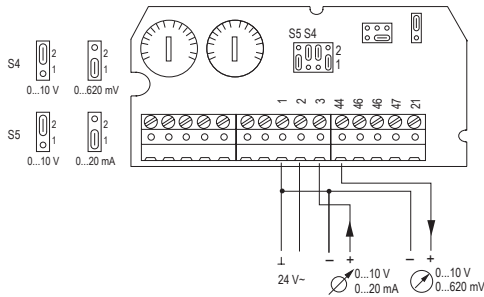
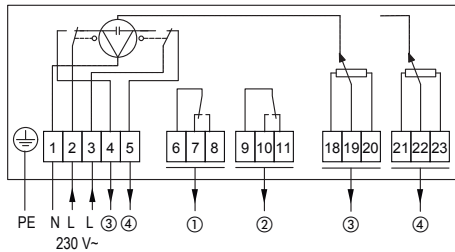
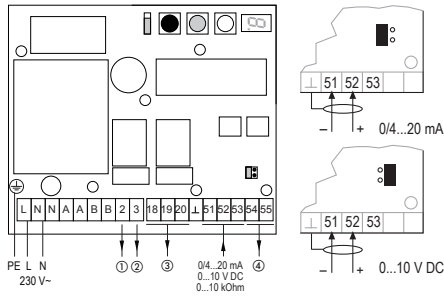

Fig. 7.2 Wiring and terminal diagrams, ATE servomotor Sauter AR 30W23S



Terminal	Item	Function	Wire	Assignments
1		3-point control, Voltage 230 V~, 50/60 Hz	N	
2			L	Reduce
3			L	Increase
4	③	End position feedback	0 %	
5	④		100 %	
6, 7, 8	①	Isolated end position feedback, max. 250 V~, 1 A (optional)		
9, 10, 11	②			
18, 19, 20	③	Position feedback, 0 ... 1 kΩ		
21, 22, 23	④	Position feedback, 0 ... 1 kΩ (optional)		

Fig. 7.3 Wiring and terminal diagrams, ATE servomotor WAN1



Terminal	Item	Function	Assignments
2	①	End position feedback	0 %
3	②		100 %
18, 19, 20	③	Position feedback, 0 ... 1 kΩ	
54 (-)	④	Position feedback, 0 ... 20 mA	
55 (+)			

Fig. 7.4 Wiring and terminal diagrams, ATE servomotor WAN1S

7.6 Pressure control and safety valves

Pressure control valves are used to optimise the dosing process. They are used:

- to increase the dosing accuracy in the case of fluctuating backpressure.
- when the dosing lines are long, in order to prevent excess delivery, since the accelerated medium continues moving due to its own inertia even after the delivery stroke has ended.
- to prevent siphoning, if the supply pressure is higher than system pressure.

Pressure relief and safety valves are used for overload protection of the dosing pump and the associated valves and lines. They prevent inadmissible pressure rises in the delivery side system of the dosing pump; for example, if shutoff valves close while the pump is running, or if the injection nozzle is clogged.

The PENTABLOC is a combination valve and performs the functions of a pressure control valve and a safety valve. It also integrates functions such as anti-siphoning, pressure relief and dosing control.

7.7 Injection nozzle installation

Injection nozzles are used to inject the metered medium into the main flow, while at the same time acting as non-return valve. The injection nozzle is usually mounted from the top into the main line. Mounting from below is recommended only for media that have a tendency to crystallise, in order to prevent air bubbles from being trapped in.

For media that tend to contaminate the injection nozzle, we recommend installing an injection nozzle that can be shut off and removed for maintenance purposes.

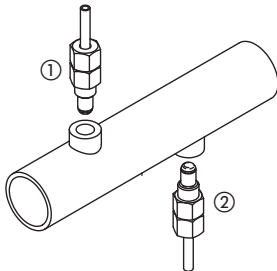

① Injection nozzle mounted from above, ② Injection nozzle mounted from below (for media that tend to crystallise)

7.8 Installation example

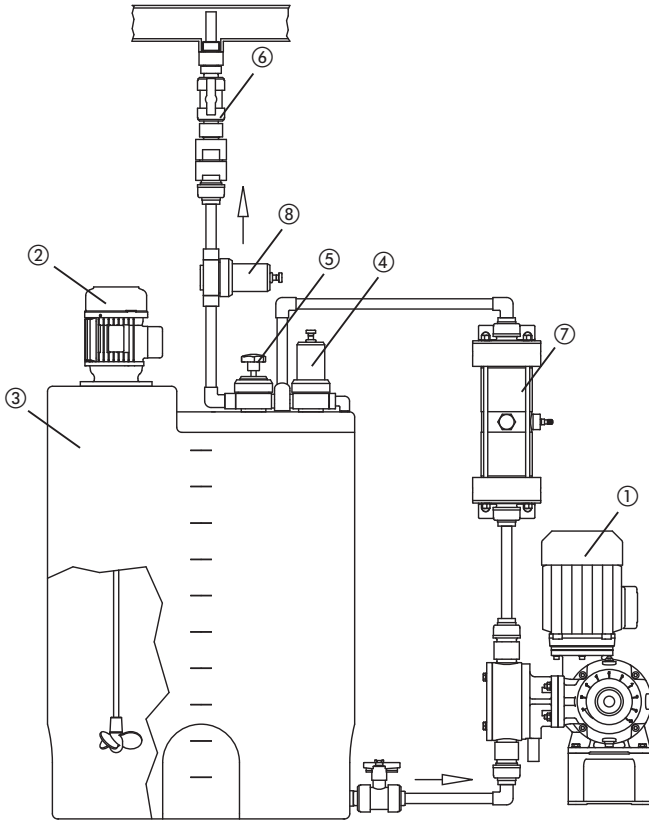

- ① MEMDOS MR
- ② Electrical agitator
- ③ Tank
- ④ Pressure relief valve
- ⑤ Diaphragm shutoff valve
- ⑥ Injection nozzle
- ⑦ Pulsation damper
- ⑧ Pressure control valve

8. Operation

8.1. Stroke length adjustment



ATTENTION!

The stroke length should not be adjusted while the dosing pump is stopped!

Proceed as follows to adjust the stroke length:

1. Turn the mounting screw on the adjusting knob counterclockwise (to the left) to loosen it.
2. Set the stroke length to the required value according to the delivery characteristic curves (section 6).
3. Retighten the mounting screw without changing the stroke length setting.

Device revision

This operating manual applies to the following devices:

Device	Revision
MEMDOS MR	8/2001

It contains all the technical information required for installation, start-up and maintenance. Should you have any questions or require further information regarding this operating manual, please contact the manufacturer or their official national representative.

9. Start-up

CAUTION!

The personal protective equipment specified by the applicable accident prevention regulations must be worn whenever working on the dosing pump/system!



Protective clothing



Protective gloves



Protective goggles

1. All the work described under "Installation" (Section 7) must be carried out before starting the dosing pump. The safety instructions (Section 1) must also be observed.
2. Fill the dosing pump with the oil supplied. For oil grade and quantity, see section 11.1.
3. The MEMDOS MR dosing pump is switched on by an externally installed control system.
4. The manual capacity adjustment should be set to maximum stroke for better priming. During the initial priming, there should be no backpressure. For this purpose, we recommend installing a relief valve on the discharge side of the dosing pump.
5. If a priming aid has been installed, this must be filled with chemical first. If the dosing pump does not prime, switch off the dosing pump, unscrew the discharge valve and fill the dosing head with fluid. If non-hazardous, the medium itself can be used; otherwise use a neutral medium that will not disturb the process. (In many cases, water can be used.)

WARNING!

Chemical may spray out. This may lead to chemical or other burns. Ensure that the discharge line is depressurised before disconnecting.

Then reinstall the discharge valve, switch on the dosing pump and allow it to prime. (A priming aid is recommended. See example installations.)



6. If there is a vent valve integrated in the dosing head or installed as a separate fitting, open it while the dosing pump is operating until fluid comes out. Then close it again. In the case of outgassing media, allow the fluid to flow off continuously (about 1 drop per 1 - 3 strokes). The escaping fluid flows through a hose back into the tank.
7. When correct operation has been established, set the desired delivery rate using the adjusting knob (see section 8.1) or the remote control adjustment. For an initial approximation, refer to the delivery characteristic curves (Section 5).

NOTE!

Depending on the installation and the chemicals used, these values may differ and must be checked under operating conditions.

8. The manufacturer of the dosing equipment is not responsible for damage due to excessive or insufficient flow rates at the dosing pump or incorrect or faulty installation of peripheral fittings.



9.1 Start-up of MEMDOS MR with ATE servomotor

Switch on the main drive motor of the dosing pump. An electrical interlocking system then allows ATE drive adjustment. To check the direction of rotation, send short control pulses to the ATE servomotor. If the direction of rotation is wrong, the supply lines (terminals 2 and 3 for direct controls) are reversed. To check the limit stop of the integrated limit switches, the ATE servomotor must be moved to the end position. The factory-set angle of rotation is 270°. If required, the maximum delivery rate can be changed by limiting the angle of rotation. For this purpose, the upper trigger cam is moved by the required value.

10. Shutdown

Before starting any maintenance work or before long downtimes, drain the chemicals from the dosing pump and rinse it thoroughly with a neutral medium.



CAUTION!

Excess chemicals must be disposed of properly. Observe the applicable accident prevention regulations and wear personal protective equipment.



Protective clothing



Protective gloves



Protective goggles



CAUTION!

The dosing pump must be disconnected from the voltage supply and secured to prevent it being restarted.



CAUTION!

Before disconnecting the discharge line from the pump discharge valve, release the pressure so that chemicals do not spray out.

The discharge and suction valves should be unscrewed in order to drain the dosing head.

10.1 Disposal of old equipment

If the equipment is being disposed of, it should be washed thoroughly. Residual chemicals should be disposed of properly. The equipment was manufactured in accordance with the ROHS guideline and the waste electrical equipment legislation. The manufacturer will take care of disposal if the equipment is returned free of charge. It should not be disposed of as domestic waste!

11. Maintenance

These dosing pumps are produced to the highest quality standards, and have a long service life. Nevertheless, some of their parts are subject to wear due to operation (e.g. diaphragms, valve seats, valve balls). Regular visual inspections are therefore necessary in order to ensure a long operating life. Regular maintenance will protect the dosing pump from operation interruptions. The manufacturer recommends maintenance once per year, provided the local regulations do not specify more frequent maintenance.

11.1 Lubrication

The MEMDOS MR diaphragm dosing pump requires little maintenance. The dosing pump gear is lubricated with gear oil of viscosity class ISO-VG460 according to DIN 51519 (corresponds to SAE 140 according to DIN 51512). The initial filling supplied must be replaced after about 500 operating hours. Subsequent oil changes should be carried out every 5,000 operating hours. The filling capacity is about 0.75 litre for simplex gears and about 0.9 litre for duplex gears. The actual quantity of gear oil required can be determined by reading the oil level glass. The oil should be filled to approx. the middle of the oil level glass.

11.2 Maintenance of the bearings

The upper bearing of the pinion shaft is a sealed and permanently lubricated ball bearing. The other rolling bearings in the gearing, and the plain bearings of the diaphragm rod, are lubricated by the gear oil. The oil also performs a heat dissipation function.

All bearings must be examined for wear after 5000 hours of operation. The service life of the rolling bearings depends on the applied loads. If the dosing pump is operated at maximum load, bearings must be replaced after 5,000 hours of operation.

11.3 Maintenance of the ATE servomotor (optional)

The ATE servomotor comes with lifetime lubrication ex factory. Nevertheless, regular inspections are recommended if the drive is operated in tough operating conditions, for example in high ambient temperatures or continuous operation. To re-lubricate the ATE gear, use molybdenum disulphite, for example "Molykote BR2plus" or "OKS400".

11.4 Diaphragm replacement

CAUTION!

Chemical may spray out. This may lead to chemical or other burns. The dosing pump must always be depressurised and rinsed with water or a suitable medium before starting any work on the dosing pump.

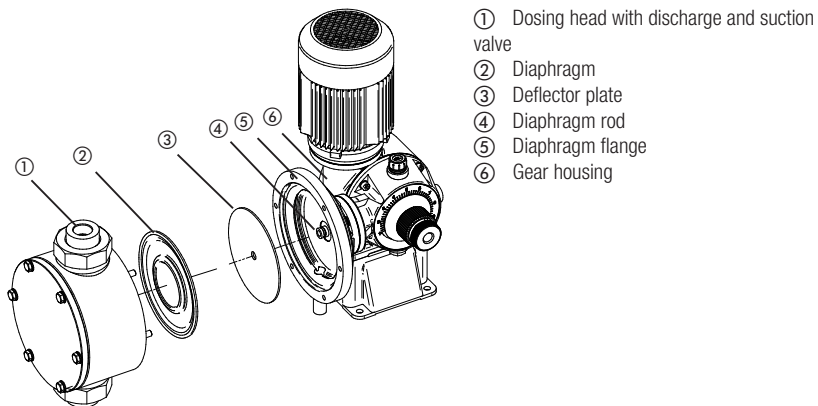

Fig. 11.1: Dosing head MEMDOS MR

The diaphragm can be replaced as follows:

1. The delivery rate of the dosing pump is set to zero while the motor is running. This moves the diaphragm to the front end position.
2. Switch off the pump.
3. The dosing head is removed using an appropriate tool. (see Fig. 1)
4. Grasp the edge of the diaphragm and turn it to the left.

IMPORTANT!

Before fitting a new diaphragm, the area around the diaphragm flange and support plate must be cleaned to remove any chemicals, otherwise they may corrode the back of the diaphragm. (see Fig. 2)

5. The new diaphragm is turned clockwise until it is screwed securely into the diaphragm rod (grease the thread).
6. The dosing pump stroke is now set to maximum while the motor is running. Switch off the motor. The diaphragm is now seated in the groove of the diaphragm flange.
7. Fit the dosing head at the front. Tighten the screws crosswise, e.g. top left – bottom right – top right – bottom left. (see Fig. 4). For the required tightening torque, see table 11.1.

IMPORTANT!

The diaphragm will not be sufficiently sealed if the tightening torque is too low. The dosing head may be damaged if the tightening torque is too high.

9. After connecting the dosing lines, the dosing pump is started as described in "Start-up" (Section 9).
10. If the diaphragm becomes worn with unusual frequency, try to determine the cause. For the possible causes, please refer to "Troubleshooting" (Section 13).

Fig. 11.2: Diaphragm replacement

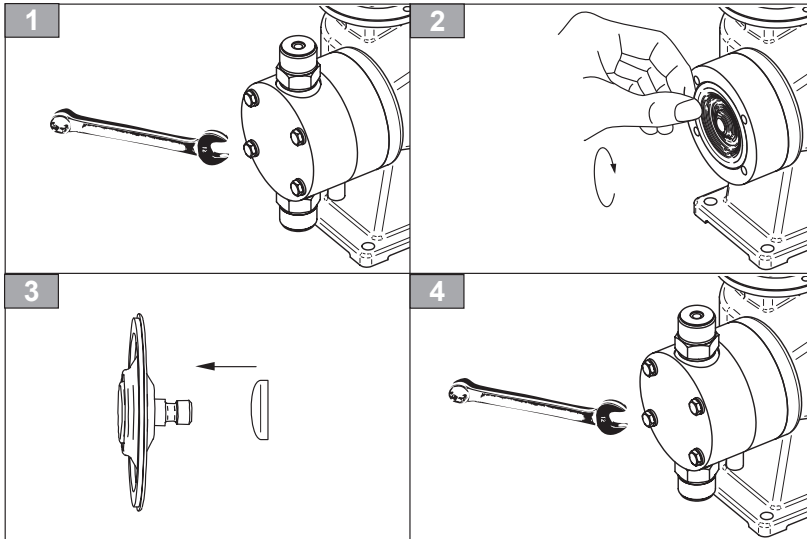

Diaphragm Ø [mm]	Torque (+/- 10%) [Nm]
90	6
120	6
150	10
185	12

Table 11.1: Required tightening torque for dosing head screws

11.5 Manual adjustment of the ATE servomotor, Type AR30W

The ATE servomotor, Type AR30W, can be moved manually using a hand crank in the event of an electrical defect. The hand crank is available as an accessory under Part No. 32.587.

Manual adjustment is carried out as described in the following:

1. Disconnect the ATE servomotor from the power supply.
2. Remove the cover from the drive unit.
3. Switch on the main drive motor.
4. Insert hand crank in corresponding opening, as shown below, and turn in desired direction.

ATTENTION!

Do not turn beyond the end positions.

5. Reattach the cover after manual adjustment.

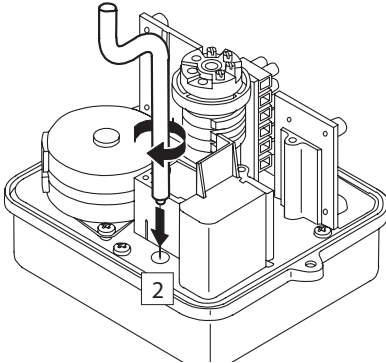

Fig. 11.3: Inserting the hand crank and turning

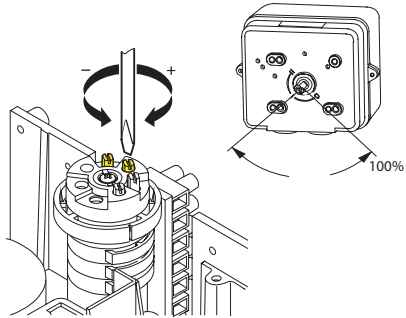

Fig. 11.4: Setting the angle of rotation

11.6 Valves

The dosing pump valves must be cleaned regularly.

NOTE!

When screwing the valves into the dosing head, observe the tightening torque of $2 \text{ Nm} \pm 20 \%$.

CAUTION!

Chemical may spray out. This may lead to chemical or other burns. The dosing pump must always be depressurised and rinsed with water or a suitable medium before starting any work on the dosing pump.

NOTE!

Dirty valves will affect the dosing accuracy.



Valves DN 10		Valve DN 25
Double-ball valves	Spring-loaded valves	Spring-loaded valve
Discharge valve		Suction and discharge valve
Suction valve		
<ul style="list-style-type: none"> ① * Flat gasket ② * Flat gasket ③ Valve body ④ Ball guide ⑤ * Valve ball ⑥ * Valve seat ⑦ * Flat gasket ⑧ * Flat gasket ⑨ * Compression spring 		<ul style="list-style-type: none"> ① O-ring ② Spring guide ③ Compression spring ④ Valve disk ⑤ O-ring ⑥ Valve seat ⑦ O-ring

* included in the spare parts kits.

12. Explosion-proof dosing pumps (ATEX)

12.1 General

The explosion-proof version of the MEMDOS MR dosing pump is an electric motor-driven, explosion-proof diaphragm dosing pump of equipment category 2, group II.

In combination with an explosion-proof motor (Ex II 2 G E Ex e II T3 or Ex II 2 G E Ex d/de IIB/IIC T4) it is used for dosing fluids Zone 1 hazardous areas. The dosing pump carries the Ex mark "Ex II 2 G c k T4 03 ATEX D086".

ATTENTION!

The dosing pump is not intended for dosing gaseous media or solids.



12.2 Special conditions

The minimum requirements for the zone classification must be ensured if using the dosing pump in areas with a potentially explosive atmosphere. The dosing pump itself and the motor must meet the minimum requirements.

12.3 Dosing of flammable media

If dosing flammable fluids, all metal parts in the suction and discharge pipes must be grounded to prevent electrostatic discharge.

Stainless steel is recommended for the dosing head.

Dosing pumps with diaphragms more than 90 mm in diameter are equipped with special conductive diaphragms to prevent static charging. When obtaining replacement parts, order original diaphragms only.

13. Troubleshooting

Problem	Possible cause	Remedy
Dosing pump not delivering or output too low.	Valves leaking or blocked.	Clean the valves and vent the dosing pump. See also "Start-up" Tighten the screw connections.
	Valves incorrectly installed.	Reassemble the valves. Ensure that the valve balls are located above the valve seats.
	Suction valve or suction line leaking or blocked.	Clean or seal the suction line.
	Suction lift too high.	- Set the dosing pump at the inlet. - Install the pulsation damper on the suction side. - Install a priming aid.
	Viscosity too high.	- Install spring-loaded valves. - Increase the pipe diameter. - Use a special dosing head. >> Contact manufacturer
No stroke movement	Dosing pump set to zero stroke.	Set the stroke length adjusting knob correctly.
	Diaphragm return spring broken.	Replace the spring.
	Power supply interrupted.	Switch on power supply.
Dosing pump delivery rate too high	Suction side pressure too high (pump siphoning)	Install a pressure control valve on the discharge line.
Diaphragm cracks frequently	Diaphragm not screwed up to the end stop on the diaphragm rod	Screw a new diaphragm up to the end stop. On E/DX 50 ... 76, the support plate must be clamped firmly between diaphragm and diaphragm rod.
	System backpressure too high (measured at discharge connection of dosing pump)	Inspect the system. Clean blocked injection nozzle. Install pulsation dampers to reduce pressure peaks if pipes are too long. Check that safety valves are working (see installation example).
	Media sediment in dosing head.	Clean the dosing head.
Dosing pump very noisy.	Roller bearing defective.	Replace the roller bearing.
	No oil in the gearing, or too little	Top up the oil as described in "Maintenance".
Motor hums and does not start.	Wrongly connected.	Check electrical wiring.
	Capacitor defective, wrong size or connected incorrectly.	Connect the capacitor correctly or replace.
	Pressure too high.	Check the process.

If the problem cannot be solved with the above remedies, please return the dosing pump to the factory or contact our After-Sales Service for further assistance. Repairs will be carried out immediately.

14. Spare parts

Use the manufacturer's original spare parts. Wear parts are available for the MEMDOS MR in spare parts sets.

14.1 Spare parts sets

The spare parts sets consist of:

- Flat gaskets
- Valve balls
- Valve seats
- Diaphragms
- Shaft seal

MEMDOS	Material		Part No.
	Dosing head	Seal	
MR 50 ... 150	PP	CSM	25411
	PP	FPM	25423
	1.4571	asbestos-free (AF)	25435
MR 140 ... 210	PP	CSM	25412
	PP	FPM	25424
	1.4571	AF	25436
MR 290	PP	CSM	25413
	PP	FPM	25425
	1.4571	AF	25437
MR 400 ... 980	PP	CSM	34504
	PP	FPM	34505
	1.4571	CSM	34506
	1.4571	FPM	34507

15. External vent (optional)

Functional description of vent motors

The fan cowl and fan blade of the drive motor are removed and replaced by the extended fan cowl with integrated fan. The fan has a direct mains connection, and therefore delivers the maximum quantity of cool air to protect the motor against overheating at all speeds. Separate fans can be operated over a wide voltage range, according to the technical data. They can be connected to three-phase or alternating current power supply, if connected according to the instructions. For single-phase operation, an operating capacitor is included in the terminal box (see electrical wiring diagram). The fan motors work according to the direction of rotation. The air flow must be directed towards the motor.

Special versions available

- Extended fan cowl (for operation with tachogenerator or motor brake)
- Alternative mounting bracket
- Different fan cowl diameter

Technical data							
Motor size	63	71	80	90	100	112	
Air flow rate m ³ /h	47	60	88	169	208	295	
Power consumption W	27	30	28.5	86	86	84.5	
Speed at 50 Hz (rpm)	2910	2870	2790	2880	2830	2770	
Sound pressure level dB(A)	47	51	55	58	59	61	
Protection class	IP 66						
Dimensions (mm)	Height	185	190	195	205	210	215
	Diameter	126	143	160	176	196	220
Nominal motor current (A)							
3~, 200 ... 290 V, Delta	0.092	0.095	0.090	0.28	0.27	0.27	
3~, 346 ... 500 V, Y	0.06	0.06	0.05	0.06	0.06	0.06	
1~, 230 V	0.075	0.081	0.090	0.19	0.21	0.23	
Part No.							
Motor supplier ATB	47000200	47000201	47000202	47000203	47000204	47000205	
Motor supplier VEM	-	47000101	47000100	-	-	-	
Motor supplier Siemens	-	-	47000303	-	-	-	

Electrical wiring diagram

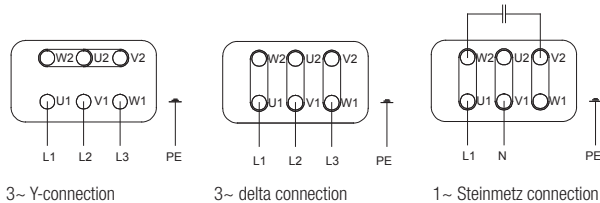

Index

A		P	
Ambient temperature	11	Pressure control and safety valves	22
Area with a potentially explosive atmosphere	18	Principle of operation	8
B		Protective clothing.....	5
Bearings.....	27	R	
C		Revision	24
Chemical leakage	18	S	
D		Scope of delivery	6
Delivery characteristic curves	16	Separate fan.....	34
Diaphragm replacement	27	Servomotor.....	14
Diaphragm wear	28	Shutdown	26
Dimensioned drawings.....	9	Spare parts.....	33
Disposal	26	Start-up.....	25
Dosing head.....	7	Stroke frequency.....	11
Dosing of chemicals.....	5	Stroke length	11
E		Stroke length adjustment.....	24
Electrical connection	19	Stroke volume.....	11
Electric motor data.....	12	Structure of the dosing pump.....	7
Explosion-proof.....	31	T	
Explosion-proof motors.....	13	Technical data	11
F		Tightening torque	28
Fault	32	Training.....	3
Function	8	Troubleshooting	32
I		V	
Injection nozzle	22	Valves	29
Installation	18	W	
Installation example	23	Warranty claim.....	37
Installation location	19	Wiring diagram for the drive motor	20
L		Y	
Lubrication	27	Y-connection.....	20
M			
Maintenance.....	27		
O			
Oil inlet.....	7		
Oil outlet.....	7		
Operation	24		

Declaration of no objection

When sending in for repair, please copy this form, fill in and send along with each device!

Declaration of No Objection - Form

(please fill in one form for each device and attach it to the outside of the device)

We are returning the following device for repair:

Device and device type:

Part No.:

Order No.:

Date of delivery:

Reason for repair:

Medium conveyed

Description:

Properties:

Irritant: Yes/No*) Corrosive: Yes/No*)

*) Please delete as appropriate!

We hereby certify that the product has been cleaned thoroughly on the inside and outside before shipment, that it is free from hazardous chemical, biological, or radioactive substances and that the oil has been drained. *)

If the manufacturer finds it necessary to carry out further cleaning work, we will accept the related costs.

We confirm that the above statements are correct and complete and that the device is being shipped according to legal requirements.

Company:

Address:

.....

.....

Telephone:

Fax:

E-mail:

Customer No.:

Contact person:

Date, signature, stamp:

Warranty claim

Please copy and enclose with the device!

If the device fails during the warranty period, please clean it and return, accompanied by the completed warranty claim form.

Sender

Company:..... Telephone:..... Date:.....

Address:.....

Contact person:

Manufacturer order No.:..... Date of delivery:

Device type:..... Serial number:.....

Nominal delivery rate:/Nominal pressure:.....

Description of fault:

.....

Type of fault:

1. Mechanical fault

Premature wear

Wearing parts

Breakage/other damage

Corrosion

Damage in transit

2. Electrical fault

Connections, connectors or cables loose

Operating controls (e.g. switches / push-buttons)

Electronics

3. Leaks

Connections

Dosing head

4. No or inadequate operation

Diaphragm defective

Other

Operating conditions of the device

Location/description of installation:

Accessories used if any:

.....

.....

Commissioning (date):.....

Running time (approx. operating hours):

Please indicate the specific features of the installation and enclose a simple sketch showing materials, diameters, lengths and heights.

EU-Konformitätserklärung

Der Unterzeichnete Lutz-Jesco GmbH, Am Bostelberge 19, 30900 Wedemark, bestätigt, dass die nachfolgend bezeichneten Geräte in der von uns in Verkehr gebrachten Ausführung die Anforderungen der harmonisierten EU-Richtlinien, EU-Sicherheitsstandards und produktspezifischen Standards erfüllen. Bei einer nicht mit uns abgestimmten Änderung der Geräte verliert diese Erklärung ihre Gültigkeit.

(EN) EU Certificate of Conformity

The undersigned Lutz-Jesco GmbH, Am Bostelberge 19, 30900 Wedemark, hereby certifies that, when leaving our factory, the units indicated below are in accordance with the harmonised EU guidelines, EU standards of safety and product specific standards. This certificate becomes void if the units are modified without our approval.

(FR) Certificat de conformité aux directives européennes

Le constructeur, soussigné: Lutz-Jesco GmbH, Am Bostelberge 19, 30900 Wedemark, déclare qu'à la sortie de ses usines le matériel neuf désigné ci-dessous était conforme aux prescriptions des directives européennes énoncées ci-après et conforme aux règles de sécurité et autres règles qui lui sont applicables dans le cadre de l'Union européenne. Toute modification portée sur ce produit sans l'accord express de Jesco supprime la validité de ce certificat.

(ES) Declaración de conformidad de la UE

El que suscribe Lutz-Jesco GmbH, Am Bostelberge 19, 30900 Wedemark, declara que la presente mercancía, objeto de la presente declaración, cumple con todas las normas de la UE, en lo que a normas técnicas, de homologación y de seguridad se refiere, en caso de realizar cualquier modificación en la presente mercancía sin nuestra previa autorización, esta declaración pierde su validez.

(NL) EU-overeenstemmingsverklaring

Ondergetekende Lutz-Jesco GmbH, Am Bostelberge 19, 30900 Wedemark, bevestigt, dat het volgende genoemde apparaat in de door ons in de handel gebrachte uitvoering voldoet aan de eis van, en in overeenstemming is met de EU-richtlijnen, de EU-veiligheidsstandaard en de voor het product specifieke standaard. Bij een niet met ons afgestemde verandering aan het apparaat verliest deze verklaring haar geldigheid.

(HU) EG (EK)– Egyezőségi nyilatkozat

A Lutz-Jesco GmbH, Am Bostelberge 19, 30900 Wedemark ezúton kijelenti, hogy a szóban forgó termék annak tervezése és szerkezeti módja, valamint forgalomba hozott kivitele alapján a vonatkozó alapvető biztonságtechnikai és egészségügyi követelményeknek és az alábbi felsorolt EG –írányelveknek minden szempontból megfelel. A terméknek engedélyünk nélkül végrehajtott módosítások következtében jelen nyilatkozat érvényét veszíti.

(PT) Certificado de conformidade da UE

Os abaixo mencionados Lutz-Jesco GmbH, Am Bostelberge 19, 30900 Wedemark, por este meio certificam que ao sair da fábrica o aparelho abaixo mencionado está de acordo com as directrizes harmonizadas da UE, padrões de segurança e de produtos específicos. Este certificado ficará nulo se a unidade for modificada sem a nossa aprovação.

Bezeichnung des Gerätes:	Membran-Dosierpumpe
Description of the unit:	Diaphragm Metering Pump
Désignation du matériel:	Pompes doseuses à membrane mécanique
Descripción de la mercancía:	Bombas dosificadoras de membrana
Omschrijving van het apparaat:	Membraandoseerpomp
A termék megnevezése:	Membrán adagolószivattyúk
Designação do aparelho:	

Typ / Type / Tipo / Típusjelölés:

MINIDOS A
MIDIDOS E
MEMDOS E
MEMDOS M
MEMDOS ML
MEMDOS MR
MEMDOS GMR
MEMDOS TM

EU-Richtlinie / EU directives/
 Directives européennes / Normativa UE /
 EU-richtlijnen / Vonatkozó EG-írányelvek /
 Directrizes da UE
2006/95/EG
2006/42/EG

Harmonisierte Normen / harmonized
 standards / Normes harmonisées /
 Estándares acordemente / Toegepaste normeringen /
 Hatályos normák / Normas harmonizadas
EN ISO 12100-1 : 2003
EN ISO 12100-2 : 2003
EN 809 : 1998

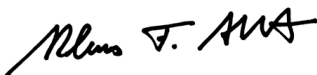

i.V. Dipl. Ing. Klaus Albert
 Lutz-Jesco, Wedemark, 21.12.2009

Technische Leitung / Technical Department Manager / Direction technique /
 Dirección Técnica / Hoofd technische dienst / Műszaki irodavezető / Director Técnico

EU-Konformitätserklärung

Der Unterzeichnete Lutz-Jesco GmbH, Am Bostelberge 19, 30900 Wedemark, bestätigt, dass die nachfolgend bezeichneten Geräte in der von uns in Verkehr gebrachten Ausführung die Anforderungen der harmonisierten EU-Richtlinien, EU-Sicherheitsstandards und produktspezifischen Standards erfüllen. Bei einer nicht mit uns abgestimmten Änderung der Geräte verliert diese Erklärung ihre Gültigkeit.

(EN) EU Certificate of Conformity

The undersigned Lutz-Jesco GmbH, Am Bostelberge 19, 30900 Wedemark, hereby certifies that, when leaving our factory, the units indicated below are in accordance with the harmonised EU guidelines, EU standards of safety and product specific standards. This certificate becomes void if the units are modified without our approval.

(FR) Certificat de conformité aux directives européennes

Le constructeur, soussigné: Lutz-Jesco GmbH, Am Bostelberge 19, 30900 Wedemark, déclare qu'à la sortie de ses usines le matériel neuf désigné ci-dessous était conforme aux prescriptions des directives européennes énoncées ci-après et conforme aux règles de sécurité et autres règles qui lui sont applicables dans le cadre de l'Union européenne. Toute modification portée sur ce produit sans l'accord express de Jesco supprime la validité de ce certificat.

(ES) Declaración de conformidad de la UE

El que suscribe Lutz-Jesco GmbH, Am Bostelberge 19, 30900 Wedemark, declara que la presente mercancía, objeto de la presente declaración, cumple con todas las normas de la UE, en lo que a normas técnicas, de homologación y de seguridad se refiere, En caso de realizar cualquier modificación en la presente mercancía sin nuestra previa autorización, esta declaración pierde su validez.

(NL) EU-overeenstemmingsverklaring

Ondergetekende Lutz-Jesco GmbH, Am Bostelberge 19, 30900 Wedemark, bevestigt, dat het volgende genoemde apparaat in de door ons in de handel gebrachte uitvoering voldoet aan de eis van, en in overeenstemming is met de EU-richtlijnen, de EU-veiligheidsstandaard en de voor het product specifieke standaard. Bij een niet met ons afgestemde verandering aan het apparaat verliest deze verklaring haar geldigheid.

(HU) EG (EK)– Egyezőségi nyilatkozat

A Lutz-Jesco GmbH, Am Bostelberge 19, 30900 Wedemark ezúton kijelenti, hogy a szóban forgó termék annak tervezése és szerkezeti módja, valamint forgalomba hozott kivitele alapján a vonatkozó alapvető biztonság technikai és egészségügyi követelményeknek és az alábbi felsorolt EG –irányelveknek minden szempontból megfelel. A terméken engedélyünk nélkül végrehajtott módosítások következtében jelen nyilatkozat érvényét veszíti.

(PT) Certificado de conformidade da UE

Os abaixo mencionados Lutz-Jesco GmbH, Am Bostelberge 19, 30900 Wedemark, por este meio certificam que ao sair da fábrica o aparelho abaixo mencionado está de acordo com as directrizes harmonizadas da UE, padrões de segurança e de produtos específicos. Este certificado ficará nulo se a unidade for modificada sem a nossa aprovação.

Bezeichnung des Gerätes:	Explosionssgeschützte Membran-Dosierpumpe
Description of the unit:	Explosion proofed Diaphragm Metering Pump
Désignation du matériel:	Pompes doseuses à membrane mécanique Zone Exx
Descripción de la mercancía:	Bombas dosificadoras de membrana antideflagrante
omschrijving van het apparaat:	Explosieveilige Membraandoseerpomp EX
A termék megnevezése:	Membrán - adagolószivattyúk robbanásbiztos kivitelben EX
Designação do aparelho:	

Typ / Type / Tipo / Típusjelölés:

MEMDOS MR-Ex
MEMDOS E-Ex

EU-Richtlinie / EU directives/
Directives européennes / Normativa UE /
EU-richtlijnen / Vonatkozó EG-irányelvek /
Directrizes da UE

2006/95/EG
2006/42/EG
94/9/EG

Harmonisierte Normen / harmonized
standards / Normes harmonisées /
Estándares acordemente / Toegepaste normeringen /
Hatályos normák / Normas harmonizadas

EN ISO 12100-1 : 2003
EN ISO 12100-2 : 2003
EN 809 : 1998
EN 13463-1 : 2001

ATEX-Registrier-Nr. : Memdos E: Ex II 2 G c k T4 03 ATEX D085, Memdos MR: Ex II 2 G c k T4 03 ATEX D086

ATEX-Registration No. : Memdos E: Ex II 2 G c k T4 03 ATEX D085, Memdos MR: Ex II 2 G c k T4 03 ATEX D086

i.V. Dipl. Ing. Klaus Albert
Lutz-Jesco, Wedemark, 21.12.2009

Technische Leitung / Technical Department Manager / Direction technique /
Dirección Técnica / Hoofd technische dienst / Műszaki irodavezető / Director Técnico



Lutz-Jesco GmbH

Am Bostelberge 19
30900 Wedemark
Germany

Telephone: +49 5130 5802-0
Fax: +49 5130 580268
info@lutz-jesco.com
www.lutz-jesco.com/de

24h-Hotline: +49 5130 580 280

Austria

Lutz-Jesco GmbH

Aredstraße 7/2
2544 Leobersdorf
Austria

Telephone: +43 2256 62180
Fax: +43 2256 6218062
info@lutz-jesco.at
www.lutz-jesco.at

Great Britain

Lutz-Jesco (GB) Ltd.

Gateway Estate
West Midlands Freeport
Birmingham B26 3QD
Great Britain

Telephone: +44 121 782 2662
Fax: +44 121 782 2680
info@lutz-jesco.co.uk
www.lutz-jesco.co.uk

Netherlands

Lutz-Jesco Nederland B.V.

Nijverheidstraat 14 C
2984 AH Ridderkerk
Netherlands

Telephone: +31 180 499460
Fax: +31 180 497516
info@lutz-jesco.nl
www.lutz-jesco.nl

Hungary

Lutz-Jesco Üzetág

Vasvári P. u. 9.
9024 Győr
Hungary

Telephone: +36 96 523046
Fax: +36 96 523047
info@lutz-jesco.hu
www.lutz-jesco.hu

USA

Lutz-JESCO America Corp.

55 Bermar Park
Rochester, NY 14624
USA

Telephone: +1 585 426-0990
Fax: +1 585 426-4025
mail@jescoamerica.com
www.jescoamerica.com

East Asia

Lutz-Jesco
East Asia Sdn Bhd
6 Jalan Saudagar U1/16
Hicom Glenmarie Industrial Park
40150 Shah Alam /Selangor
Malaysia

Telephone: +603 5569 2322
Fax: +603 5569 1322
info@lutz-jescoasia.com
www.lutz-jescoasia.com

Middle East

Lutz-Jesco Middle East FZE

P.O. Box 9614
SAIF-Free Zone Center
Sharjah
UAE

Telephone: +971 6 5572205
Fax: +971 6 5572230
info@jescome.com
www.jescome.com



BA-10502-02-V02
Subject to technical changes
and inaccuracies
© Lutz-Jesco GmbH 06.2010
Printed in Germany