

# Motor-driven Diaphragm Dosing Pump **MEMDOS LB** Operating Instructions

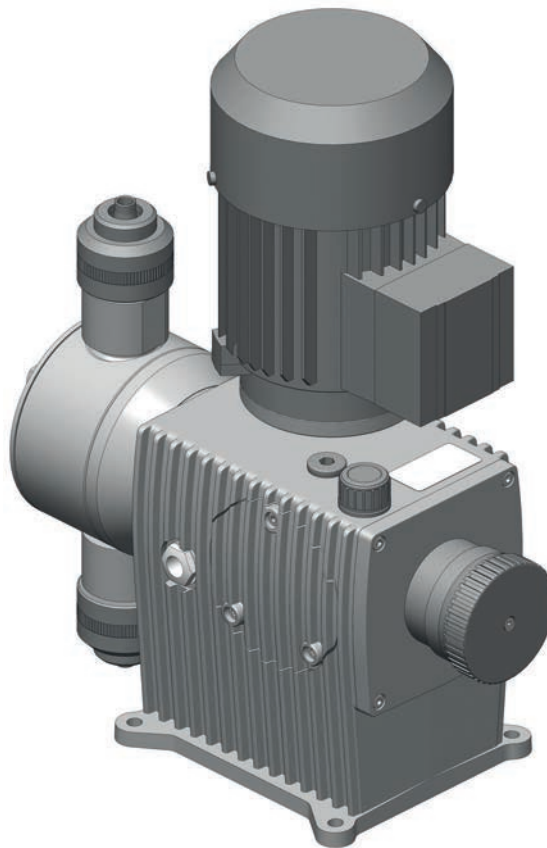

Read the Operating instructions!

The user is responsible for installation and operation related mistakes!



## Contents

<b>1</b>	<b>Notes to the Reader</b> .....	4	<b>10</b>	<b>Control</b> .....	34
	General non-discrimination .....	4		Stroke length adjustment .....	34
	Explanations of signal words .....	4	<b>11</b>	<b>Operation</b> .....	35
	Warning signs explanation .....	4		Commissioning the dosing pump .....	36
	Warnings identification .....	4		Commissioning the electric servomotor .....	37
	Instruction for action identification .....	4		Decommissioning the dosing pump .....	37
<b>2</b>	<b>Safety</b> .....	5		Shutting down in an emergency .....	37
	General warnings .....	5		Storage .....	37
	Warnings for use within explosive-risk zones .....	6		Transportation .....	37
	Hazards due to non-compliance with the safety instructions .....	6		Disposal of old units .....	37
	Safe operation .....	6	<b>12</b>	<b>Maintenance</b> .....	38
	Personal protective equipment .....	6		Maintenance intervals .....	39
	Personnel qualification .....	6		Change the oil .....	39
<b>3</b>	<b>Appropriate and intended use</b> .....	8		Tighten dosing head bolts .....	40
	Notes to product warranty .....	8		Diaphragm replacement .....	40
	Intended purpose .....	8		Clean suction and pressure valves .....	41
	Device revision .....	8	<b>13</b>	<b>Troubleshooting</b> .....	42
	Principles .....	8		Type of fault .....	42
	Prohibited dosing media .....	8	<b>14</b>	<b>Spare parts</b> .....	45
	Use in explosion risk areas .....	8		Diaphragm spare parts kits .....	45
	Foreseeable misuse .....	9		Dosing head spare parts kits including valves .....	45
<b>4</b>	<b>Product Description</b> .....	11	<b>15</b>	<b>Delivery characteristic curves</b> .....	49
	Properties .....	11	<b>16</b>	<b>EC Declaration of Conformity</b> .....	51
	Scope of delivery .....	11	<b>17</b>	<b>Declaration of harmlessness</b> .....	53
	Structure of the dosing pump .....	11	<b>18</b>	<b>Warranty application</b> .....	55
	Function description .....	12	<b>19</b>	<b>Index</b> .....	57
<b>5</b>	<b>Technical specifications</b> .....	13			
	Delivery capacity data .....	13			
	Operating conditions and limits .....	14			
	Other data .....	14			
	Motor data .....	16			
	Electric servomotors .....	19			
<b>6</b>	<b>Dimensions</b> .....	20			
	MEMDOS LB 4 – 80, 150 .....	20			
	MEMDOS LB 110, 160 – 1010 .....	21			
	MEMDOS LB 4 – 80, 150 with electric servomotor .....	22			
	MEMDOS LB 110, 160 – 1010 with electric servomotor .....	22			
<b>7</b>	<b>Dosing pump installation</b> .....	23			
	Set up information .....	23			
	Installation on a wall console .....	23			
<b>8</b>	<b>Hydraulic installations</b> .....	24			
	Design of the system .....	24			
	System piping .....	25			
	Suction and pressure valves .....	25			
	Connecting a leakage drain .....	25			
	Hydraulic accessories .....	26			
<b>9</b>	<b>Electrical installation</b> .....	32			
	Drive motor connection .....	32			

# 1 Notes to the Reader

These Operating instructions contain information and behaviour rules for safe and designated operation of the Motor-driven Diaphragm Dosing Pump MEMDOS LB.

Follow these principles:

- Read the entire Operating instructions prior to commissioning the unit.
- Ensure that everyone who works with or on the dosing pump has read the operating instructions and follows them.
- Keep the operating instructions for the entire service life of the dosing pump.
- Pass on the operating instructions to any subsequent owner of the dosing pump.

## 1.1 General non-discrimination

In these operating instructions, only the male gender is used where grammar allows gender allocation. The purpose of this is to make the text easy to read. Men and women are always referred to equally. We would like to ask female readers for understanding of this text simplification.

## 1.2 Explanations of signal words

Different signal words in combination with warning signs are used in these Operating instructions. Signal words illustrate the gravity of possible injuries if the risk is ignored:

Signal word	Meaning
DANGER	Refers to imminent danger. Ignoring this sign may lead to death or the most serious injuries.
WARNING	Refers to a potentially hazardous situation. Ignoring this sign might lead to death or the most serious injuries.
CAUTION	Refers to a potentially hazardous situation. Ignoring this sign may lead to light injuries or damage to property.
NOTICE	Refers to a danger which, if ignored, may compromise the unit or its function.

Table 1-1: Explanations of signal words

## 1.3 Warning signs explanation

Warning signs represent the type and source of a danger:

Warning sign	Type of danger
	Danger of personal injury and material damage.
	Danger of electric shock.
	Danger of caustic burns or other burns.
	Danger of explosion.
	Danger of automatic start up.
	Danger of damage to machine or compromised function.

Table 1-2: Warning signs explanation

## 1.4 Warnings identification

Warnings are intended to help you recognise risks and avoid negative consequences.

This is how warnings are identified:

Warning sign	SIGNAL WORD
	<p><b>Description of danger.</b></p> <p>Consequences if ignored.</p> <p>⇒ The arrow signals a precautionary measure to be taken to eliminate the danger.</p>

## 1.5 Instruction for action identification

This is how pre-conditions for action are identified:

- ✓ Pre-condition for action which must be met before taking action.

This is how instructions for action are identified:

- ➔ Separate step with no follow-up action.
- 1. First step in a series of steps.
- 2. Second step in a series of steps.
  - ▶ Result of the above action.
- ✓ **Action completed, aim achieved.**

## 2 Safety

### 2.1 General warnings

The following warnings are intended to help you to eliminate the dangers that can arise while handling the dosing pump. Risk prevention measures always apply regardless of any specific action.

Safety instructions warning against risks arising from specific activities or situations can be found in the respective sub-chapters.

	<b>DANGER</b>
<p><b>Danger to life due to electric shock!</b></p> <p>Wrongly connected or located cables or damaged ones can injure you.</p> <ul style="list-style-type: none"> <li>⇒ Only connect the device to an earthed power supply.</li> <li>⇒ Replace damaged cables without delay.</li> <li>⇒ Do not use extension cables.</li> <li>⇒ Do not bury cables.</li> <li>⇒ Secure cables to avoid being damaged by other equipment.</li> </ul>	

	<b>WARNING</b>
<p><b>Caustic burns or other burns through dosing media!</b></p> <p>After connecting the mains supply, residual dosing media in the dosing head can spray out.</p> <ul style="list-style-type: none"> <li>⇒ Before connecting the mains supply, connect the dosing lines.</li> <li>⇒ Check that all the screw connections have been tightened correctly and are leak-proof.</li> </ul>	

	<b>WARNING</b>
<p><b>Caustic burns or other burns through dosing media!</b></p> <p>While working on the dosing head, valves and connections, you may come into contact with dosing media.</p> <ul style="list-style-type: none"> <li>⇒ Use sufficient personal protective equipment.</li> <li>⇒ Rinse the dosing pump with a liquid (e.g. water) which does not pose any risk. Ensure that the liquid is compatible with the dosing medium.</li> <li>⇒ Release pressure in hydraulic parts.</li> <li>⇒ Never look into open ends of plugged pipelines and valves.</li> </ul>	

	<b>WARNING</b>
<p><b>Caustic burns or other burns through dosing media!</b></p> <p>The materials of the dosing pump and hydraulic parts of the system must be suitable for the dosing medium that is used. Should this not be the case, the dosing media may leak.</p> <ul style="list-style-type: none"> <li>⇒ Make sure that the materials you are using are suitable for the dosing medium.</li> <li>⇒ Make sure that the lubricants, adhesives, sealants, etc. that you use are suitable for the dosing medium.</li> </ul>	

	<b>CAUTION</b>
<p><b>Increased risk of accidents due to insufficient qualification of personnel!</b></p> <p>Dosing pumps and their accessories may only be installed, operated and maintained by personnel with sufficient qualifications. Insufficient qualification will raise the risk of accidents.</p> <ul style="list-style-type: none"> <li>⇒ Ensure that all action is taken only by personnel with sufficient and corresponding qualifications.</li> <li>⇒ Prevent access to the system for unauthorised persons.</li> </ul>	

	<b>CAUTION</b>
<p><b>Danger of personal injury and material damage!</b></p> <p>Changing dosing media can lead to unpredictable reactions.</p> <ul style="list-style-type: none"> <li>⇒ Thoroughly clean the dosing pump and appropriate sections of the plant to avoid chemical reactions.</li> </ul>	

## 2.2 Warnings for use within explosive-risk zones

ATEX certified versions of MEMDOS LB dosing pump can be used in explosive risk areas. The following warnings only apply for use in such areas:

	<b>DANGER</b>
<p><b>Danger to life through explosions!</b></p> <p>Explosions may result which could result in fatal injuries.</p> <p>⇒ Use only ATEX certified versions of the MEMDOS LB dosing pump in explosive risk areas (check the information on the ratings plate for this).</p>	

	<b>DANGER</b>
<p><b>Danger to life through explosions!</b></p> <p>Static electricity in explosive risk areas can build up when dosing flammable liquids. Explosions may result which could result in fatal injuries.</p> <p>⇒ Earth the dosing pump, drive motor and all metal parts along the suction and pressure piping route.</p> <p>⇒ Only use dosing heads made of stainless steel. In exceptional cases, carbon-filled PTFE dosing heads are also possible. In this event, contact the Lutz-Jesco GmbH.</p>	

	<b>DANGER</b>
<p><b>Danger to life through explosions!</b></p> <p>Original Lutz-Jesco GmbH diaphragms more than 90 mm in diameter are fitted with special conductive diaphragms to prevent static charging. If unsuitable diaphragms from other manufacturers are fitted, this can lead to electrostatic charging in explosive risk areas. Explosions may result which could result in fatal injuries.</p> <p>⇒ Only use original diaphragms for spare parts. This applies to MEMDOS LB 80 – 1010 dosing pumps.</p>	

## 2.3 Hazards due to non-compliance with the safety instructions

Failure to observe the safety instructions can pose a risk not only to the personnel, but consequentially to the environment and the unit.

The specific consequences can be:

- Failure of vital functions of the dosing pump and the system,
- failure of required maintenance and repair methods,
- danger for individuals through dangerous dosing media,
- danger to the environment through substances leaking from the system.

## 2.4 Safe operation

Besides the safety instructions specified in these Operating instructions, further safety rules apply and must be followed:

- Accident prevention regulations,
- safety and operating provisions,
- safety provisions for handling dangerous substances (mostly the safety data sheets to dosing media),
- environmental protection provisions,
- applicable standards and legislation.

## 2.5 Personal protective equipment

Based on the degree of risk posed by the dosing medium and the type of work you are carrying out, you must use corresponding protective equipment. Read the Accident Prevention Regulations and the Safety Data Sheets to the dosing media find out what protective equipment you need.

As a minimum, the following protective equipment is recommended:



Protective clothing



Protective gloves



Goggles

Corresponding protective equipment must be used during these tasks:

- Commissioning,
- working on the dosing pump while running,
- decommissioning,
- maintenance work,
- disposal.

## 2.6 Personnel qualification

Any personnel who work on the dosing pump must have appropriate special knowledge and skills.

Anybody who works with the dosing pump must meet the conditions below:

- Attendance at all the training courses offered by the owner,
- Personal suitability for the respective job,
- Sufficient qualification for the respective job,
- Training in handling of the dosing pump,
- Knowledge of safety equipment and the way this equipment functions,
- Knowledge of these Operating instructions, particularly of safety instructions and sections relevant for the job,
- Knowledge of fundamental regulations regarding health and safety and accident prevention.

All persons must generally have the following minimum qualification:

- Training as specialists to carry out work on the dosing pump unsupervised,
- Sufficient training that they can work on the dosing pump under the supervision and guidance of a trained specialist.

These Operating instructions differentiate these user groups:

### 2.6.1 Specialist staff

Specialist staff are able, thanks to their professional training, knowledge and experience as well as knowledge of the respective provisions, to do the job allocated to them and recognise and/or eliminate any possible dangers by themselves.

### 2.6.2 Trained electricians

Due to their professional training, knowledge and experience as well as knowledge of specific standards and provisions, trained electricians are able to do the electrical work assigned to them and to recognise and avoid any any potential dangers by themselves.

They are specially trained for their specific working environment and are familiar with relevant standards and provisions.

They must comply with the legally binding regulations on accident prevention.

### 2.6.3 Trained electricians with additional qualification for explosion protection

Trained electricians with additional qualification for explosion protection fulfil the criteria to act as a competent person to meet all the special requirements needed when working in explosive risk areas.

They are specially trained for their work environment in explosive risk areas and know all the relevant standards and regulations.

Above all, they have the required specialist knowledge about explosion protection like, for example, ignition protection classes, flash points, density ratios, zoning, device categories, temperature classes etc.

### 2.6.4 Trained persons

Trained persons have been trained by the operator into the tasks they are supposed to perform and into the dangers stemming from improper behaviour.

In the table below you can check what qualifications are the pre-condition for the respective tasks. Only people with appropriate qualifications are allowed to perform these tasks!

Qualification	Tasks
Specialist staff	<ul style="list-style-type: none"> <li>■ Assembly</li> <li>■ Hydraulic installations</li> <li>■ Maintenance</li> <li>■ Repairs</li> <li>■ Commissioning</li> <li>■ Decommissioning</li> <li>■ Disposal</li> <li>■ Troubleshooting</li> </ul>
Trained electricians	<ul style="list-style-type: none"> <li>■ Electrical installation</li> <li>■ Installing the electric servomotor</li> <li>■ Rectifying electrical faults</li> </ul>
Trained electricians with additional qualification for explosion protection	<ul style="list-style-type: none"> <li>■ Electrical installation in explosive risk areas</li> <li>■ Fault rectification in explosive risk areas</li> </ul>
Trained persons	<ul style="list-style-type: none"> <li>■ Storage</li> <li>■ Transportation</li> <li>■ Control</li> <li>■ Troubleshooting</li> </ul>

Table 2-1: Personnel qualification

### 3 Appropriate and intended use

#### 3.1 Notes to product warranty

Any non-designated use of the product can compromise its function or intended protection. This leads to invalidation of any warranty claims!

Please note that liability is on the side of the user in the following cases:

- The dosing pump is operated in a manner which is not consistent with these Operating instructions, particularly the safety and handling instructions and the chapter entitled "Appropriate and intended use".
- If people operate the product who are not adequately qualified to carry out their respective activities,
- No original spare parts or accessories of Lutz-Jesco GmbH are used,
- Unauthorised changes are made to the device by the user,
- The user uses different dosing media than those indicated in the order,
- The user does not use dosing media under the conditions agreed with the manufacturer such as modified concentration, density, temperature, contamination, etc.

#### 3.2 Intended purpose

The MEMDOS LB dosing pump is intended for the following purpose: the conveying and dosing of liquids.

#### 3.3 Device revision

This operating manual applies to the following devices:

Device	Month / year of manufacture
MEMDOS LB	07/2012 onwards

Table 3-1: Device revision

#### 3.4 Principles

- Before delivery, the manufacturer inspected the dosing pump and operated it under specific conditions (with a specific dosing medium with a specific density and temperature, with specific pipe dimensions, etc.) Since these conditions vary at every installation location, you must calibrate the dosing pump after delivery. For details on the approximate values and the capacity of the dosing pump, refer to the chapter entitled "Delivery characteristic curves" (see page 49).
- Information on the usage and environment (see „Technical specifications“ on page 13) applies.
- Any restrictions regarding the viscosity, temperature and density of dosing media must be followed. You must only use dosing media at temperatures above freezing point or below the boiling point of the respective medium.
- The materials of the dosing pump and hydraulic parts of the system must be suitable for the dosing medium that is used. In this connection, note that the resistance of these components can change in dependence on the temperature of the media and the operating pressure.



Information on the suitability of materials combined with different dosing media can be found in the Chemical Resistance List of Lutz-Jesco GmbH.

The information in this resistance list is based on information from the material manufacturers and on expertise obtained by Lutz-Jesco from handling the materials.

As the durability of the materials depends on many factors, this list only constitutes initial guidance on selecting material. In all cases, test the equipment with the chemicals you use under operating conditions.

- The dosing pump is not intended for outdoor use unless appropriate protective measures have been taken.
- Prevent leaks of liquids and dust into the casing and avoid direct exposure to sun light.
- You must never operate dosing pumps in a potentially explosive atmosphere if they do not have corresponding nameplates or an appropriate EC Declaration of Conformity for potentially explosive atmospheres.

#### 3.5 Prohibited dosing media

The dosing pump must not be used for these media and substances:

- Gaseous media,
- radioactive media,
- solid substances,
- flammable media, if adequate protective measures are not taken
- all other media that are not suitable for delivery using this dosing pump.

#### 3.6 Use in explosion risk areas

- The MEMDOS LB dosing pump with ATEX certification is an electric motor-driven, explosion protected Motor-driven Diaphragm Dosing Pump of equipment group II, equipment category 2G. When used with an explosion-protected motor, it is used to supply and dose fluids in zone 1 and 2 explosion risk areas.
- When using the dosing pumps in explosion risk areas, you must observe the minimum requirements concerning zoning. The explosion group, category and type of protection which is indicated in the labelling, must meet or be better than the requirements for the intended area of use.
- The operating instructions for the explosion protected motor which are included in delivery must also be observed.

### 3.6.1 Ex label of dosing pump and motor

Dosing pumps for use in zone 1 explosion risk areas carry the label:  
*II 2G ck IIC T4 - PTB 12 ATEX D036.*

Motors for use in zone 1 explosion risk areas carry the label:  
*II 2G Ex de IIC T4.*

Dosing pumps for use in zone 2 explosion risk areas carry the label:  
*II 2G ck IIC T4 - PTB 12 ATEX D036.*

Motors for use in zone 2 explosion risk areas carry the label:  
*II 2G Ex e IIC T3.*

This information can also be found on the ratings plate on the dosing pump (see „Ratings plate with ATEX label“ on page 12) and the ratings plate on the motor.

## 3.7 Foreseeable misuse

Below, there is information about the applications of the dosing pump or associated equipment that are not considered to be intended use. This chapter is intended to allow you to detect possible misuse in advance and to avoid it.

Foreseeable misuse is assigned to the individual stages of the product lifetime:

### 3.7.1 Faulty assembly

- Unstable or unsuitable bracket
- Dosing pump bolted wrongly or loosely

### 3.7.2 Faulty hydraulic installation

- Suction and pressure lines dimensioned incorrectly
- Unsuitable connection of the pipes due to wrong material or unsuitable connections.
- Suction and pressure lines mixed-up
- Damage to threads due to them being tightened too much
- Bending of pipelines
- No free return flow of the pressure relief valve
- Excessive demand due to the pressure differences between the suction and discharge valves
- Through-suction at installation without back-pressure valves
- Damage due to undamped acceleration mass forces
- Exceeding the admissible pressure on the suction and discharge sides
- Using damaged parts

### 3.7.3 Faulty electrical installation

- Connecting the mains voltage without a protective earth
- Unsecured mains or one that does not conform to standards
- Not possible to immediately or easily disconnect the power supply
- Wrong connecting cables for mains voltage
- Dosing pump accessories connected to wrong sockets
- Diaphragm monitoring not connected or defective
- Protective earth removed

### 3.7.4 Faulty commissioning

- Commissioning with damaged plant
- Shut-off valves closed at commissioning
- Closed suction or pressure line, e.g. due to blockages
- Personnel was not informed before commissioning
- System was recommissioned after maintenance without all the protective equipment and fixtures, etc. being reconnected.
- Inadequate protective clothing or none at all

### 3.7.5 Faulty operation

- Protective equipment not functioning correctly or dismantled
- Modification of the dosing pump without authority
- Ignoring operational disturbances
- Elimination of operational disturbances by personnel without adequate qualifications
- Deposits in the dosing head due to inadequate purging, particularly with suspensions
- Bridging the external fuse
- Operation made more difficult due to inadequate lighting or machines that are difficult to access
- Operation not possible due to dirty or illegible display of the dosing pump
- Delivery of dosing media for which the system is not designed
- Delivery of particulate or contaminated dosing media
- Inadequate protective clothing or none at all

### 3.7.6 Faulty maintenance

- Carrying out maintenance during ongoing operation
- Carrying out work that is not described in the operating instructions
- No adequate or regular inspection of correct functioning
- No replacement of damaged parts or cables with inadequate insulation
- No securing against reactivation during maintenance work
- Using cleaning materials that can cause reactions with the dosing media
- Inadequate cleaning of the system
- Unsuitable purging medium
- Unsuitable cleaning materials
- Cleaning materials left in system sections
- Using unsuitable cleaning equipment
- Using the wrong spares or lubricants
- Contaminating the dosing medium with lubricant
- Installing spares without following the instructions in the operating manual
- Blocking venting orifices
- Pulling off sections of the plant
- Contamination at installation without a dirt trap
- Mixing up the valves
- Mixing up the sensor lines
- Not reconnecting all the lines
- Damaging or not installing all the seals
- Not renewing seals
- Not paying attention to safety data sheets

- Inadequate protective clothing or none at all

### **3.7.7 Faulty decommissioning**

- Not completely removing the dosing medium
- Dismantling lines while the dosing pump is running
- Device not disconnected from the power supply
- Using the wrong dismantling tools
- Inadequate protective clothing or none at all

### **3.7.8 Faulty disposal**

- Incorrect disposal of dosing media, operating resources and other materials
- No labelling of hazardous substances

## 4 Product Description

### 4.1 Properties

The MEMDOS LB is a classic motor-driven diaphragm dosing pump. It is used when constant dosing is required without the use of a controller.

They are characterized by the following properties:

- Suitable for accurate mixing tasks.
- Performance range of 4 to 1020 l/h with a back pressure of 16 – 3 bar.
- Reproducible dosing precision of  $\pm 2\%$ .
- Stroke length manually adjustable between 0% and 100%.
- Suitable for use with frequency converters.
- Wide range of dosing head materials.
- With ATEX certification can be used in zones 1 and 2 explosion risk areas.
- Leak-free.
- Suitable for highly aggressive or poisonous dosing media.
- Fitted with a separating chamber which helps preventing uncontrolled dosing media escape in the event of a diaphragm rupture.

### 4.2 Scope of delivery

Please compare the delivery note with the scope of delivery. The following items are part of the scope of delivery:

- Dosing pump MEMDOS LB
- Operating instructions
- Motor operating instructions (only for MEMDOS LB dosing pumps with explosion protection motors)
- Inspection report and test certificate (optional)
- Accessory kits (optional)

### 4.3 Structure of the dosing pump

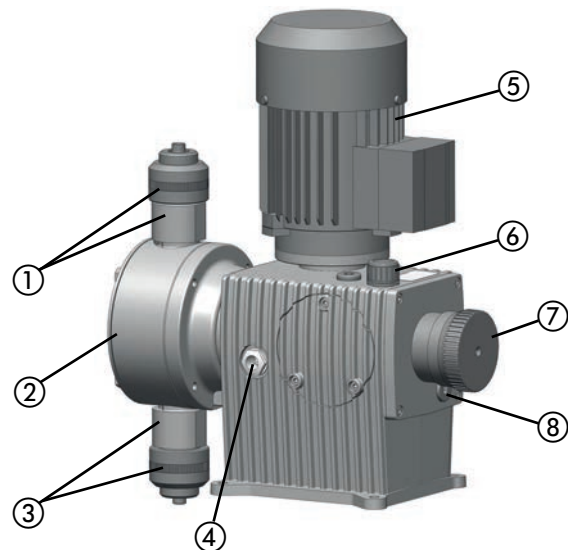

Fig. 4-1: Overview of MEMDOS LB dosing pump

No.	Description
①	Valve and connection on the discharge side
②	Dosing head
③	Valve and connection on the suction side
④	Oil level glass
⑤	Drive motor
⑥	Oil inlet and gearbox ventilation
⑦	Stroke length adjustment
⑧	Oil drain

Table 4-1: Designation of components

### 4.4 Function description

Dosing pumps are positive displacement pumps. They are used if precisely defined delivery of a medium is necessary. A constant volume per stroke or time is delivered.

The system delivers or meters the dosing medium by means of a repeated sequence of suction strokes followed by pressure strokes. This results in a pulsing flow.

If the dosing pump is in the suction stroke phase, the diaphragm is pulled into the rear final position. Due to the resulting vacuum in the dosing head, the discharge valve closes, the suction valve opens and dosing medium flows from the suction line into the dosing head.

If the dosing pump is in the pressure stroke phase, the diaphragm is moved into the front final position. Due to the pressure in the dosing head, the suction valve closes and the dosing medium flows through the discharge valve from the dosing head into the pressurised pipe.

#### 4.4.1 Ratings plate (type label)

There is information on the equipment about safety or the product's way of functioning. The information must stay legible for the duration of the service life of the product.

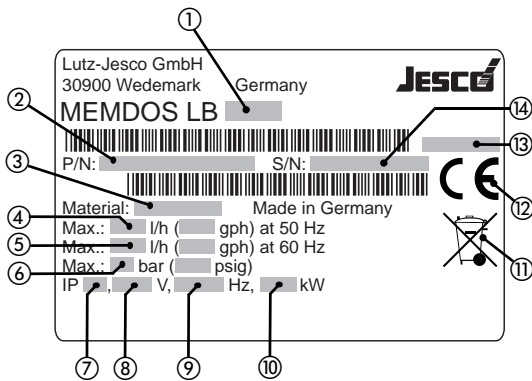

Fig. 4-2: MEMDOS LB ratings plate

No.	Description
①	Product, type, nominal size
②	Part number
③	Type of material of dosing head/ type of material of seals
④	Maximum delivery capacity in l/h and gph at 60 Hz frequency and maximum pressure
⑤	Maximum delivery capacity in l/h and gph at 50 Hz frequency and maximum pressure
⑥	Maximum pressure in bar and psig
⑦	Protection class
⑧	Voltage supply
⑨	Frequency

Table 4-2: Ratings plate

No.	Description
⑩	Power consumption
⑪	WEEE label
⑫	Label showing conformity with applicable European directives
⑬	Month / year of manufacture
⑭	Serial number

Table 4-2: Ratings plate

#### 4.4.2 Ratings plate with ATEX label

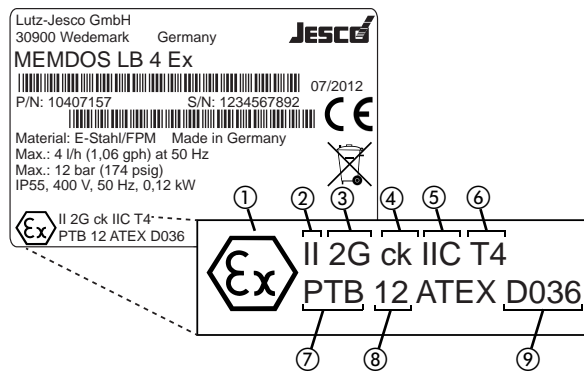

Fig. 4-3: Ratings plate MEMDOS LB with ATEX certificate

No.	Description
①	Specific EC labelling for protection against explosion risk
②	Device group
③	Device category
④	Degree of ignition protection
⑤	Explosion group
⑥	Temperature class
⑦	Inspecting authority
⑧	Year of issue
⑨	Certificate serial number

Table 4-3: Ratings plate with ATEX label

## 5 Technical specifications

### 5.1 Delivery capacity data

Please note that some of this data only represents guide values. The actual capacity of a dosing pump depends on various factors. For approximate values of the delivery capacity at different pressures, refer to Chapter "Delivery characteristic curves" (see page 49).

#### 5.1.1 MEMDOS LB 4 – 80, 150

Information	Value		MEMDOS LB size									
			4	4-HP	10	10-HP	20	20-HP	35	60	80	150
Delivery capacity at max. back pressure	l/h	50 Hz	4	8.4	14	24	22	36	36	63	90	156
		60 Hz	4.8	10.1	16.8	28.8	26.4	43.2	43.2	75.6	108	187.2
	ml/stroke	2.6	5.4	3.2	5.6	3.1	5.0	8.3	8.8	20.8	21.7	
Max. back pressure	bar		12	16	12	16	12	16	10	10	5	5
Max. stroke frequency	RPM	50 Hz	26	26	72	72	120	120	72	120	72	120
		60 Hz	31.2	31.2	86.4	86.4	144	144	86.4	144	86.4	144
Suction height for non-gassing media (with a filled suction line)	mWS		9	9	9	9	9	9	8	8	7	7

Table 5-1: Delivery capacity MEMDOS LB 4 – 80, 150

#### 5.1.2 MEMDOS LB 110, 160 – 1010

Information	Value		MEMDOS LB size								
			110	160	210	260	310	400	510	760	1010
Delivery capacity at max. back pressure	l/h	50 Hz	114	144	210	264	294	390	504	744	1020
		60 Hz	136.8	172.8	252	316.8	352.8	468	604.8	892.8	1224
	ml/stroke	19.8	20.0	36.5	36.7	51.0	54.2	158.5	163.2	158.9	
Max. back pressure	bar		10	10	10	10	8	6	4	4	3
Max. stroke frequency	RPM	50 Hz	96	120	96	120	96	120	53	76	107
		60 Hz	115.2	144	115.2	144	115.2	144	63.6	91.2	128.4
Suction height for non-gassing media (with a filled suction line)	mWS		7	7	6	6	4.5	4.5	1	1	1

Table 5-2: Delivery capacity MEMDOS LB 110, 160– 1010

## 5.2 Operating conditions and limits

Information	Value	MEMDOS LB (all sizes)
Permitted ambient temperature	°C	0 – 45 (0 – 40 with PVC parts)*
Relative humidity	%	Max. 90
Max. sound pressure level	dB(A)	57 – 65
Max. supply pressure	mbar	500
Viscosity limits	mPa s	300** / 1000***
Adjustable dosing range	%	0 – 100

Table 5-3: Operating conditions and limits

\*\* Use of dosing pumps at ambient temperatures of under 5 °C has to be checked individually. In those cases please contact the manufacturer.

\*\* With a viscosity of ~300 mPa s and above, you must use spring-loaded valves.

\*\*\* If the viscosity is above 1000 mPa s, this must be checked individually and the stroke frequency must be between 50 and 100 strokes/min.

### 5.2.1 Permitted media temperatures

Information	Value	MEMDOS LB (all sizes)
Dosing head made of PVC	°C	0 – 35
Dosing head made of PP	°C	0 – 60
Dosing head made of PVDF	°C	0 – 80
Dosing head made of stainless steel (1.4571)	°C	0 – 80

Table 5-4: Permitted media temperatures

## 5.3 Other data

### 5.3.1 MEMDOS LB 4 – 80, 150

Information	Value	MEMDOS LB size									
		4	4-HP	10	10-HP	20	20-HP	35	60	80	150
Weight (dosing head made of PVC, without motor*)	kg	4.5								5.9	
Weight (dosing head made of PP, without motor*)	kg	4.5								5.9	
Weight (dosing head made of PVDF, without motor*)	kg	4.8								7.5	
Weight (dosing head made of stainless steel (1.4571), without motor*)	kg	6								11.2	
Diameter of diaphragm	mm	52					64		90		
Stroke length	mm	7.5					10				

Table 5-5: Other data MEMDOS LB 4 – 80, 150

Information	Value	MEMDOS LB size									
		4	4-HP	10	10-HP	20	20-HP	35	60	80	150
Protection class		IP55									
Nominal valve width		DN4					DN6		DN10		

Table 5-5: Other data MEMDOS LB 4 – 80, 150

\*Weights of motors, see “Motor data” on page 16.

### 5.3.2 MEMDOS LB 110, 160 – 1010

Information	Value	MEMDOS LB size								
		110	160	210	260	310	400	510	760	1010
Weight (dosing head made of PVC, without motor*)	kg	9		9.8		11.5		13.6		
Weight (dosing head made of PP, without motor*)	kg	9		9.8		11.5		13.6		
Weight (dosing head made of PVDF, without motor*)	kg	9.6		10.7		13		16.2		
Weight (dosing head made of stainless steel (1.4571), without motor*)	kg	14.3		17.4		23.2		36		
Diameter of diaphragm	mm	90		120		150		185		
Stroke length	mm	10						12.5		
Insulation class		F								
Nominal valve width		DN10			DN15			DN25		

Table 5-6: Other data MEMDOS LB 110, 160 – 1010

\*Weights of motors, see “Motor data” on page 16.

## 5.4 Motor data

### 5.4.1 230 V AC / 120 V AC motors with operating capacitor

Information	Value	MEMDOS LB size			
		4 – 80, 150	110, 160 – 400	510 – 760	1010
Power output	kW	0.12	0,25	0.75	
Speed	RPM	1415 / 1698	1400 / 1680	1405 / 1686	
Nominal current	A	1 / 1,92	1,86 / 3,57	4,8 / 9,2	
Voltage	V 1~	230 / 120			
Mains voltage		DIN EC 60038			
Frequency	Hz	50 / 60			
Operating mode		S1			
Protection class		IP55			
Insulation class		F			
Size		63	71	80	80
Flange Diameter	mm	90	105	120	120
Shaft	mm	11 x 23	14 x 30	19 x 40	19 x 40
Cooling		IC 411			
Weight (230 V AC)	kg	4.1	7.5	8.8	10
Weight (120 V AC)	kg	4	6,4	10,5	10,5

Table 5-7: 230 V AC / 120 V AC motors with operating capacitor

### 5.4.2 400 V / 230 V three-phase motors

Information	Value	MEMDOS LB size			
		4 – 80, 150	110, 160 – 400	510 – 760	1010
Power output	kW	0.12	0.37	0.55	0.75
Speed	RPM	1400			
Nominal current	A	0.48	1.05	1.7	1.7
Voltage	V 3~	400 / 230			
Mains voltage		DIN EC 60038			
Frequency	Hz	50			
Operating mode		S1			
Protection class		IP55			
Insulation class		F			

Table 5-8: 400 V / 230 V three-phase motors

Information	Value	MEMDOS LB size			
		4 – 80, 150	110, 160 – 400	510 – 760	1010
Size		63	71	80	80
Flange Diameter	mm	90	105	120	120
Shaft	mm	11 x 23	14 x 30	19 x 40	19 x 40
Cooling		IC 411			
Weight	kg	3.5	6	8	9.4

Table 5-8: 400 V / 230 V three-phase motors

### 5.4.3 Three-phase motors in explosion protection versions

#### Motors for use in Zone 1 explosive risk areas

Information	Value	MEMDOS LB size			
		4 – 80, 150	110, 160 – 400	510 – 760	1010
Power output	kW	0.18	0.37	0.75	
Speed	RPM	1405	1390		
Nominal current	A	0.65	11	2.06	
Voltage	V 3~	230 / 400			
Mains voltage		DIN IEC 60038			
Frequency	Hz	50			
Operating mode		S1			
Protection class		IP55			
Insulation class		F			
Temperature class		T4			
Degree of ignition protection		de			
Ex label		II 2G Ex de IIC T4			
Size		63	71	80	
Flange Diameter	mm	90	105	120	
Shaft	mm	11 x 23	14 x 30	19 x 40	
Cooling		IC 411			
Weight	kg	9	19	26	

Table 5-9: Motors for use in Zone 1 explosive risk areas

**Motors for use in Zone 2 explosive risk areas**

Information	Value	MEMDOS LB size			
		4 – 80, 150	110, 160 – 400	510 – 760	1010
Power output	kW	0.12	0.37	0.55	0.75
Speed	RPM	1400	1420	1400	
Nominal current	A	0.41	1.14	1.51	
Voltage	V 3~	230 / 400			
Mains voltage		DIN IEC 60038			
Frequency	Hz	50			
Operating mode		S1			
Protection class		IP55			
Insulation class		F			
Temperature class		T3			
Degree of ignition protection		e			
Ex label		II 2G Ex e IIC T3			
Size		63	71	80	
Flange Diameter	mm	90	105	120	
Shaft	mm	11 x 23	14 x 30	19 x 40	
Cooling		IC 411			
Weight	kg	4.1	7.2	9.8	12.3

Table 5-10: Motors for use in Zone 2 explosive risk areas

## 5.5 Electric servomotors

Information	Value	MEMDOS LB Size			
		4 – 1010			
		Servomotor Type NL 0608		Servomotor Type NL 0608 PMR 2-LC	
Design		Reversible alternating current motor with maintenance-free gear, inside gear disengagement			
Use		For controllers with switching output (3-point step control)		For controllers with constant output 0(4) – 20 mA	
Voltage	V 1~	115	230	115	230
Frequency	Hz	50/60			
Power consumption	VA	Max. 20			
Torque	Nm	8			
Actuating time (switch actuation path 10 turns)	s	240 (50 Hz)			
		200 (60 Hz)			
Service switch		-	-	Manual/automatic operation	
Protection class		IP65 (with cable screw connections)			
Ambient temperature	°C	-15 to +60		0 to +60	
Weight	kg	3.4			
Shaft end	mm	d = 12 x 25 (with feather keyway)			
End-position limit		2 limit switches, adjustable by trigger cam			
<b>Inputs</b>					
Control		3-point step control		0(4) – 20 mA 0 – 10 V*	
Working resistance at 0(4) – 20 mA		-		250 Ω	
<b>Outputs</b>					
Position feedback signal for remote display		0 – 1000 Ω, max. 2 W		0(4) – 20 mA	

Table 5-11: Electric servomotors

\* Corresponding presetting available as an option or subsequently adjustable.



Please also follow the operating instructions for the electric servomotor enclosed with the dosing pump.

## 6 Dimensions

All dimensions in mm

### 6.1 MEMDOS LB 4 – 80, 150

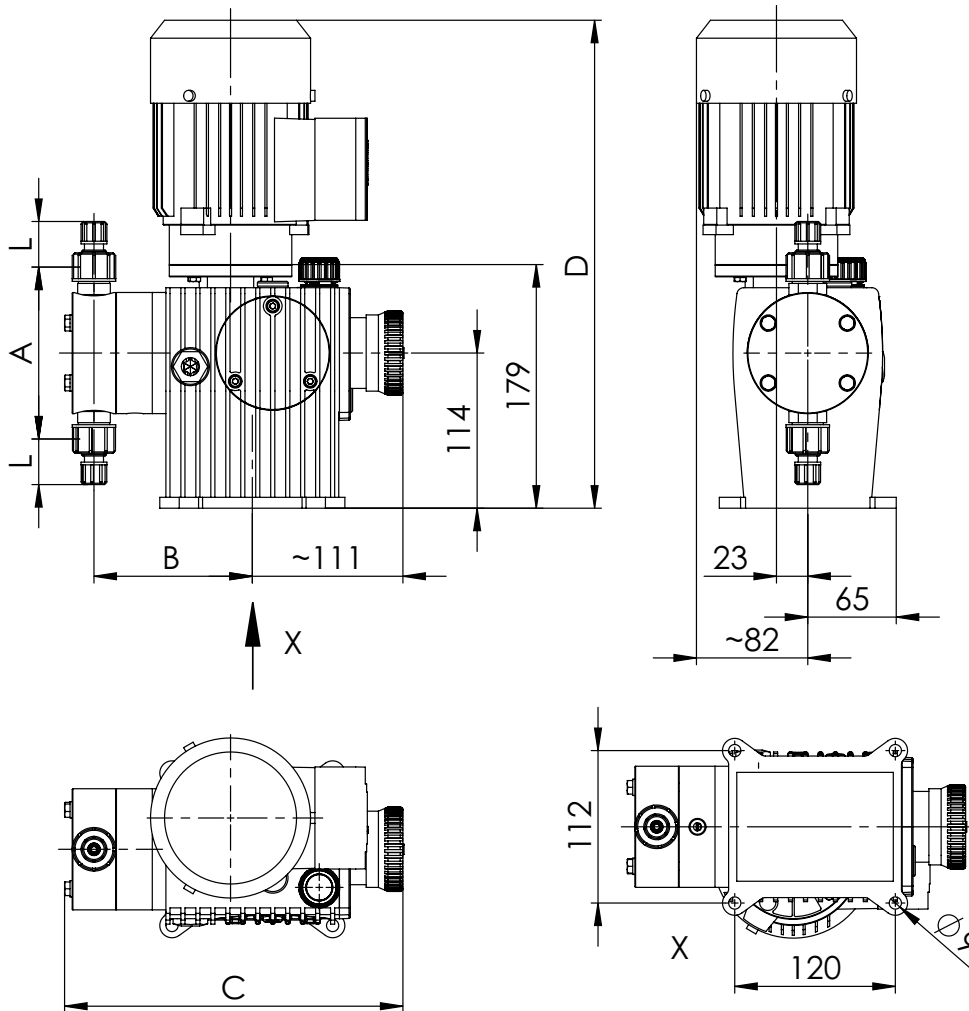

Fig. 6-1: Dimensioned drawings MEMDOS LB 4 – 80 and 150

Size	MEMDOS LB size		
	4 – 20	35 – 60	80, 150
A	126	149	249
B	116	121.5	133
C	249	256	280
D	389	389	389
L	Depends on the connection type and size		

6.2 MEMDOS LB 110, 160 – 1010

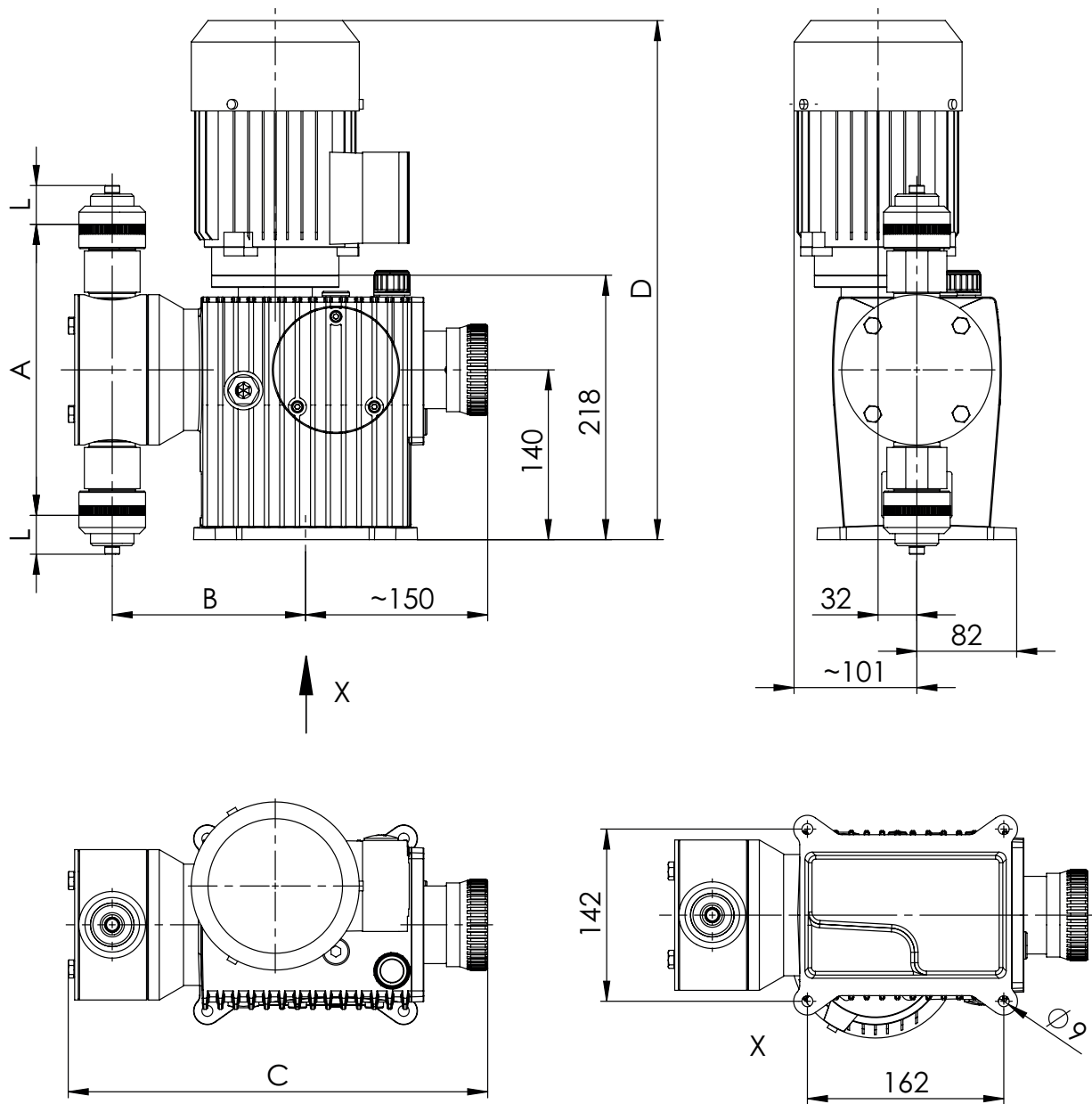

Fig. 6-2: Dimensioned drawings MEMDOS LB 110, 160 – 1010

Size	MEMDOS LB size			
	110, 160	210 – 260	310 – 400	510 – 1010
A	249	268	312.5	352
B	160	170	175	208 (194,3*)
C	346	357	362	402 (375,5*)
D	437	437	437	450
L	Depends on the connection type and size			

\* with dosing head made of stainless steel (1.4571)

### 6.3 MEMDOS LB 4 – 80, 150 with electric servomotor

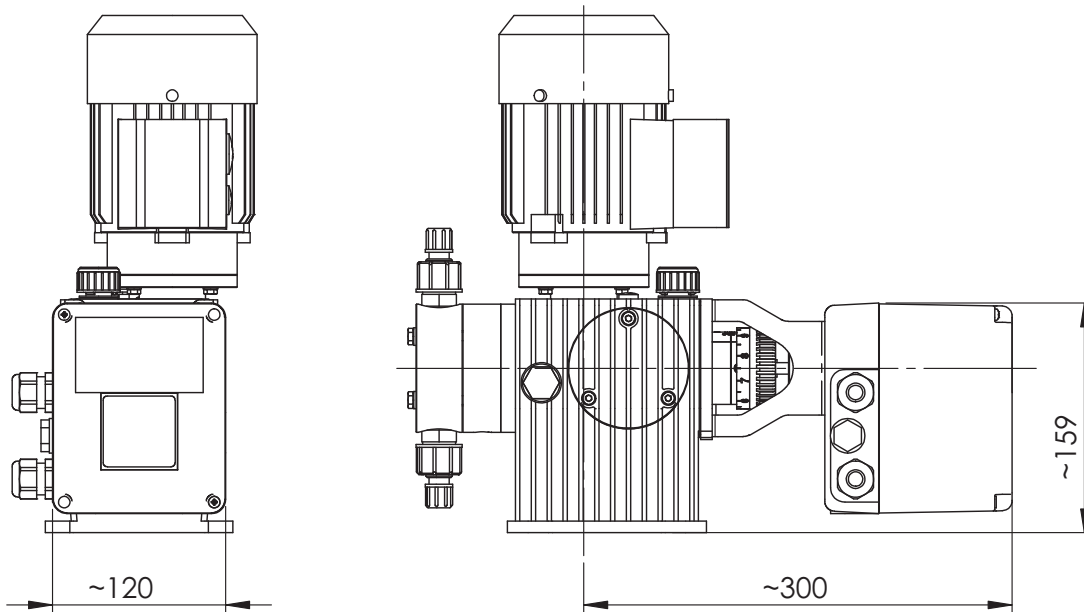

Fig. 6-3: Dimensioned drawings MEMDOS LB 4 – 80 and 150 with electric servomotor

### 6.4 MEMDOS LB 110, 160 – 1010 with electric servomotor

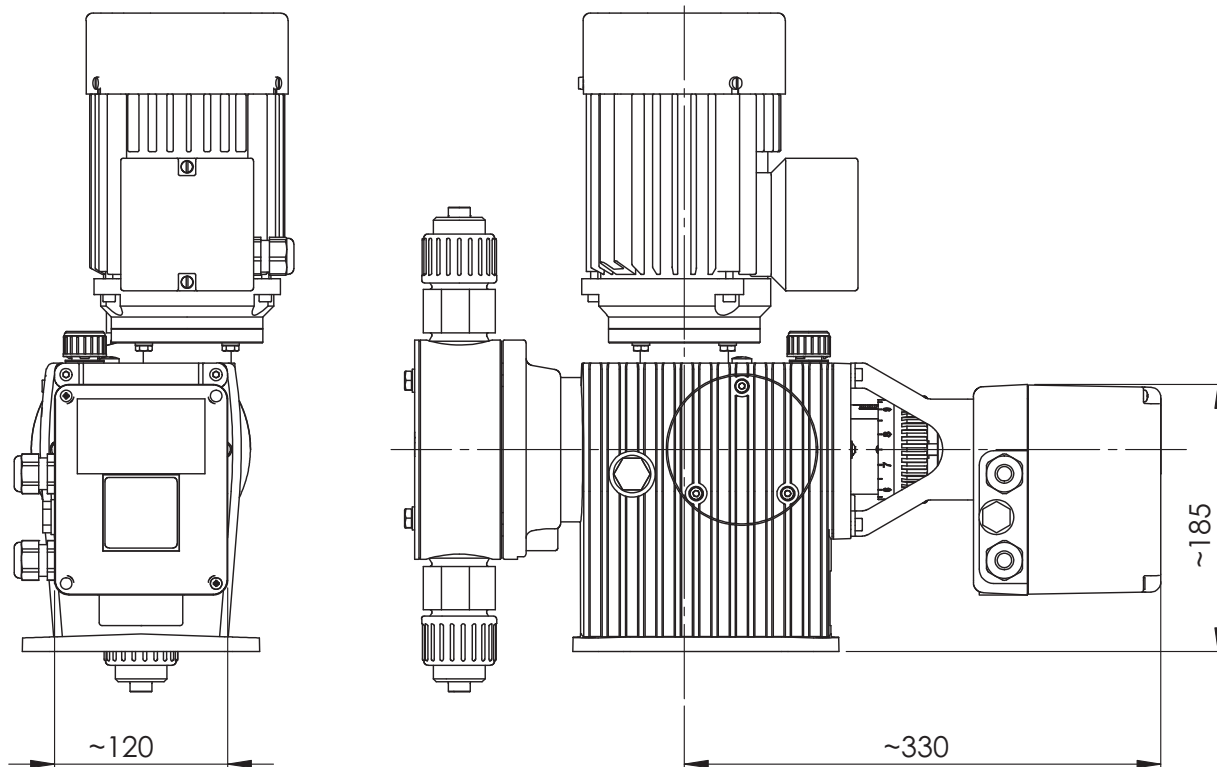



Fig. 6-4: Dimensioned drawings MEMDOS LB 110, 160 – 1010 with electric servomotor

## 7 Dosing pump installation

	DANGER!
<p><b>Danger to life due to electric shock</b></p> <p>Electrically conductive liquid can enter pump housings, cable screw connections and mains connectors.</p> <p>⇒ Make sure that all protective measures comply at least with the requirements of protection class IP55.</p> <p>⇒ Always set up the dosing pump such that water cannot enter the housing.</p>	
	CAUTION
<p><b>Danger of personal injury and material damage!</b></p> <p>A dosing pump that is difficult to access represents a danger due to incorrect operation and faulty maintenance.</p> <p>⇒ Install the dosing pump so that it is accessible at any time, in particular the stroke length adjustment, the oil level glass as well as the oil filler and drain.</p>	

### 7.2 Installation on a wall console

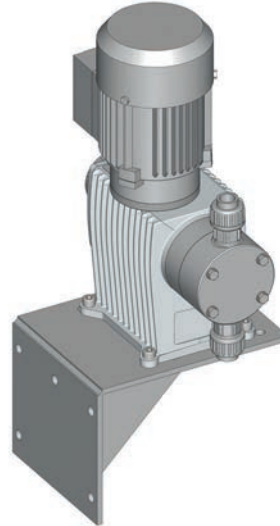

Fig. 7-1: Installation on a wall console

### 7.1 Set up information

When installing, follow the basic principles below:

- The valves must be vertical: Discharge valve at top, suction valve at bottom. Observe the arrows which are found on the valves. The dosing head and the valves must be oriented so that the arrows point vertically upwards.
- You should install the dosing pump at a convenient height for operation.
- It must not be fitted to a wall without a wall console.
- It must not be installed under the ceiling.
- The frame of foundation for fixing the dosing pump must not be subjected to jolts. The pump must be vibration-free and stable.
- There must be enough free space in the area of the dosing head and the suction and discharge valves for these parts to be easily dismantled if required. The entire space requirement for installation and maintenance is approximately 1 m<sup>2</sup>.
- The distance from the sides of the dosing pump to the wall or other dosing pumps or equipment must be at least 3 cm. There must be a guaranteed flow of circulating air.
- The maximum ambient temperature must be complied with, see "Operating conditions and limits" on page 14. If necessary, radiated heat from surrounding equipment must be screened.
- Avoid exposure to direct sunlight.
- The dosing pump is not intended for use out of doors unless appropriate protective measures have been taken to prevent dust and water from entering the housing.
- For the dimensions of the fastening holes, refer to Chapter "Dimensions" (see page 20).
- Install the dosing pump with the feet on a level surface.
- The tightening torque for the fastening bolts is 15 Nm.

## 8 Hydraulic installations

In this chapter, you will find information about the hydraulic parts of a system that you should install or that can install additionally. In many cases, you must install hydraulic accessories to be able to use all the functions that the dosing pump MEMDOS LB offers, to guarantee functional safety or to achieve a high level of dosing precision.

	<b>WARNING</b>
<p><b>Caustic burns or other burns through dosing media!</b></p> <p>The materials of the dosing pump and hydraulic parts of the system must be suitable for the dosing medium that is used. Should this not be the case, the dosing media may leak. Depending on the type and hazardousness of the dosing medium, this can result in injury.</p> <p>⇒ Make sure that the materials you are using are suitable for the dosing medium.</p> <p>⇒ Make sure that the lubricants, adhesives, sealants, etc. that you use are suitable for the dosing medium.</p>	

	<b>WARNING</b>
<p><b>Caustic burns or other burns through dosing media!</b></p> <p>If there is a diaphragm rupture, the dosing medium can escape in an uncontrolled way. Depending on the type and hazardousness of the dosing medium, this can result in injury.</p> <p>⇒ Install a leakage drain.</p>	

	<b>WARNING</b>
<p><b>Caustic burns or other burns through dosing media!</b></p> <p>The dosing pump can generate a pressure that is many times the rated one. A blocked pressure line can lead to dosing medium escaping. Depending on the type and hazardousness of the dosing medium, this can result in injury.</p> <p>⇒ Install pressure relief valves.</p>	

	<b>CAUTION</b>
<p><b>Danger of personal injury and material damage!</b></p> <p>High peak pressures can lead to piping vibrating and cause them to snap. This can result in injury due to uncontrollable piping or escaping dosing media.</p> <p>⇒ Install pulsation dampeners.</p>	

	<b>NOTICE</b>
<p><b>Damage to drives due to overloading</b></p> <p>The pressure conditions between the suction and discharge sides must be balanced; otherwise, overloading can result. This can lead to uncontrolled dosing processes, damage to the plant pipework and to the dosing pump.</p> <p>⇒ Ensure that the pressure on the discharge side is at least 1 bar greater than on the suction side.</p>	

	<b>NOTICE</b>
<p><b>Locking of threads (seized threads)</b></p> <p>Stainless steel and plastic parts (particularly those made of PVC) which are screwed together forming a detachable connection can seize (e.g. the dosing head and the valves).</p> <p>⇒ Before screwing together, grease the corresponding parts with a lubricant, e.g. PTFE spray). Ensure that the lubricant is compatible with the dosing medium.</p>	

Warning notice for installation in an explosive risk zone:

	<b>DANGER</b>
<p><b>Danger to life through explosions!</b></p> <p>Systems without a pressure relief valve fitted produce an increased safety risk in an explosive risk zone. Explosions could occur if system parts heat up during an overload or by sparks which may be created if drive parts were to break.</p> <p>⇒ Install a pressure relief valve on the pressure side of the dosing pump.</p>	

### 8.1 Design of the system

- The dosing pump's technical data (see „Technical specifications“ on page 13) must be taken into account and the plant's layout must be set up appropriately (e.g. pressure loss when rating the lines with regard to their nominal diameter and length).
- You must design the entire plant and its integrated dosing pump such that escaping dosing medium due to the failure of wearing parts such as the diaphragm, or to burst hoses does not lead to permanent damage to parts of the system or the premises.
- The leakage opening of the dosing head must be visible so that you can detect a diaphragm rupture. It must be possible for the outflow from the leakage drain to be on a free downwards gradient.
- If you use hazardous dosing media, the installation must be laid out that, even if the dosing pump fails, no disproportionately high consequential damage can occur.
- To avoid dosing errors at the end of the process, the dosing pump must be locked electrically and hydraulically.

- To allow you to easily inspect the pressure conditions in the system, you should provide connections for pressure gauges close to the suction and discharge valves.

### 8.2 System piping

- The system piping must not exert any force on the connections and valves of the dosing pump.
- This means that steel piping should be connected to the dosing pump via flexible pipe sections.
- The nominal diameters of the pipework and the installed fittings should be rated the same as or greater than the nominal diameters of the dosing pump's suction and discharge valves.
- The suction line should be kept as short as possible.
- You should avoid intertwined hoses.
- Avoid loops, since air bubbles can collect.

### 8.3 Suction and pressure valves

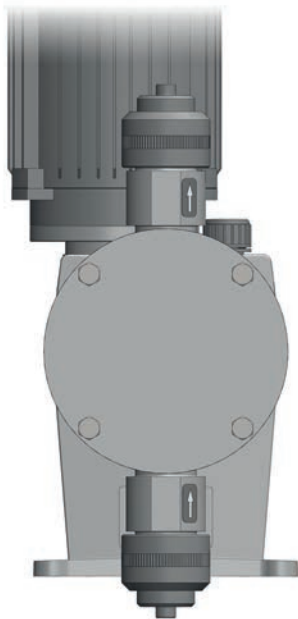

Fig. 8-1: Dosing head with suction and pressure valves

The suction and pressure valves are hydraulic connections to the dosing pump onto which the suction line or pressure line are attached.

These are double-ball bearing or spring-loaded valves which can only work properly when mounted in a vertical direction. The condition of the valves has a significant impact on the function and the dosing accuracy of the dosing pump.

All valves have arrows on them, these indicate the flow direction. These arrows must always point upwards.

For this reason, when connecting the dosing lines to the dosing pump, observe the alignment:

- Pressure valve above the dosing head,
- Suction valve under the dosing head.

### 8.4 Connecting a leakage drain

Lutz-Jesco GmbH dosing pumps are produced to the highest quality standards and have a long service life. However, some parts are subject to operational wear. This is the case particularly with the diaphragms that are continuously subjected to forces during the suction and discharge strokes and to the effects of the dosing medium.

If a diaphragm ruptures, the dosing medium starts to leak. This leakage is drained via the leakage opening. There is an opening on the dosing head's flange for this purpose.

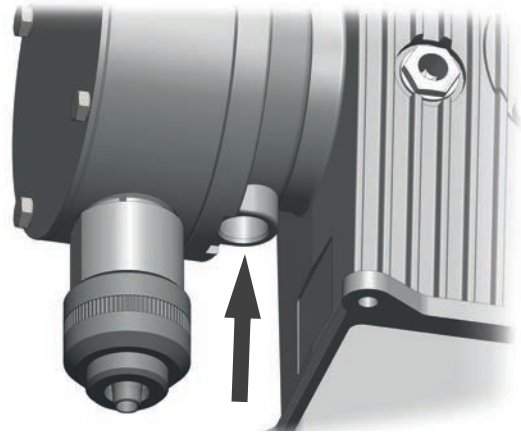

Fig. 8-2: Leakage drain opening

The use of a diaphragm rupture sensor is recommended.



#### DANGER

##### Danger to life through explosions!

If a diaphragm rupture sensor is installed in an explosive risk zone, sparks may be produced when the electrical circuit closes. Explosions may result which could result in fatal injuries.

⇒ Only use electrical or electronic devices which are intrinsically safe ignition protected.



#### NOTICE

##### Damage to drives due to effervescent media

If a hose is connected to the leakage drain and it is routed back into the dosing tank, effervescent media can enter the drive and damage it.

⇒ Collect the leakage in a collecting pan.

⇒ As an alternative, you can route the leakage back to the dosing tank using a funnel. You should install the funnel at an adequate distance from the leakage opening.

## 8.5 Hydraulic accessories

The following chapter is intended to give you an overview of installation options.

Please note that these operating instructions are no substitute for the instructions supplied with the accessories in each case. The corresponding documentation supplied with the product applies to safety information and provides exact instructions on assembly.

### 8.5.1 Injection nozzle

If the pressure line enters a main line, it is advisable to install an injection nozzle.

Injection nozzles have three main functions:

- Dosing the medium into a main line,
- Preventing flowback into the pressure line through a non-return valve.

Notes on assembly:

- Double-ball injection nozzles must be installed into the main line vertically from the bottom. You can install hose and spring-loaded injection nozzles any way you like.
- With dosing media that tend to crystallize, it is advisable to carry out installation into the main line from the bottom. This prevents air bubbles from being trapped.
- Many dosing media tend to contaminate the injection nozzles, which can lead to blockages. In cases like this, it is advisable to install an injection nozzle that is easy to dismantle and block off.

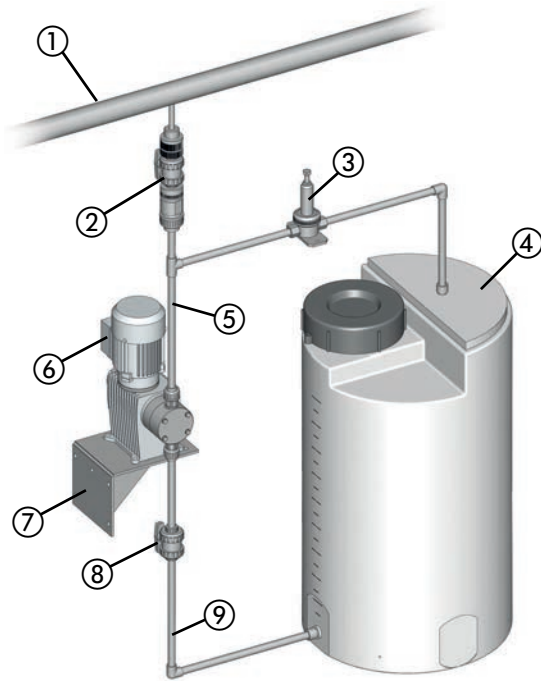

Fig. 8-3: Installation with an injection nozzle

No.	Description
①	Main line
②	Injection nozzle with shut-off valve
③	Pressure relief valve
④	Dosing tank
⑤	Pressure line
⑥	MEMDOS LB dosing pump
⑦	Wall bracket
⑧	Shutoff valve
⑨	Suction line

Table 8-1: Designation of components

### 8.5.2 Pressure relief valve

Pressure relief valves have an important safety function for protecting the dosing pump and the associated pipes and fittings. The dosing pump can generate a pressure that is many times the rated one. A blocked pressure line can lead to dosing medium escaping.

An inadmissibly high pressure can occur if:

- the shut-off valves are closed even though the dosing pump is running,
- pipes block.

At an appropriate pressure, a pressure relief valve opens a bypass line and protects the system in this way from pressures that are too high.

Notes on assembly:

- The line for returning dosing medium from the pressure relief valve must be routed to the dosing tank or to a collecting pan.
- The pressure in the dosing tank must not be too high so that it is possible to accommodate the returned dosing medium.
- As an alternative, the system can return dosing medium into the suction line in front of the dosing pump. In this case, there must not be a non-return valve or a foot valve in the suction line.
- You should install the pressure relief valve as close as possible to the dosing head.

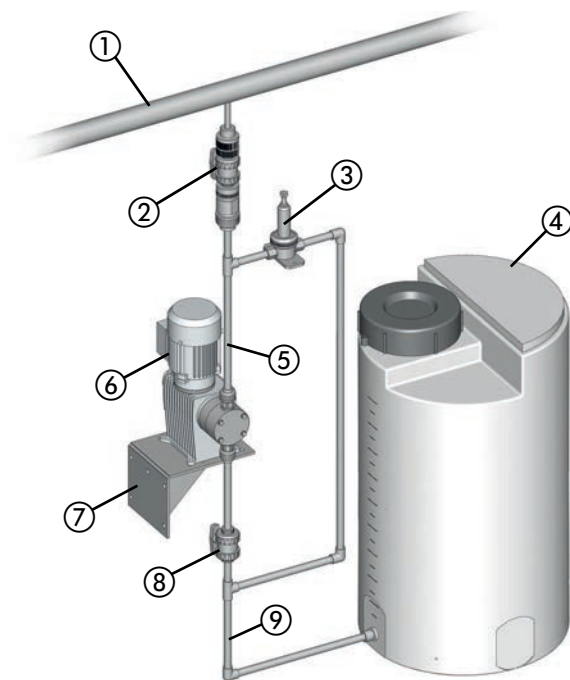

Fig. 8-4: Installation with pressure relief valve – returning to the suction line

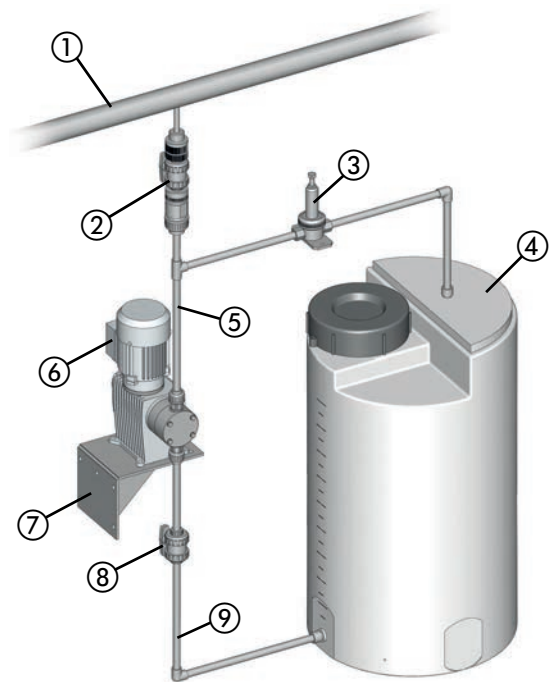

Fig. 8-5: Installation with pressure relief valve – returning to the dosing tank

No.	Description
①	Main line
②	Injection nozzle with shut-off valve
③	Pressure relief valve
④	Dosing tank
⑤	Pressure line
⑥	MEMDOS LB dosing pump
⑦	Wall bracket
⑧	Shutoff valve
⑨	Suction line

Table 8-2: Designation of components

### 8.5.3 Back-pressure valve

Back-pressure valves are necessary if:

- there are considerably fluctuating system pressures,
- the pressure on the suction side is higher than on the discharge side or if you intend to carry out dosing into depressurized lines.

In cases like this, if you do not use a back-pressure valve, imprecise dosing results will occur or overloading will result. The back-pressure valve solves these problems by generating a defined, constant back pressure.

In some circumstances, a back-pressure valve is unnecessary if you use a hose injection nozzle and if the back pressure that it generates is adequate.

No.	Description
①	Main line
②	Injection nozzle with shut-off valve
③	Back-pressure valve
④	Pressure relief valve
⑤	Dosing tank
⑥	Pressure line
⑦	MEMDOS LB dosing pump
⑧	Wall bracket
⑨	Shutoff valve
⑩	Suction line

Table 8-3: Designation of components

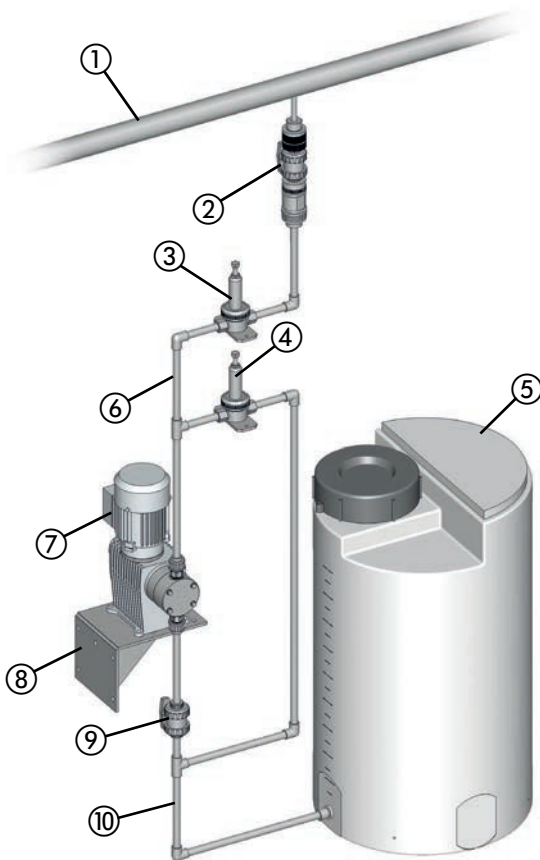

Fig. 8-6: Installation with a back-pressure valve

### 8.5.4 Pulsation dampener

Pulsation dampeners have the following functions:

- Damping pulsating delivery flows for processes that require low-pulsation dosing,
- Reducing the throughflow resistance with long pipelines.

When installed on the suction side:

- Damping of acceleration mass forces and with this reduction of wear on the dosing pump.
- Preventing cavitation (pull-off of the liquid column) due to too high acceleration.

However, pulsation dampeners also have important safety functions, since they prevent pressure peaks from arising that lead to piping vibrating and cause them to snap.

This problem can occur:

- with the high amplitudes of the vibrations,
- when using long pipes (the severity of the pulsation increases with the length of the pipe),
- when using rigid piping instead of elastic hoses.

Notes on assembly:

- You should carry out assembly in the direct vicinity of the location where you want to damp the pressure peaks (directly in front of the suction valve or directly behind the discharge valve).
- Pulsation dampeners should be installed with throttle valves or back-pressure valves installed directly behind them. By setting the valves appropriately, you can further-optimize damping of the pulsations.
- To prevent unnecessary pipe friction losses, you should lay the connecting line straight and in accordance with the rated width of the pulsation dampener.
- You must separately fasten relatively large pulsation dampeners and ones with hose connections.
- Pipelines must not transfer any mechanical tensions onto the pulsation dampener.

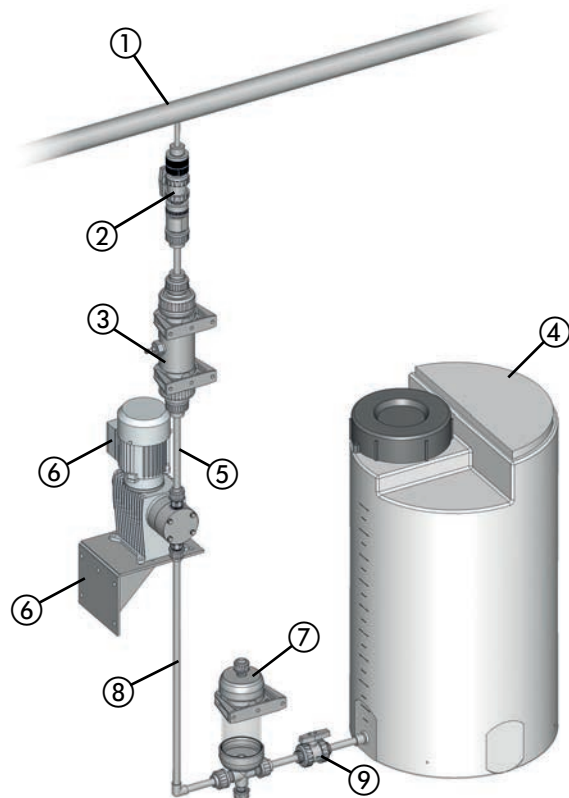

Fig. 8-7: Installation with a pulsation dampener

No.	Description
①	Main line
②	Injection nozzle with shut-off valve
③	Pulsation dampener
④	Dosing tank
⑤	Pressure line
⑥	MEMDOS LB dosing pump with wall console
⑦	Suction pulsation dampener
⑧	Suction line
⑨	Shutoff valve

Table 8-4: Designation of components

### 8.5.5 Priming aid

Priming aids are particularly advisable:

- in the case of dosing pumps with small volumetric displacements per stroke or with low stroke length settings,
- with high suction heads,
- with highly dense dosing media,
- at priming for the first time due to dry valves and air in the suction line and the dosing head,
- in dosing systems with frequent downtimes.

Further advantages resulting from priming aids:

- preventing cavitation in the suction line,
- gas removal,
- optical dosing control with small amounts,
- smoothing of the suction flow.

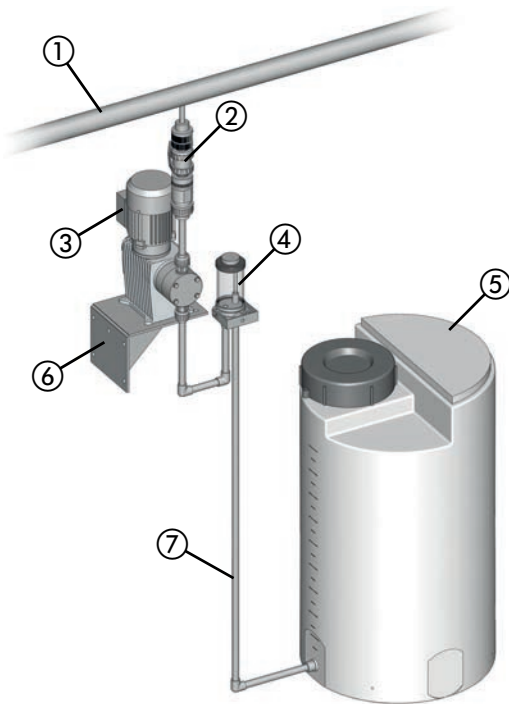

Fig. 8-8: Installation with a priming aid

No.	Description
①	Main line
②	Injection nozzle with shut-off valve
③	MEMDOS LB dosing pump
④	Priming aid
⑤	Dosing tank
⑥	Wall bracket
⑦	Suction line

Table 8-5: Designation of components

### 8.5.6 Dosing of suspensions

When dosing suspensions, the dosing head must be rinsed regularly to prevent depositing. To do this, you install a feed line for the rinsing medium (water) in the suction side installation.

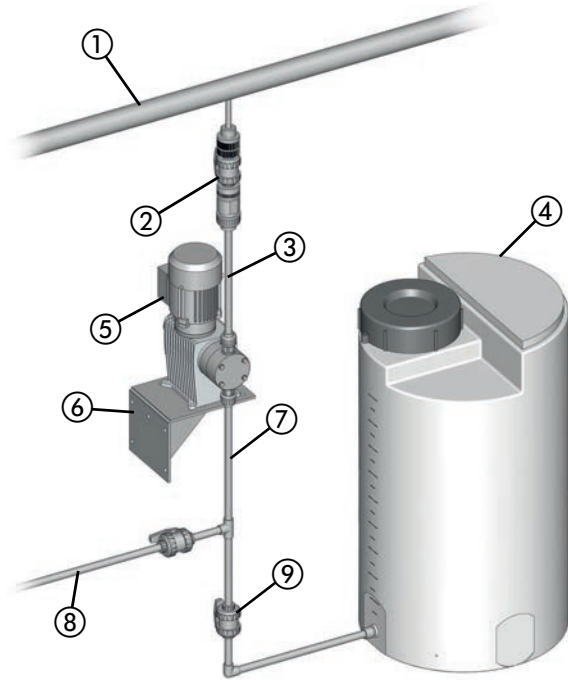

Fig. 8-9: Dosing of suspensions

No.	Description
①	Main line
②	Injection nozzle with shut-off valve
③	Pressure line
④	Dosing tank
⑤	MEMDOS LB dosing pump
⑥	Wall bracket
⑦	Suction line
⑧	Line for rinsing the dosing head
⑨	Shutoff valve

Table 8-6: Designation of components

### 8.5.7 Suction pressure regulator

A suction pressure regulator may be necessary if the suction-side installation of the system produces a varying suction pressure or supply pressure:

- Dosing pumps that are installed above dosing tanks deliver less as the tank empties, since the suction head increases.
- Dosing pumps that are installed below dosing tanks deliver less as the tank empties, since the positive delivery pressure reduces.

Further problems that can occur:

- Greater wear on the dosing pump, e.g. diaphragm rupture due to the effects of heavy forces with particularly high tanks and high-density dosing media.
- Idling of the dosing tank in the case of a diaphragm rupture or pipe breakage.
- Impermissibly high forces in the pump transmission that occur when dosing pumps receive the dosing medium directly from the pressure line.
- Reduced performance or destruction of fittings due to cavitation with long suction lines.

Installing a suction pressure regulator is a remedy for the problems above. The suction pressure regulator is opened by the dosing pump's suction pressure. This ensures that no dosing medium can flow if the dosing pump is not running or no vacuum can be generated following a pipe fracture.

Notes on assembly:

When using a large suction pressure regulator, you should provide a pulsation dampener on the suction side.

No.	Description
①	Main line
②	Injection nozzle with shut-off valve
③	Pressure line
④	Dosing tank
⑤	MEMDOS LB dosing pump
⑥	Wall bracket
⑦	Suction line
⑧	Suction pressure regulator
⑨	Shutoff valve

Table 8-7: Designation of components

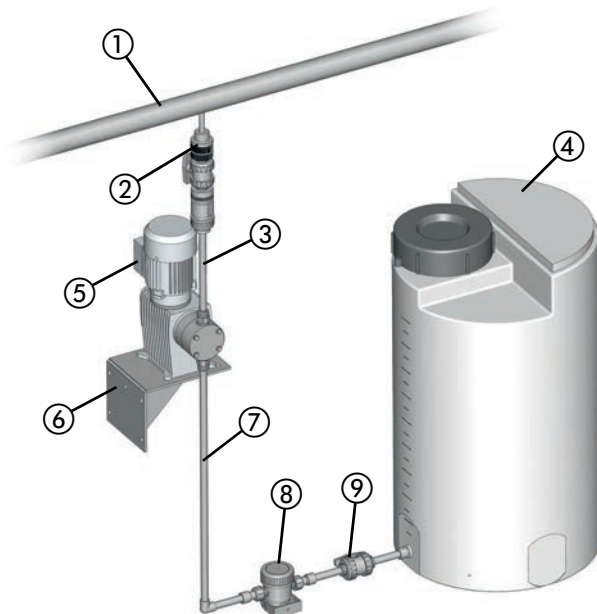

Fig. 8-10: Installation with a suction pressure regulator

## 9 Electrical installation

**DANGER**

**Danger to life due to electric shock**

If there is an electrical accident, you must disconnect the dosing pump from the mains as quickly as possible.

⇒ Install an emergency stop switch or integrate the dosing pump into the plant safety concept.

**DANGER**

**Increased risk of accidents due to insufficient qualification of personnel!**

Dosing pumps and their accessories may only be installed, operated and maintained by personnel with sufficient qualifications. Insufficient qualification will raise the risk of accidents.

⇒ The drive motor may only be connected by a qualified electrician.

⇒ Explosion protected motors in explosive protected areas may only be connected by qualified electricians with additional qualification for explosion protection.

**CAUTION**

**Danger of automatic start up!**

The dosing pump does not have an ON/OFF switch and may start to pump as soon as it is connected to the mains supply. This means that dosing medium can escape. Depending on the type and haz-ardousness of the dosing medium, this can result in damage to property or to injury.

⇒ Install an emergency stop switch or integrate the dosing pump into the plant safety concept.

**NOTICE**

**Gear wear**

If the rotational direction of the motor is not complied with, the gears can prematurely wear out.

⇒ Note the rotational direction arrow which is found on the motor and adjust the rotational direction accordingly.

**NOTICE**

**Damage due to wrong mains voltage**

The dosing pump can be damaged if you connect it to the wrong mains voltage.

⇒ Observe the information on the mains supply that is given on the nameplate.

Warning notice for installation in explosive risk areas:

**DANGER!**

**Danger to life through explosions!**

Explosions may result which could result in fatal injuries.

⇒ Earth the dosing pump, drive motor and all metal parts along the suction and pressure piping route.

### 9.1 Drive motor connection

- The electrical connection comply with local regulations.
- Cable type and cross-section of the supply lines must be chosen according to the motor data.
- We recommend using gland connections with strain-relief clamp.
- The required protection degree must be ensured by installing the connections professionally.
- The motor must be protected by a suitable motor protection switch.
- The dosing pump must be earthed via a PE conductor for the connection to the termination box.
- If an ATEX certified motor is being used, you must also observe the enclosed motor operating instructions.
- The motor must be connected to the termination box in accordance with the circuit diagram.

#### 9.1.1 Three-phase motors

Connection	Phases	MEMDOS LB
Star connection  	3~	4 – 1010
Delta connection  	3~	4 – 1010

Table 9-1: Three-phase motors circuit diagrams

### 9.1.2 AC motors

Connection	Phases	MEMDOS LB
<p>With right-turning motor:</p>	1~	4 – 1010
<p>With left-turning motor:</p>	1~	4 – 1010

Table 9-2: Three-phase motors circuit diagrams

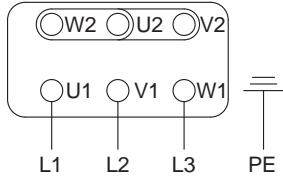
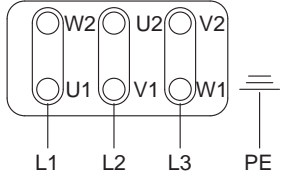
### 9.1.4 Connection of electric servomotor

Please follow the installation instructions in the operating instructions for the electric servomotor.

### 9.1.3 Rotational direction of the motor

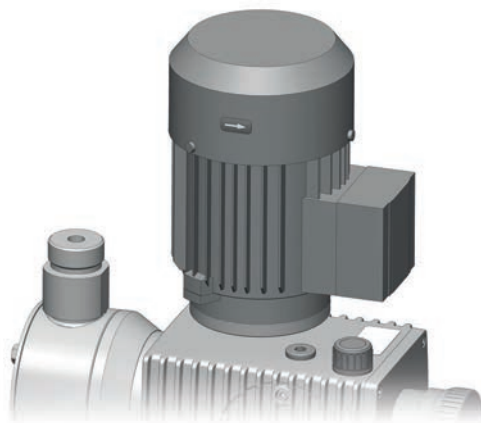

Fig. 9-1: Rotational direction arrow on the motor

The arrow indicates the rotational direction of the motor which should be set-up.

MEMDOS LB	Rotational direction*
<b>4 – 80, 150</b>	<i>Counter-clockwise</i>
<b>110, 160 – 1010</b>	<i>Clockwise</i>

\*Looking at the fan wheel

## 10 Control

### 10.1 Stroke length adjustment

The desired supply rate of the dosing pump is set using the stroke length adjustment. Turning the adjustment knob adjusts the hub length and so increases or decreases the amount of dosing media from the dosing head.

The stroke length can be adjusted while the pump is running or while it is turned off (in depressurized condition).

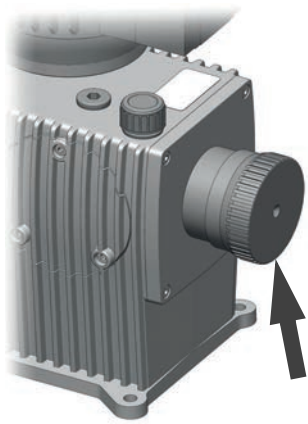

Fig. 10-1: Stroke length adjustment

Rotational direction*	Effect
<i>Clockwise</i>	Stroke length is reduced, supply rate decreases
<i>Counter-clockwise</i>	Stroke length is raised, supply rate increases

\*Looking at the stroke length adjustment

The scale on the stroke length adjustment shows the value of the setting in percentage terms from 0% (stopped) to 100% (maximum possible stroke length).

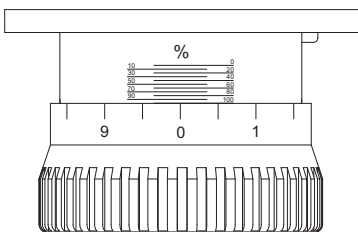





Fig. 10-2: Stroke adjustment scale

## 11 Operation

	<b>WARNING</b>
<p><b>Caustic burns or other burns through dosing media!</b></p> <p>After connecting the mains supply, residual dosing media in the dosing head can spray out.</p> <ul style="list-style-type: none"> <li>⇒ Before connecting the mains supply, connect the dosing lines.</li> <li>⇒ Check that all the screw connections have been tightened correctly and are leak-proof.</li> </ul>	

	<b>WARNING</b>
<p><b>Caustic burns or other burns through dosing media!</b></p> <p>While working on the dosing head, valves and connections, you may come into contact with dosing media.</p> <ul style="list-style-type: none"> <li>⇒ Use sufficient personal protective equipment.</li> <li>⇒ Rinse the dosing pump with a liquid (e.g. water) which does not pose any risk. Ensure that the liquid is compatible with the dosing medium.</li> <li>⇒ Release pressure in hydraulic parts.</li> <li>⇒ Never look into open ends of plugged pipelines and valves.</li> </ul>	

	<b>CAUTION</b>
<p><b>Danger of personal injury and material damage!</b></p> <p>Dosing medium can escape if you loosen connections on the dosing head, e.g. for venting, during operation.</p> <ul style="list-style-type: none"> <li>⇒ Follow the safety data sheet of the dosing medium.</li> <li>⇒ Clean the dosing pump if dosing medium escapes.</li> <li>⇒ Dispose of the dosing medium correctly.</li> </ul>	

	<b>CAUTION</b>
<p><b>Increased risk of accidents due to insufficient qualification of personnel!</b></p> <p>Dosing pumps and their accessories may only be installed, operated and maintained by personnel with sufficient qualifications. Insufficient qualification will raise the risk of accidents.</p> <ul style="list-style-type: none"> <li>⇒ Ensure that all action is taken only by personnel with sufficient and corresponding qualifications.</li> <li>⇒ Prevent access to the system for unauthorised persons.</li> </ul>	

	<b>CAUTION</b>
<p><b>Danger of personal injury and material damage!</b></p> <p>Changing dosing media can lead to unpredictable reactions.</p> <ul style="list-style-type: none"> <li>⇒ Thoroughly clean the dosing pump and appropriate sections of the plant to avoid chemical reactions.</li> </ul>	

	<b>CAUTION</b>
<p><b>Danger of personal injury and material damage!</b></p> <p>The dosing pump does not have an ON/OFF switch and may start to pump as soon as it is connected to the mains supply. This means that dosing medium can escape. Depending on the type and hazardness of the dosing medium, this can result in injury.</p> <ul style="list-style-type: none"> <li>⇒ Set the stroke length setting to 0 % before connecting the power supply.</li> <li>⇒ Ensure that the dosing pump has been installed correctly before connecting it to the mains supply.</li> </ul>	

	<b>NOTICE</b>
<p><b>Overheating of the motor</b></p> <p>If the fan cover is removed or is defective, insufficient motor cooling is provided.</p> <ul style="list-style-type: none"> <li>⇒ Before starting the dosing pump, ensure that the motor fan cover is fitted and fully functional.</li> </ul>	

## 11.1 Commissioning the dosing pump

Precondition for action:

- ✓ The dosing pump has been assembled and installed in accordance with chapter "Dosing pump installation" (see page 23), chapter "Hydraulic installations" (see page 24) and chapter "Electrical installation" (see page 32).
- ✓ All the mechanical fastenings have been inspected to ensure adequate load-bearing capacity.
- ✓ The dosing head screws have been tightened with the correct torque (see „Tighten dosing head bolts“ on page 40).
- ✓ All the hydraulic sections have been inspected to ensure they are adequately leak-proof and that the through flow direction is correct.
- ✓ The drive motor and all associated additional equipment is checked for proper connection.
- ✓ Personnel have read all the operating instructions and understood them completely.
- ✗ You need gear oil of viscosity class ISO-VG460 according to DIN 51519 (corresponds to SAE 140 according to DIN 51512).

Perform the following working steps:

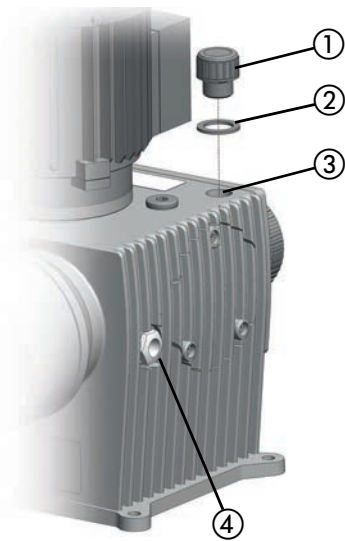

Fig. 11-1: Dosing pump oil inlet

1. Unscrew the closing screw ① from the oil inlet ③ and remove the washer seal ②.
2. Fill up with oil into the oil inlet ③. At the same time, check the oil level in the oil level glass ④. The oil level should reach approximately the middle of the oil level glass.

The following volumes are required:

MEMDOS LB	Filling volumes
4 – 80, 150	0.25 l
110, 160– 1010	0.75 l

3. Place the washer seal ② onto the oil inlet ③ and tighten up the closing screw ①.

4. Open the shut-off valves on the suction and discharge sides if present.



For initial commissioning, it is advisable to use water as the dosing medium to check that the system is leak-proof and that the dosing pump is functioning correctly. Check first whether undesirable reactions could occur between the actual dosing medium and the water.

At initial commissioning, it is advisable to prime the pump without back pressure. For this purpose, we recommend installing a relief valve on the discharge side of the dosing pump.

5. Connect the dosing pump to the power supply.
  - ▶ The dosing pump is ready for use.
6. Turn the stroke length adjustment slowly counter-clockwise until the dosing pump draws in enough and dosing starts.

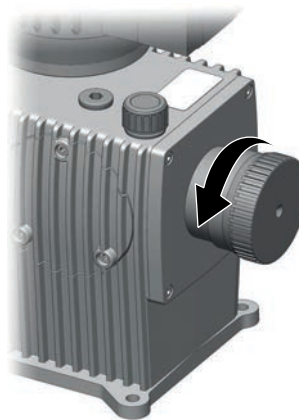

Fig. 11-2: Stroke length adjustment



If the dosing pump does not draw or draws insufficiently, the use of hydraulic accessories, such as priming aids, is recommended. See also "Hydraulic accessories" on page 26.

7. Calibrating the dosing pump. For an initial approximation, refer to the dosing supply diagrams (see „Delivery characteristic curves“ on page 49).

- ✓ **The dosing pump is commissioned.**

## 11.2 Commissioning the electric servomotor

MEMDOS LB dosing pumps with electric servomotor are supplied pre-assembled and mechanically pre-configured. The limit switches of the electric servomotor do not require adjustment.

The electric servomotor should only be adjusted if the dosing pump is in operation.

Precondition for action:

- ✓ The dosing pump has been assembled and installed in accordance with chapter "Dosing pump installation" (see page 23), chapter "Hydraulic installations" (see page 24) and chapter "Electrical installation" (see page 32).
  - ✓ The dosing pump was commissioned in accordance with chapter "Commissioning the dosing pump" (see page 36).
  - ✓ The electric installation of the servomotor was carried out in accordance with the associated operating instructions.
1. Connect the servomotor with the regulating equipment.
  2. Put the regulating equipment into operation.
  3. Adjust the control parameters for the electric servomotor in accordance with the system requirements.
- ✓ **Electric servomotor commissioned.**

## 11.3 Decommissioning the dosing pump

Perform the following working steps:

1. Set the stroke length adjustment to 0 %.
  2. Disconnect the dosing pump from the power supply.
  3. Disconnect all electrical connections.
  4. Depressurize all the hydraulic parts in the system.
  5. Unplug all the hydraulic connections on the dosing pump.
  6. Empty the dosing head.
  7. Remove any residual dosing medium from the dosing head by flushing the system with a washing agent. Ensure that the washing agent is compatible with the dosing medium.
- ✓ **Dosing pump is decommissioned.**

## 11.4 Shutting down in an emergency

- In an emergency, you must immediately disconnect the dosing pump from the mains supply or activate the Emergency Stop switch installed in the plant.
- Depending on the type of incident, you must depressurized the hydraulic connections or locked to prevent dosing medium from escaping.
- You must follow the safety data sheet of the dosing medium.

## 11.5 Storage

Storing the dosing pump correctly extends its service life. You should avoid negative influences like extreme temperatures, high humidity, dust, chemicals, etc.

Ensure ideal storage conditions where possible:

- the storage place must be cold, dry, dust-free and generously ventilated,
- Temperatures between + 2 °C and + 40 °C (with PP and PVDF dosing heads, between + 2 °C and + 60 °C),
- Relative humidity must not exceed 90%.

## 11.6 Transportation



### NOTICE

#### Machine damage caused by leaking oil

The oil inlet at the dosing pump cannot be closed completely tightly. Oil may leak if the device is not transported in an upright position. This might cause damage to the control unit or the motor.

⇒ Drain the oil completely through the oil outlet before you transport the dosing pump.

Perform the following working steps:

- The unit should be thoroughly cleaned. Any dangerous dosing media must be additionally neutralised and decontaminated.
- All accessories should be dismantled.
- All openings should be closed, so that no foreign objects can get into the system.
- The dosing pump must be suitably packed, preferably in the original packing, for transportation.

Should the unit be sent back to the manufacturer, please follow chapters "Declaration of harmlessness" (see page 53) and "Warranty application" (see page 55).

## 11.7 Disposal of old units

- The waste unit must be thoroughly cleaned. Any dangerous dosing media must be additionally neutralised and decontaminated.
- Any residual dosing media must be removed in a professional manner.
- The dosing pump must be disposed of in accordance with applicable local laws and regulations. The unit does not belong to household waste!
- As the disposal regulations may differ from country to country in the European Union, please consult your supplier if necessary.

## 12 Maintenance

Lutz-Jesco dosing pumps are produced to the highest quality standards and have a long service life. Nevertheless, some of their parts are subject to wear due to operation (e.g. diaphragms, valve seats, valve balls). This means that regular visual inspections are necessary to ensure a long operating life. Regular maintenance will protect the dosing pump from operation interruptions.

	<b>DANGER</b>
<p><b>Danger to life due to electric shock</b></p> <p>Live parts can inflict fatal injuries.</p> <ul style="list-style-type: none"> <li>⇒ Before carrying out any maintenance work, always disconnect the dosing pump from the power supply.</li> <li>⇒ Secure the dosing pump from accidental power-up.</li> <li>⇒ The protective conductor (earth) may only be removed during the last step.</li> <li>⇒ After maintenance work, all earthing measures must be restored.</li> </ul>	

	<b>WARNING</b>
<p><b>Caustic burns or other burns through dosing media!</b></p> <p>While working on the dosing head, valves and connections, you may come into contact with dosing media.</p> <ul style="list-style-type: none"> <li>⇒ Use sufficient personal protective equipment.</li> <li>⇒ Rinse the dosing pump with a medium (e.g. water) which does not pose any risk.</li> <li>⇒ Release pressure in hydraulic parts.</li> <li>⇒ Never look into open ends of plugged pipelines and valves.</li> </ul>	

	<b>WARNING</b>
<p><b>Caustic burns or other burns through dosing media!</b></p> <p>After connecting the mains supply, residual dosing media in the dosing head can spray out.</p> <ul style="list-style-type: none"> <li>⇒ Before connecting the mains supply, connect the dosing lines.</li> <li>⇒ Check that all the screw connections have been tightened correctly and are leak-proof.</li> </ul>	

	<b>CAUTION</b>
<p><b>Danger of personal injury and material damage!</b></p> <p>The dosing pump can generate a pressure that is many times the rated one. The dosing medium can escape in the case of material failure or wear on the dosing head, the connection pipe or the seals that are used.</p> <ul style="list-style-type: none"> <li>⇒ Carry out maintenance work at the recommended intervals.</li> </ul>	

	<b>CAUTION</b>
<p><b>Increased risk of accidents due to insufficient qualification of personnel!</b></p> <p>Dosing pumps and their accessories may only be installed, operated and maintained by personnel with sufficient qualifications. Insufficient qualification will raise the risk of accidents.</p> <ul style="list-style-type: none"> <li>⇒ Ensure that all action is taken only by personnel with sufficient and corresponding qualifications.</li> <li>⇒ Prevent access to the system for unauthorised persons.</li> </ul>	

The following warnings apply exclusively for explosive risk areas:

	<b>DANGER</b>
<p><b>Danger to life through explosions!</b></p> <p>Sparks may be formed during repair work by contact between tools or components.</p> <ul style="list-style-type: none"> <li>⇒ Only use tools which are suitable for use in explosive risk zones 1 and 2.</li> </ul>	

	<b>DANGER</b>
<p><b>Danger to life through explosions!</b></p> <p>Friction in parts of the dosing pump or system which are made of non-conducting plastic, can cause electrostatic charging.</p> <ul style="list-style-type: none"> <li>⇒ Clean plastic parts carefully with a damp cloth.</li> </ul>	

	<b>DANGER</b>
<p><b>Danger to life through explosions!</b></p> <p>The dosing pump can run hot if there is not enough oil. This could result in explosions occurring in explosive risk areas.</p> <ul style="list-style-type: none"> <li>⇒ Regularly check the oil level.</li> <li>⇒ If oil is leaking, the leak must be immediately fixed and the dosing pump taken out of operation.</li> </ul>	

## 12.1 Maintenance intervals

This table gives you an overview of maintenance work and the intervals at which you must carry it out. The next few chapters contain instructions for carrying out this work.

Maintenance work to be carried out	Frequency
Check the oil level in the oil level glass	■ Regularly
Change the oil	<ul style="list-style-type: none"> <li>■ Change the first filling after 5,000 operating hours or 1 year, whichever comes first.</li> <li>■ A further oil change after 10,000 operating hours or 2 years, whichever comes first.</li> </ul>
Check that piping is seated firmly	■ Regularly
Check that suction and discharge valves are seated firmly	■ Regularly
Clean suction and discharge valves	■ Regularly
Check that electrical connections are not damaged	■ Regularly
Tighten up dosing head bolts	<ul style="list-style-type: none"> <li>■ Regularly</li> <li>■ Before initial commissioning</li> <li>■ After each diaphragm change</li> </ul>
Check diaphragm for leakage due to rupture	■ Regularly (as long as no leak monitoring system is installed)
Check the dosing pump for unusual noises during operation, unusual temperatures or smells	■ Regularly
Replace wearing parts (diaphragms, bearings etc.)	■ When unacceptable levels of wear are detected
Rinse out and clean the dosing pump	<ul style="list-style-type: none"> <li>■ Before taking out of service for a long period of time</li> <li>■ After feeding aggressive, sticky, crystallising or contaminated liquids</li> </ul>
Checking the electric servomotor	■ Regularly
Lubricating the electric servomotor	■ not necessary, as it is lubricated for life

Table 12-1: Maintenance information and maintenance intervals

## 12.2 Change the oil

Precondition for action:

- ✓ A suitable oil collecting tank is held ready.
- ✳ You need gear oil of viscosity class ISO-VG460 according to DIN 51519 (corresponds to SAE 140 according to DIN 51512).

Perform the following working steps:

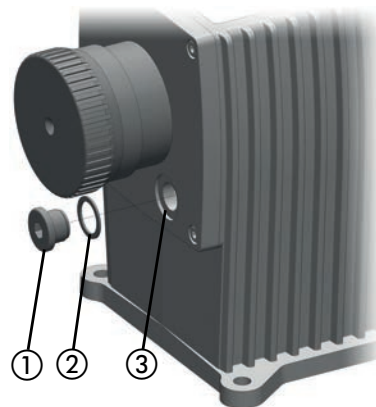

Fig. 12-1: Draining oil on the dosing pump

1. Unscrew the closing screw ① from the oil drain ③ and remove the washer seal ②.
2. Let all of the gear oil drain from the housing.
3. Place the washer seal ② onto the oil drain ③ and tighten up the closing screw ①.

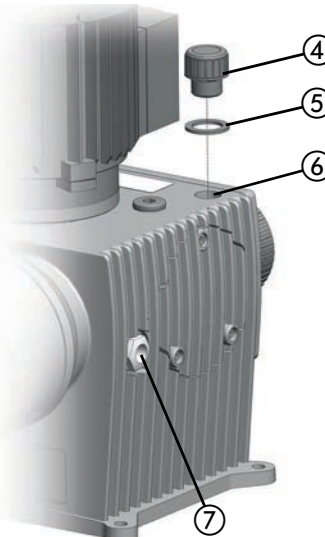

Fig. 12-2: Dosing pump oil inlet

4. Unscrew the closing screw ④ from the oil inlet ⑥ and remove the washer seal ⑤.

- Fill up with oil into the oil inlet (6). At the same time, check the oil level in the oil level glass (7). The oil level should reach approximately the middle of the oil level glass.

The following volumes are required:

MEMDOS LB	Filling volumes
4 – 80, 150	0.25 l
110, 160 – 1010	0.75 l

- Place the washer seal (5) onto the oil inlet (6) and tighten up the closing screw (4).

✓ **Oil change complete.**

### 12.3 Tighten dosing head bolts

	NOTICE
<p><b>Damage to the dosing head/leakiness of the diaphragm</b></p> <p>If you tighten the screws too much, this can lead to the dosing head being damaged. However, not tightening the screws enough leads to the diaphragm being leaky and correct functioning being affected.</p> <p>⇒ Tighten up the screws to a suitable torque, in accordance with the following table.</p>	

The torque needed for each MEMDOS LB type or the diaphragm size:

MEMDOS LB	Membrane diameter	Torque (+/- 10%)
4 – 20	52 mm	2 Nm
4-HP – 20-HP	52 mm	3 Nm
35 – 60	64 mm	3 Nm
80 – 160	90 mm	6 Nm
210 – 260	120 mm	6 Nm
310 – 400	150 mm	10 Nm
510 – 1010	185 mm	12 Nm

Table 12-2: Dosing head bolt torque

### 12.4 Diaphragm replacement

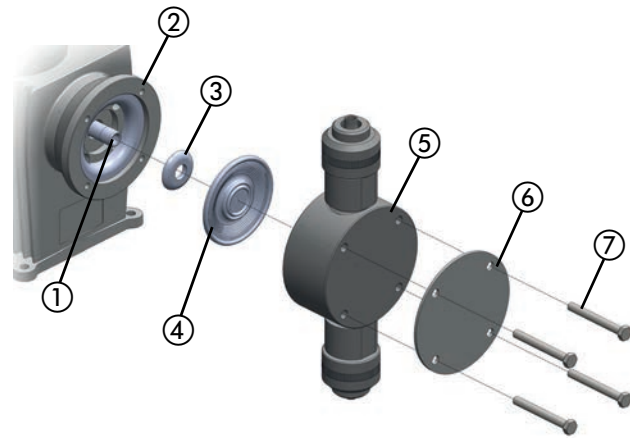

Fig. 12-3: Diaphragm replacement

#### 12.4.1 Remove the old diaphragm

Precondition for action:

- ✓ The stroke length adjustment is set to 0% with the motor running (this makes the diaphragm move to the front end position and you can remove it more easily).
- ✓ The dosing pump is disconnected from the power supply.
- ✓ The hydraulic parts of the system are depressurised.
- ✓ The dosing pump has been rinsed out with a non-hazardous medium (e.g. water).

Perform the following working steps:

- Unscrew the four bolts (7) on the dosing head with a suitable tool and remove the pressure plate (6) (only for MEMDOS LB 80 - 1010 with dosing heads made of PP, PVC and PVDF) and the dosing head (5).
- Bend up the diaphragm (4) slightly on the edge, hold it with pliers and screw it out counter-clockwise.
- Dosing pumps MEMDOS LB 4 - 60 contain an additional support plate (3), which sits behind the diaphragm. Remove the support plate.

#### 12.4.2 Install a new diaphragm

Precondition for action:

- ✓ The diaphragm rod (1), diaphragm flange (2) and, if present, the support plate (3) are thoroughly cleaned to prevent the new diaphragm being affected by any dosing media residue.
  - ✓ The diaphragm thread (4) is lightly greased (e.g. Molykote Longterm W2).
- The support plate (3) is pushed onto the threaded supports with the curved side facing the diaphragm.
  - Screw the diaphragm (4) together with the support plate (3) clockwise until it is securely fitted onto the membrane rod.
  - Place the dosing head (5) and the pressure plate (6) (only with the MEMDOS LB 80 - 1010 with PP, PVC, PVDF dosing heads) and insert the four bolts (7).

4. First tighten the screws finger-tight. After this, tighten the screws in diagonally opposite sequence, e.g. top left and bottom right and top right and bottom left.

✓ **Diaphragm change finished.**

## 12.5 Clean suction and pressure valves

Contaminated valves affect the dosing precision and this means that you should clean the valves on a regular basis.

 Suction and pressure valves differ in the sequence of assembly of the individual parts. Disassemble them one at a time to prevent parts being mixed up.

Finally, screw the valves at first finger-tight into the dosing head. While doing this, ensure that the seals or O-rings are correctly seated inside the valves and the dosing head.

	<b>WARNING</b>
<b>Caustic burns or other burns through dosing media!</b>	
If valves are serviced without replacing the seals, it can lead to leakage and to an eventual escape of the dosing media.	
⇒ Replace the seals when maintaining the valves.	

Required torque for tightening plastic valves into the dosing head:

MEMDOS LB	Torque (+/- 10%)
4 – 20	3 Nm
4-HP – 20-HP	3 Nm
35 – 60	5 Nm
80 – 260	15 Nm
310 - 400	15 Nm
510 - 1010	20 Nm

Table 12-3: Valve torque

For stainless steel valves with fibre seals or seals made of PTFE, the given torque values are the minimum values. Due to their elastic deformation, these must be re-tightened several times.

## 13 Troubleshooting

See below for information about how to rectify faults on the device or the system. If you cannot eliminate the fault, please consult with the manufacturer on further measures or return the dosing pump for repair.

### 13.1 Type of fault

#### 13.1.1 Dosing pump not delivering or output too low

Possible cause	Remedy
Wrong type of dosing pump selected	→ Check the dosing pump's technical data and if necessary select a type with a higher delivery capacity.
Valve leaking or blocked	→ Clean the valve and vent the dosing pump. → Tighten the screw connections.
Valve installed incorrectly	→ Reassemble the valve. Ensure that the valve balls are located above the valve seats.
Valve damaged (e.g. valve balls)	→ Remove the damaged parts or install a new valve.
Suction line is leaking	→ Seal the leak locations or replace the parts.
Suction line is blocked (e.g. screen in foot valve)	→ Clean the suction line
Shut-off valves closed	→ Open the shut-off valves Inspect the dosing pump for possible damage.
Suction head too high	→ Set the dosing pump to feed or reduce the suction head. → Install the pulsation dampener on the suction side. → Install a priming aid.
Viscosity too high	→ Possibly reduce the concentration of the dosing medium or increase the temperature. → Install spring-loaded valves. → Increase the pipe diameter.
Current supply interrupted	→ Reconnect the current supply

Table 13-1: Type of fault: Dosing pump not delivering or output too low

Possible cause	Remedy
The drive motor's electrical data does not match that of the mains supply	→ Check the electrical installation.
System back pressure too high (measured at discharge connection of dosing pump)	→ Clean blocked injection nozzle. → Install pulsation dampeners to reduce pressure peaks if pipes are too long. → Check function of safety valves.

Table 13-1: Type of fault: Dosing pump not delivering or output too low

#### 13.1.2 Dosing pump does not prime

Possible cause	Remedy
Valve leaking or blocked	→ Clean the valve and vent the dosing pump. → Tighten the screw connections.
Valve installed incorrectly	→ Reassemble the valve. Ensure that the valve balls are located above the valve seats.
Valve damaged (e.g. valve balls)	→ Remove the damaged parts or install a new valve.
Suction line is leaking	→ Seal the leak locations or replace the parts.
Suction line is blocked (e.g. screen in foot valve)	→ Clean the suction line
Shut-off valves closed	→ Open the shut-off valves Inspect the dosing pump for possible damage.
Suction head too high	→ Set the dosing pump to feed or reduce the suction head. → Install the pulsation dampener on the suction side. → Install a priming aid.
Viscosity too high	→ Possibly reduce the concentration of the dosing medium or increase the temperature. → Install spring-loaded valves. → Increase the pipe diameter.
Current supply interrupted	→ Reconnect the current supply

Table 13-2: Type of fault: Dosing pump does not prime

Possible cause	Remedy
Dry the valves	<ul style="list-style-type: none"> <li>➔ Dampen the dosing head and the valves</li> <li>➔ Vent the dosing head.</li> </ul>
Air in the suction line with simultaneous pressure on the discharge valve	<ul style="list-style-type: none"> <li>➔ Vent the dosing head or the lines.</li> </ul>

Table 13-2: Type of fault: Dosing pump does not prime

### 13.1.3 Delivery rate varies

Possible cause	Remedy
Valve leaking or blocked	<ul style="list-style-type: none"> <li>➔ Clean the valve and vent the dosing pump.</li> <li>➔ Tighten the screw connections.</li> </ul>
Valve damaged (e.g. valve balls)	<ul style="list-style-type: none"> <li>➔ Remove the damaged parts or install a new valve.</li> </ul>
Suction line is leaking	<ul style="list-style-type: none"> <li>➔ Seal the leak locations or replace the parts.</li> </ul>
Suction line is blocked (e.g. screen in foot valve)	<ul style="list-style-type: none"> <li>➔ Clean the suction line</li> </ul>
Viscosity too high	<ul style="list-style-type: none"> <li>➔ Possibly reduce the concentration of the dosing medium or increase the temperature.</li> <li>➔ Install spring-loaded valves.</li> <li>➔ Increase the pipe diameter.</li> </ul>
The drive motor's electrical data does not match that of the mains supply	<ul style="list-style-type: none"> <li>➔ Check the electrical installation.</li> </ul>
Suction side pressure too high (pump siphoning)	<ul style="list-style-type: none"> <li>➔ Install a back-pressure valve in the pressure line.</li> </ul>
Pressure peaks due to acceleration with long suction lines	<ul style="list-style-type: none"> <li>➔ Install a suction pressure regulator.</li> </ul>
Imprecise dosing due to changeable positive and negative suction heads	<ul style="list-style-type: none"> <li>➔ Install a suction pressure regulator.</li> </ul>
System back pressure too high (measured at discharge connection of dosing pump)	<ul style="list-style-type: none"> <li>➔ Clean blocked injection nozzle.</li> <li>➔ Install pulsation dampeners to reduce pressure peaks if pipes are too long.</li> <li>➔ Check function of safety valves.</li> </ul>

Table 13-3: Type of fault: Delivery rate varies

### 13.1.4 No stroke movement observed

Possible cause	Remedy
Dosing pump set to zero stroke	<ul style="list-style-type: none"> <li>➔ Set the stroke length adjusting knob correctly.</li> </ul>
Diaphragm return spring broken	<ul style="list-style-type: none"> <li>➔ Contact the manufacturer.</li> </ul>
Current supply interrupted	<ul style="list-style-type: none"> <li>➔ Reconnect the current supply</li> </ul>
The drive motor's electrical data does not match that of the mains supply	<ul style="list-style-type: none"> <li>➔ Check the electrical installation.</li> </ul>

Table 13-4: Type of fault: No stroke movement observed

### 13.1.5 Dosing pump delivery rate too high

Possible cause	Remedy
Suction side pressure too high (pump siphoning)	<ul style="list-style-type: none"> <li>➔ Install a back-pressure valve in the pressure line.</li> </ul>
Pressure peaks due to acceleration with long suction lines	<ul style="list-style-type: none"> <li>➔ Install a suction pressure regulator.</li> </ul>

Table 13-5: Type of fault: Dosing pump delivery rate too high

### 13.1.6 Diaphragm is torn or tears too often

Possible cause	Remedy
Shut-off valves closed	<ul style="list-style-type: none"> <li>➔ Open the shut-off valves Inspect the dosing pump for possible damage.</li> </ul>
Pressure peaks due to acceleration with long suction lines	<ul style="list-style-type: none"> <li>➔ Install a suction pressure regulator.</li> </ul>
The materials are not suitable for the dosing medium being used	<ul style="list-style-type: none"> <li>➔ Check the resistance of the materials.</li> </ul>
Diaphragm not screwed up to the end stop on the diaphragm rod	<ul style="list-style-type: none"> <li>➔ Screw a new diaphragm up to the end stop. On MEMDOS LB 4 – 60, the support plate must be clamped firmly between diaphragm and diaphragm rod.</li> </ul>
System back pressure too high (measured at discharge connection of dosing pump)	<ul style="list-style-type: none"> <li>➔ Clean blocked injection nozzle.</li> <li>➔ Install pulsation dampeners to reduce pressure peaks if pipes are too long.</li> <li>➔ Check function of safety valves.</li> </ul>
Media sediment in dosing head	<ul style="list-style-type: none"> <li>➔ Clean the dosing head.</li> </ul>

Table 13-6: Type of fault: Diaphragm is torn or tears too often

### 13.1.7 Loud noises on the dosing pump

Possible cause	Remedy
Roller bearing defective	→ Contact the manufacturer.

Table 13-7: Type of fault: Loud noises on the dosing pump

### 13.1.8 The drive is overloaded

Possible cause	Remedy
Shut-off valves closed	→ Open the shut-off valves Inspect the dosing pump for possible damage.
The drive motor's electrical data does not match that of the mains supply	→ Check the electrical installation.
Pressure peaks due to acceleration with long suction lines	→ Install a suction pressure regulator.
System back pressure too high (measured at discharge connection of dosing pump)	→ Clean blocked injection nozzle. → Install pulsation dampeners to reduce pressure peaks if pipes are too long. → Check function of safety valves.

Table 13-8: Type of fault: The drive is overloaded

### 13.1.9 Motor hums and does not start.

Possible cause	Remedy
The drive motor's electrical data does not match that of the mains supply	→ Check the electrical installation.
Capacitor defective, wrong size or connected incorrectly	→ Connect the capacitor correctly or replace.
System back pressure too high (measured at discharge connection of dosing pump)	→ Clean blocked injection nozzle. → Install pulsation dampeners to reduce pressure peaks if pipes are too long. → Check function of safety valves.
No or insufficient oil in the gearbox	→ Fill up the gearbox oil.

Table 13-9: Type of fault: Motor hums and does not start.

## 14 Spare parts

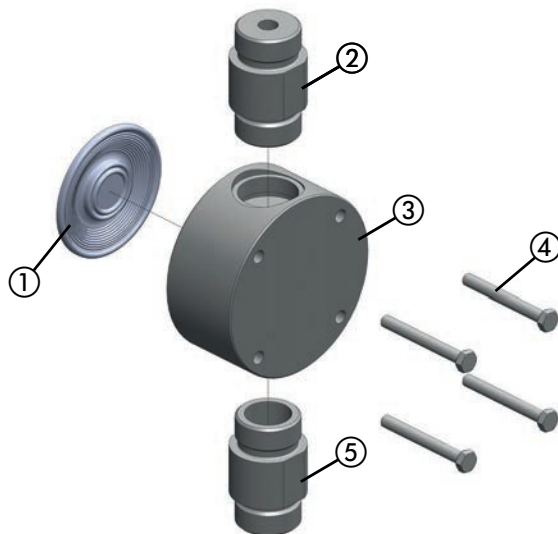

Fig. 14-1: Spare parts

Required kits for a complete service:

- 1 diaphragm spare parts kit,
- 1 dosing head spare parts kit.

### 14.1 Diaphragm spare parts kits

Diaphragm spare parts kit containing:

- 1 diaphragm ①,
- 1 set of dosing head screws ④.

Diaphragm kit	Type	Part No.
	LB 4, LB 10, LB 20	40356
	LB 35, LB 60	40357
	LB 80, LB 110, LB 150, LB 160	40358
	LB 210, LB 260	40359
	LB 310, LB 400	40360
	LB 510, LB 760, LB 1010	40361

Table 14-1: Diaphragm spare parts kits

### 14.2 Dosing head spare parts kits including valves

Dosing head spare parts kit containing:

- Dosing head ③,
- 1 set of dosing head screws ④.
- Pressure valve ②,
- Suction valve ⑤.

#### 14.2.1 Dosing head sets with double ball valves

Dosing head made of PVC	Type	Part No.
Glass/PVDF/FPM (ball/seat/seals)	LB 4, LB 10, LB 20	40385
	LB 4-HP, LB 10-HP, LB 20-HP	40547
Glass/PVDF/EPDM (ball/seat/seals)	LB 4, LB 10, LB 20	40399
	LB 4-HP, LB 10-HP, LB 20-HP	40551
Stainless steel (1.4571)/stainless steel (1.4571)/FPM (ball/seat/seals)	LB 4, LB 10, LB 20	40473
	LB 4-HP, LB 10-HP, LB 20-HP	40567
	LB 35, LB 60	40474
	LB 80, LB 110, LB 150, LB 160	40475
Stainless steel (1.4571)/stainless steel (1.4571)/EPDM (ball/seat/seals)	LB 4, LB 10, LB 20	40476
	LB 4-HP, LB 10-HP, LB 20-HP	40568
	LB 35, LB 60	40477
	LB 80, LB 110, LB 150, LB 160	40478
Glass/PVC/FPM (ball/seat/seals)	LB 35, LB 60	40386
	LB 80, LB 110, LB 150, LB 160	40387
Glass/PVC/EPDM (ball/seat/seals)	LB 35, LB 60	40400
	LB 80, LB 110, LB 150, LB 160	40401

Table 14-2: Spare parts kits dosing head made of PVC

Dosing head made of PP	Type	Part No.
Glass/PVDF/FPM (ball/seat/seals)	LB 4, LB 10, LB 20	40388
	LB 4-HP, LB 10-HP, LB 20-HP	40548
Glass/PVDF/EPDM (ball/seat/seals)	LB 4, LB 10, LB 20	40402
	LB 4-HP, LB 10-HP, LB 20-HP	40552
Glass/PP/FPM (ball/seat/seals)	LB 35, LB 60	40389
	LB 80, LB 110, LB 150, LB 160	40390
Glass/PP/EPDM (ball/seat/seals)	LB 35, LB 60	40403
	LB 80, LB 110, LB 150, LB 160	40404

Table 14-3: Spare parts kits dosing head made of PP

Dosing head made of PVDF	Type	Part No.
PTFE/PVDF/FPM (ball/seat/seals)	LB 4, LB 10, LB 20	40391
	LB 4-HP, LB 10-HP, LB 20-HP	40549
	LB 35, LB 60	40392
	LB 80, LB 110, LB 150, LB 160	40393
PTFE/PVDF/EPDM (ball/seat/seals)	LB 4, LB 10, LB 20	40405
	LB 4-HP, LB 10-HP, LB 20-HP	40553
	LB 35, LB 60	40406
	LB 80, LB 110, LB 150, LB 160	40407
PTFE/PVDF/PTFE (ball/seat/seals)	LB 4, LB 10, LB 20	40457
	LB 4-HP, LB 10-HP, LB 20-HP	40563
	LB 35, LB 60	40458
	LB 80, LB 110, LB 150, LB 160	40459

Table 14-4: Spare parts kits dosing head made of PVDF

Dosing head made of stainless steel (1.4571)	Type	Part No.
Stainless steel (1.4571)/stainless steel (1.4571)/FPM (ball/seat/seals)	LB 4, LB 10, LB 20	40394
	LB 4-HP, LB 10-HP, LB 20-HP	40550
	LB 35, LB 60	40395
	LB 80, LB 110, LB 150, LB 160	40396
Stainless steel (1.4571)/stainless steel (1.4571)/EPDM (ball/seat/seals)	LB 4, LB 10, LB 20	40408
	LB 4-HP, LB 10-HP, LB 20-HP	40554
	LB 35, LB 60	40409
	LB 80, LB 110, LB 150, LB 160	40410
Stainless steel (1.4571)/stainless steel (1.4571)/PTFE (ball/seat/seals)	LB 4, LB 10, LB 20	40465
	LB 4-HP, LB 10-HP, LB 20-HP	40565
	LB 35, LB 60	40466
	LB 80, LB 110, LB 150, LB 160	40467

Table 14-5: Spare parts kits dosing head made of stainless steel (1.4571)



Further sets in numerous material combinations can be found in Lutz-Jesco GmbH's actual price list.

### 14.2.2 Dosing head sets with spring-loaded valves

Dosing head made of PVC	Type	Part No.
Glass/PVDF/FPM/Hastelloy (ball/seat/seals/spring)	LB 4, LB 10, LB 20	40417
	LB 4-HP, LB 10-HP, LB 20-HP	40555
Glass/PVDF/EPDM/Hastelloy (ball/seat/seals/spring)	LB 4, LB 10, LB 20	40437
	LB 4-HP, LB 10-HP, LB 20-HP	40559
Stainless steel (1.4571)/stainless steel (1.4571)/FPM/Hastelloy (ball/seat/seals/spring)	LB 4, LB 10, LB 20	40479
	LB 4-HP, LB 10-HP, LB 20-HP	40569
	LB 35, LB 60	40480
	LB 80, LB 110, LB 150, LB 160	40481
	LB 210, LB 260	40482
	LB 310, LB 400	40545
	LB 510, LB 760, LB 1010	40483
Stainless steel/Stainless steel/EPDM/Hastelloy (ball/seat/seals/spring)	LB 4, LB 10, LB 20	40484
	LB 4-HP, LB 10-HP, LB 20-HP	40570
	LB 35, LB 60	40485
	LB 80, LB 110, LB 150, LB 160	40486
	LB 210, LB 260	40487
	LB 310, LB 400	40546
	LB 510, LB 760, LB 1010	40488
Glass/PVC/FPM/Hastelloy (ball/seat/seals/spring)	LB 35, LB 60	40418
	LB 80, LB 110, LB 150, LB 160	40419
Glass/PVC/EPDM/Hastelloy (ball/seat/seals/spring)	LB 35, LB 60	40438
	LB 80, LB 110, LB 150, LB 160	40439
PVDF/PVC/FPM/Hastelloy (ball/seat/seals/spring)	LB 210, LB 260	40420
	LB 310, LB 400	40535
	LB 510, LB 760, LB 1010	40421

Table 14-6: Spare parts kits dosing head made of PVC

Dosing head made of PVC	Type	Part No.
PVDF/PVC/EPDM/Hastelloy (ball/seat/seals/spring)	LB 210, LB 260	40440
	LB 310, LB 400	40539
	LB 510, LB 760, LB 1010	40441

Table 14-6: Spare parts kits dosing head made of PVC

Dosing head made of PP	Type	Part No.
Glass/PVDF/FPM/Hastelloy (ball/seat/seals/spring)	LB 4, LB 10, LB 20	40422
	LB 4-HP, LB 10-HP, LB 20-HP	40556
Glass/PVDF/EPDM/Hastelloy (ball/seat/seals/spring)	LB 4, LB 10, LB 20	40442
	LB 4-HP, LB 10-HP, LB 20-HP	40560
Glass/PP/FPM/Hastelloy (ball/seat/seals/spring)	LB 35, LB 60	40423
	LB 80, LB 110, LB 150, LB 160	40424
Glass/PP/EPDM/Hastelloy (ball/seat/seals/spring)	LB 35, LB 60	40443
	LB 80, LB 110, LB 150, LB 160	40444
PVDF/PP/FPM/Hastelloy (ball/seat/seals/spring)	LB 210, LB 260	40425
	LB 310, LB 400	40536
	LB 510, LB 760, LB 1010	40426
PVDF/PP/EPDM/Hastelloy (ball/seat/seals/spring)	LB 210, LB 260	40445
	LB 310, LB 400	40540
	LB 510, LB 760, LB 1010	40446

Table 14-7: Spare parts kits dosing head made of PP

Dosing head made of PVDF	Type	Part No.
PTFE/PVDF/FPM/Hastelloy (ball/seat/seals/spring)	LB 4, LB 10, LB 20	40427
	LB 4-HP, LB 10-HP, LB 20-HP	40557
	LB 35, LB 60	40428
	LB 80, LB 110, LB 150, LB 160	40429
PTFE/PVDF/EPDM/Hastelloy (ball/seat/seals/spring)	LB 4, LB 10, LB 20	40447
	LB 4-HP, LB 10-HP, LB 20-HP	40561
	LB 35, LB 60	40448
	LB 80, LB 110, LB 150, LB 160	40449
PTFE/PVDF/PTFE/Hastelloy (ball/seat/seals/spring)	LB 4, LB 10, LB 20	40460
	LB 4-HP, LB 10-HP, LB 20-HP	40564
	LB 35, LB 60	40461
	LB 80, LB 110, LB 150, LB 160	40462
PVDF/PVDF/FPM/Hastelloy (ball/seat/seals/spring)	LB 210, LB 260	40430
	LB 310, LB 400	40537
	LB 510, LB 760, LB 1010	40431
PVDF/PVDF/EPDM/Hastelloy (ball/seat/seals/spring)	LB 210, LB 260	40450
	LB 310, LB 400	40541
	LB 510, LB 760, LB 1010	40451
PVDF/PVDF/PTFE/Hastelloy (ball/seat/seals/spring)	LB 210, LB 260	40463
	LB 310, LB 400	40543
	LB 510, LB 760, LB 1010	40464

Table 14-8: Spare parts kits dosing head made of PVDF

Dosing head made of stainless steel (1.4571)	Type	Part No.
Stainless steel (1.4571)/stainless steel (1.4571)/FPM/Hastelloy (ball/seat/seals/spring)	LB 4, LB 10, LB 20	40432
	LB 4-HP, LB 10-HP, LB 20-HP	40558
	LB 35, LB 60	40433
	LB 80, LB 110, LB 150, LB 160	40434
	LB 210, LB 260	40435
	LB 310, LB 400	40538
	LB 510, LB 760, LB 1010	40436
Stainless steel (1.4571)/stainless steel (1.4571)/EPDM/Hastelloy (ball/seat/seals/spring)	LB 4, LB 10, LB 20	40452
	LB 4-HP, LB 10-HP, LB 20-HP	40562
	LB 35, LB 60	40453
	LB 80, LB 110, LB 150, LB 160	40454
	LB 210, LB 260	40455
	LB 310, LB 400	40542
	LB 510, LB 760, LB 1010	40456
Stainless steel (1.4571)/stainless steel (1.4571)/PTFE/Hastelloy (ball/seat/seals/spring)	LB 4, LB 10, LB 20	40468
	LB 4-HP, LB 10-HP, LB 20-HP	40566
	LB 35, LB 60	40469
	LB 80, LB 110, LB 150, LB 160	40470
	LB 210, LB 260	40471
	LB 310, LB 400	40544
	LB 510, LB 760, LB 1010	40472

Table 14-9: Spare parts kits dosing head made of stainless steel (1.4571)



Further sets in numerous material combinations can be found in Lutz-Jesco GmbH's actual price list.

## 15 Delivery characteristic curves

This Chapter is intended to give you an idea of the delivery capacity that the dosing pump can achieve at specific back pressures. These delivery capacities were determined on the manufacturer's test stands. They apply at 20 °C (68 °F) for water, at 100 % stroke frequency. The delivery capacity depends on the medium (density and viscosity) and temperature. Since these conditions differ at every location of usage, the delivery capacity of the dosing pump should be measured by gauging it at the operating company's installation.

At 60 Hz operation, values are increased by a factor of 1.2.

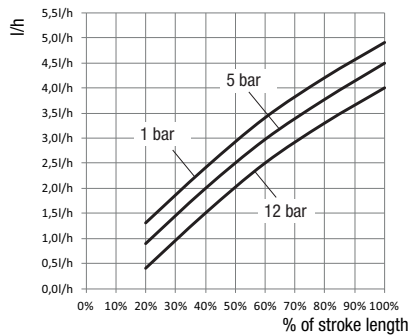

MEMDOS LB 4

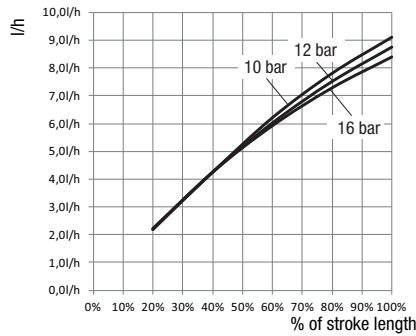

MEMDOS LB 4-HP

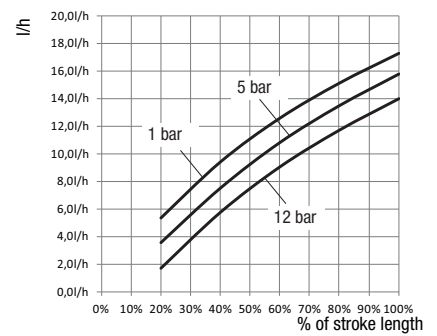

MEMDOS LB 10

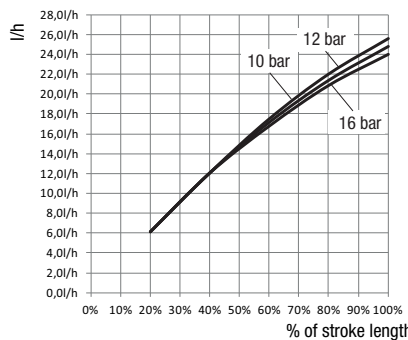

MEMDOS LB 10-HP

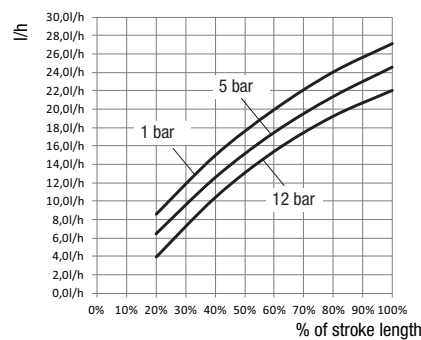

MEMDOS LB 20

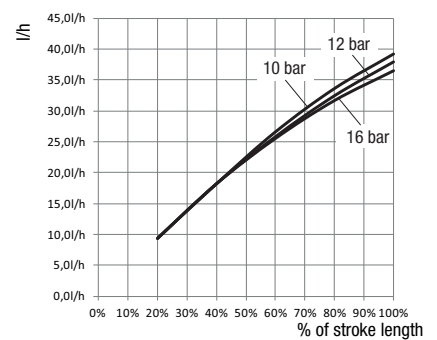

MEMDOS LB 20-HP

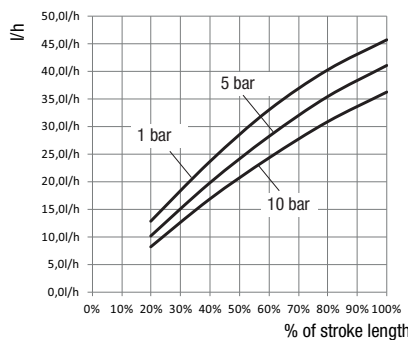

MEMDOS LB 35

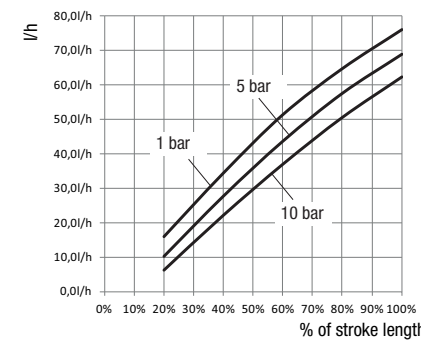

MEMDOS LB 60

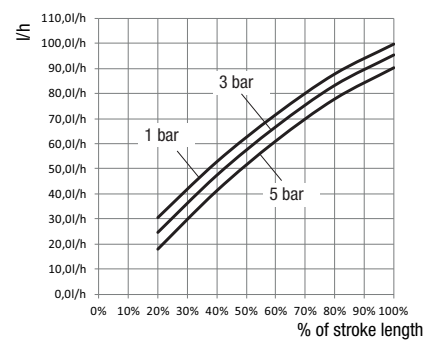

MEMDOS LB 80

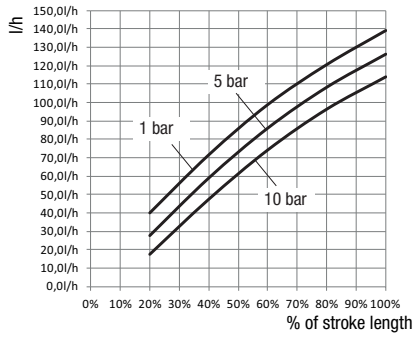

MEMDOS LB 110

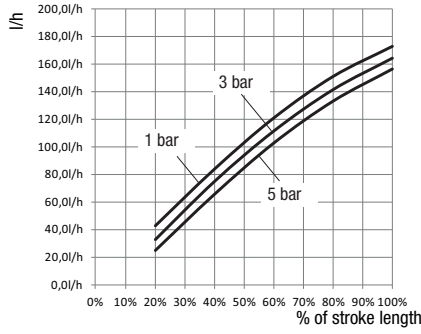

MEMDOS LB 150

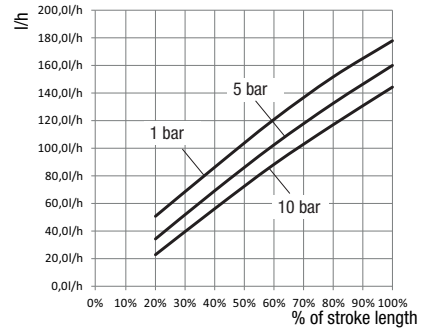

MEMDOS LB 160

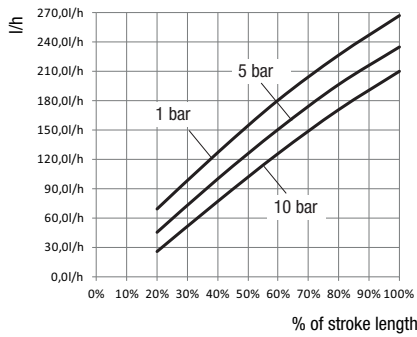

MEMDOS LB 210

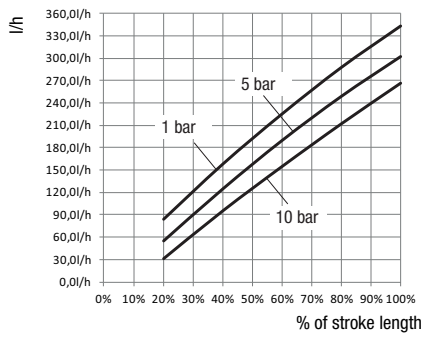

MEMDOS LB 260

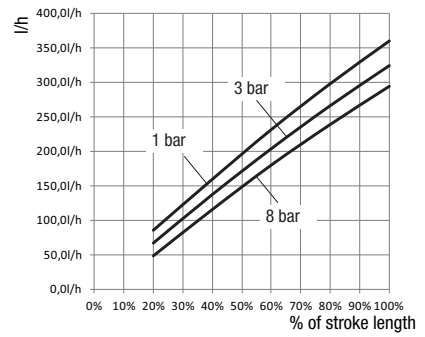

MEMDOS LB 310

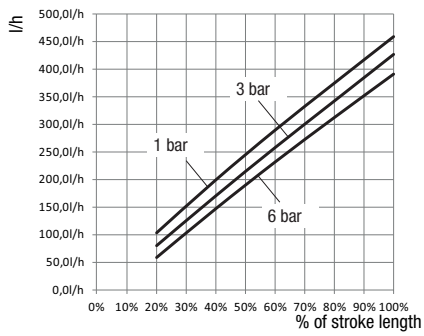

MEMDOS LB 400

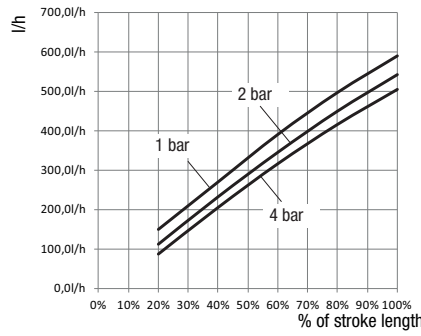

MEMDOS LB 510

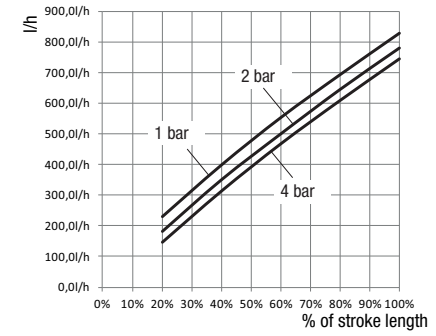

MEMDOS LB 760

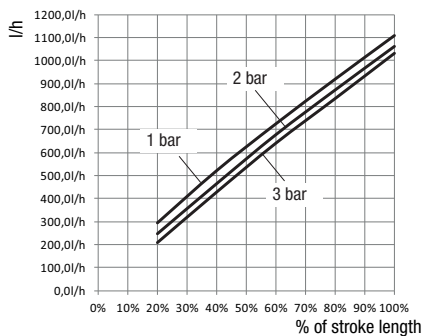

MEMDOS LB 1010

## 16 EC Declaration of Conformity



**(DE) EG-Konformitätserklärung**

Hiermit erklären wir, dass das nachfolgend bezeichnete Gerät aufgrund seiner Konzipierung und Bauart sowie in der von uns in Verkehr gebrachten Ausführung den einschlägigen grundlegenden Sicherheits- und Gesundheitsanforderungen der aufgeführten EG-Richtlinien entspricht. Bei einer nicht mit uns abgestimmten Änderung am Gerät verliert diese Erklärung ihre Gültigkeit.

**(EN) EC Declaration of Conformity**

We hereby certify that the device described in the following complies with the relevant fundamental safety and sanitary requirements and the listed EC regulations due to the concept and design of the version sold by us.

If the device is modified without our consent, this declaration loses its validity.

**(FR) Déclaration de conformité CE**

Nous déclarons sous notre propre responsabilité que le produit ci-dessous mentionné répond aux exigences essentielles de sécurité et de santé des directives CE énumérées aussi bien sur le plan de sa conception et de son type de construction que du modèle que nous avons mis en circulation.

Cette déclaration perdra sa validité en cas d'une modification effectuée sur le produit sans notre accord explicite.

**(ES) Declaración de conformidad CE**

Por la presente declaramos que, dados la concepción y los aspectos constructivos del modelo puesto por nosotros en circulación, el aparato mencionado a continuación cumple con los requisitos sanitarios y de seguridad vigentes de las directivas de la U.E. citadas a continuación.

Esta declaración será invalidada por cambios en el aparato realizados sin nuestro consentimiento.

**(NL) EU-overeenstemmingsverklaring**

Ondergetekende Lutz-Jesco GmbH, bevestigt, dat het volgende genoemde apparaat in de door ons in de handel gebrachte uitvoering voldoet aan de eis van, en in overeenstemming is met de EU-richtlijnen, de EU-veiligheidsstandaard en de voor het product specifieke standaard. Bij een niet met ons afgestemde verandering aan het apparaat verliest deze verklaring haar geldigheid.

**(PT) Declaração de conformidade CE**

Declaramos pelo presente documento que o equipamento a seguir descrito, devido à sua concepção e ao tipo de construção daí resultante, bem como a versão por nós lançada no mercado, cumpre as exigências básicas aplicáveis de segurança e de saúde das directivas CE indicadas.

A presente declaração perde a sua validade em caso de alteração ao equipamento não autorizada por nós.

**Bezeichnung des Gerätes:**

Motor-Membrandosierpumpe

**Description of the unit:**

Motor-driven diaphragm dosing pump

**Désignation du matériel:**

Pompe doseuse à membrane entraînée par moteur

**Descripción de la mercancía:**

Bomba dosificadora de membrana accionada por motor

**Omschrijving van het apparaat:**

Motor-Membraandoseerpompen

**Designação do aparelho:**

Bomba doseadora de membrana a motor

**Typ:**

MEMDOS LB 4 – 1010, MEMDOS LB 4-HP – 20-HP

**Type:**

**EG-Richtlinien:**

2006/42/EG

**EC directives:**

Die Schutzziele der Niederspannungsrichtlinie 2006/95/EG wurden gemäß Anhang I, Nr. 1.5.1 der Maschinenrichtlinie 2006/42/EG eingehalten.

The protective aims of the Low Voltage Directive 2006/95/EC were adhered to in accordance with Annex I, No. 1.5.1 of the Machinery Directive 2006/42/EC.

**Harmonisierte Normen:**

EN ISO 12100, EN 809

**Harmonized standards:**

**Dokumentationsbevollmächtigter:**

Lutz-Jesco GmbH

**Authorized person for documentation:**

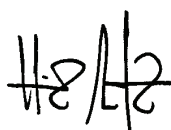

Heinz Lutz  
Geschäftsführer / Chief Executive Officer  
Lutz-Jesco GmbH  
Wedemark, 01.12.2013

Lutz-Jesco GmbH  
Am Bostelberge 19  
30900 Wedemark  
Germany



**(DE) EG-Konformitätserklärung**

Hiermit erklären wir, dass das nachfolgend bezeichnete Gerät aufgrund seiner Konzipierung und Bauart sowie in der von uns in Verkehr gebrachten Ausführung den einschlägigen grundlegenden Sicherheits- und Gesundheitsanforderungen der aufgeführten EG-Richtlinien entspricht. Bei einer nicht mit uns abgestimmten Änderung am Gerät verliert diese Erklärung ihre Gültigkeit.

**(EN) EC Declaration of Conformity**

We hereby certify that the device described in the following complies with the relevant fundamental safety and sanitary requirements and the listed EC regulations due to the concept and design of the version sold by us.

If the device is modified without our consent, this declaration loses its validity.

**(FR) Déclaration de conformité CE**

Nous déclarons sous notre propre responsabilité que le produit ci-dessous mentionné répond aux exigences essentielles de sécurité et de santé des directives CE énumérées aussi bien sur le plan de sa conception et de son type de construction que du modèle que nous avons mis en circulation.

Cette déclaration perdra sa validité en cas d'une modification effectuée sur le produit sans notre accord explicite.

**(ES) Declaración de conformidad CE**

Por la presente declaramos que, dados la concepción y los aspectos constructivos del modelo puesto por nosotros en circulación, el aparato mencionado a continuación cumple con los requisitos sanitarios y de seguridad vigentes de las directivas de la U.E. citadas a continuación.

Esta declaración será invalidada por cambios en el aparato realizados sin nuestro consentimiento.

**Bezeichnung des Gerätes:**

Motor-Membrandosierpumpe

**Description of the unit:**

Motor-driven diaphragm dosing pump

**Désignation du matériel:**

Pompe doseuse à membrane entraînée par moteur

**Descripción de la mercancía:**

Bomba dosificadora de membrana accionada por motor

**Typ:**

MEMDOS LB Ex 4 – 1010, MEMDOS LB 4-HP Ex – 20-HP Ex

**Type:**

**Registriernummer:**

PTB 12 ATEX D036

**Registration number:**

**Ex-Kennzeichnung:**

**Ex label:**

**Dosierpumpe ohne Motor / Dosing pump without motor:**

Ⓢ II 2G Ex ck IIC T4

**Dosierpumpe mit Motor für Betrieb in Zone 1 / Dosing pump with motor for operation in zone 1:**

Ⓢ II 2G Ex de IIC T4

**Dosierpumpe mit Motor für Betrieb in Zone 2 / Dosing pump with motor for operation in zone 2:**

Ⓢ II 2G Ex e IIC T3

Das Gesamtsystem hat in Summe keinen höheren Schutzgrad als die verwendeten Motoren für sich. Der zulässige Einsatzbereich definiert sich somit über den Schutzgrad der Motoren. Dieser wird am Typenschild des Motors vom Hersteller separat ausgewiesen.

In total, the complete system does not have a higher protection class than the motors used in it. The permissible scope of application is therefore defined by the protection class of the motors. This is specified separately by the manufacturer on the rating plate on the motor.

**EG-Richtlinien:**

**EC directives:**

2006/42/EG, 94/9/EG

Die Schutzziele der Niederspannungsrichtlinie 2006/95/EG wurden gemäß Anhang I, Nr. 1.5.1 der Maschinenrichtlinie 2006/42/EG eingehalten.

The protective aims of the Low Voltage Directive 2006/95/EC were adhered to in accordance with Annex I, No. 1.5.1 of the Machinery Directive 2006/42/EC.

**Harmonisierte Normen:**

**Harmonized standards:**

EN ISO 12100, EN 809, EN 13463-1, EN 13463-5, EN 13463-8

**Dokumentationsbevollmächtigter:**

**Authorized person for documentation:**

Lutz-Jesco GmbH

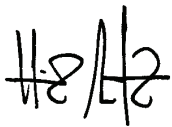

Heinz Lutz  
Geschäftsführer / Chief Executive Officer  
Lutz-Jesco GmbH  
Wedemark, 01.12.2013

Lutz-Jesco GmbH  
Am Bostelberge 19  
30900 Wedemark  
Germany

## 17 Declaration of harmlessness

Please copy the declaration, stick it to the outside of the packaging and return it with the device.

### Declaration of no objection

Please fill out a separate form for each appliance!

We forward the following device for repairs:

Device and device type: ..... Part-no.: .....

Order No.: ..... Date of delivery: .....

Reason for repair: .....  
.....  
.....

#### Dosing medium

Description: ..... Irritating:  Yes  No

Properties: ..... Corrosive:  Yes  No

We hereby certify, that the product has been cleaned thoroughly inside and outside before returning, that it is free from hazardous material (i.e. chemical, biological, toxic, flammable, and radioactive material) and that the lubricant has been drained.

If the manufacturer finds it necessary to carry out further cleaning work, we accept the charge will be made to us.

We assure that the aforementioned information is correct and complete and that the unit is dispatched according to the legal requirements.

Company / address: ..... Phone: .....

..... Fax: .....

..... Email: .....

Customer No.: ..... Contact person: .....

Date, Signature: .....

## Notes

## 18 Warranty application

### Warranty Application

Please copy and send it back with the unit!

If the device breaks down within the period of warranty, please return it in a cleaned condition with the complete warranty application, filled out.

#### Sender

Company: ..... Phone: ..... Date: .....

Address: .....

Contact person: .....

Manufacturer order no.: ..... Date of delivery:.....

Device type: ..... Serial number: .....

Nominal capacity / nominal pressure: .....

Description of fault:.....

.....

.....

.....

.....

.....

.....

.....

.....

#### Service conditions of the device

Point of use / system designation:.....

.....

.....

Accessories used (suction line etc.):.....

.....

.....

.....

.....

Commissioning (date): .....

Duty period (approx. operating hours): .....

Please describe the specific installation and enclose a simple drawing or picture of the chemical feed system, showing materials of construction, diameters, lengths and heights of suction and discharge lines.

## Notes

## 19 Index

### A

AC motors	
electrical connection .....	33
technical data .....	16
Accessories .....	26

### B

Back-pressure valve .....	28
---------------------------	----

### C

Change the oil .....	39
Commissioning .....	36
Connecting a leakage drain .....	25
Control .....	34

### D

Declaration of harmlessness .....	53
Delivery capacity data .....	13
Delivery characteristic curves .....	49
Device revision .....	8
Diaphragm	
Spare parts kits .....	45
Diaphragm replacement .....	40
Dimensioned drawings .....	20
Dimensions .....	20
Disposal of old units .....	37
Dosing head	
spare parts kits .....	45
Dosing media	
Permitted media temperatures .....	14
Prohibited dosing media .....	8

### E

EC Declaration of Conformity .....	51
Electric servomotor	
Commissioning .....	37
Connection .....	33
Dimensions .....	22
Technical specifications .....	19
Electrical data	
motor data .....	16
Electrical installation .....	32
Ex label .....	9
Explosion risk areas	
Ex labelling of the dosing pump .....	9
ratings plate with ATEX label .....	12
Three-phase motors in explosion protection versions .....	17
use in explosion risk areas .....	8
Explosive risk areas	
warnings .....	6, 32, 38

### F

Foreseeable misuse .....	9
Function description .....	12

### H

Hazards due to non-compliance with the safety instructions .....	6
Hydraulic accessories .....	26
Hydraulic installations .....	24

### I

Injection nozzle .....	26
Installation .....	23
Installing the Dosing Pump .....	23
Instructions for action	
identification .....	4
Intended purpose .....	8

### M

Maintenance .....	38
Maintenance intervals .....	39
Maintenance kits .....	45
Motor data .....	16

### N

Notes to the Reader .....	4
---------------------------	---

### O

Operating conditions and limits .....	14
Operation .....	35

### P

Personal protective equipment .....	6
Personnel qualification .....	6
Pressure relief valve .....	27
Priming aid .....	30
Product description .....	11
Product warranty .....	8
Protective equipment	
Personal protective equipment .....	6
Pulsation dampener .....	29

### R

Ratings plate .....	12
Rotational direction of the motor .....	33

### S

Safety .....	5
--------------	---

Scope of delivery .....11  
 Set up information .....23  
 Shutdown .....37  
 Shutting down in an emergency .....37  
 Signal words  
   Explanation .....4  
 Spare parts .....45  
 Specialist staff .....7  
 Storage .....37  
 Stroke length adjustment ..... 12, 34  
 Structure of the dosing pump .....11  
 Suction pressure regulator ..... 28, 31  
 Suspensions .....30  
 System piping .....25

**T**

Technical specifications .....13  
 Temperatures  
   Permitted ambient temperature .....14  
   Permitted medium temperatures .....14  
 Three-phase  
   explosion protection versions .....17  
 Three-phase motors  
   electrical connection .....32  
   technical data .....16  
 Tighten up dosing head bolts .....40  
 Trained electricians .....7  
 Trained electricians with additional qualification for explosion  
   protection .....7  
 Trained persons .....7  
 Transportation .....37  
 Troubleshooting .....42

**U**

Use in explosion risk areas .....8

**V**

Valve  
   alignment .....25  
   maintenance .....41

**W**

Wall console .....23  
 Warning signs  
   Explanation .....4  
 Warnings  
   explosive risk areas ..... 6, 32, 38  
   General warnings .....5  
   identification .....4  
 Warranty application .....55  
 Working in a safety-conscious manner .....6



### Product Range

**Lutz Pumpen GmbH**  
P.O. Box 1462 • D-97864 Wertheim  
[www.lutz-pumpen.de](http://www.lutz-pumpen.de)



Barrel and Container Pumps



Flow Meters



Double Diaphragm Pumps



Centrifugal Pumps

### Product Range

**Lutz-Jesco GmbH**  
P.O. Box 100164 • D-30891 Wedemark  
[www.lutz-jesco.com](http://www.lutz-jesco.com)



Dosing Pumps



Chlorinators



Chemical Centrifugal Pumps



### TECHNOPOL®

Products for the disinfection of swimming pool water based on salt water electrolysis and domestic water technology



Measuring and Control Equipment



Disinfection



Standard Plus



The Lutz-Jesco App for iPads is available from the iTunes App Store.  
Additional information can be found at [www.lutz-jesco.com](http://www.lutz-jesco.com)



Headquarters  
**Lutz-Jesco GmbH**  
Am Bostelberge 19  
30900 Wedemark  
Germany

Tel.: +49 5130 5802-0  
Fax: +49 5130 580268

E-mail: [info@lutz-jesco.com](mailto:info@lutz-jesco.com)  
Website: [www.lutz-jesco.de](http://www.lutz-jesco.de)

Hungary  
**Lutz-Jesco Üzletág**  
Vasvári P. u. 9.  
9024 Győr  
Hungary

Tel.: +36 96 523046  
Fax: +36 96 523047

E-mail: [info@lutz-jesco.hu](mailto:info@lutz-jesco.hu)  
Website: [www.lutz-jesco.hu](http://www.lutz-jesco.hu)

Austria  
**Lutz-Jesco GmbH**  
Aredstraße 7/2  
2544 Leobersdorf  
Austria

Tel.: +43 2256 62180  
Fax: +43 2256 6218062

E-mail: [info@lutz-jesco.at](mailto:info@lutz-jesco.at)  
Website: [www.lutz-jesco.at](http://www.lutz-jesco.at)

Netherlands  
**Lutz-Jesco Nederland B.V.**  
Nijverheidstraat 14 C  
2984 AH Ridderkerk  
Netherlands

Tel.: +31 180 499460  
Fax: +31 180 497516

E-mail: [info@lutz-jesco.nl](mailto:info@lutz-jesco.nl)  
Website: [www.lutz-jesco.nl](http://www.lutz-jesco.nl)



Great Britain  
**Lutz-Jesco (GB) Ltd.**  
Gateway Estate  
West Midlands Freeport  
Birmingham B26 3QD  
Great Britain

Tel.: +44 121 782 2662  
Fax: +44 121 782 2680

E-mail: [info@lutz-jesco.co.uk](mailto:info@lutz-jesco.co.uk)  
Website: [www.lutz-jesco.co.uk](http://www.lutz-jesco.co.uk)

USA  
**Lutz-JESCO America Corp.**  
55 Bermar Park  
Rochester, N.Y. 14624  
USA

Tel.: +1 585 426-0990  
Fax: +1 585 426-4025

E-mail: [mail@jescoamerica.com](mailto:mail@jescoamerica.com)  
Website: [www.lutzjescoamerica.com](http://www.lutzjescoamerica.com)

East Asia  
**Lutz-Jesco East Asia Sdn Bhd**  
6 Jalan Saudagar U1/16  
Hicom Glenmarie Industrial Park  
40150 Shah Alam/ Selangor  
Malaysia

Tel.: +603 55692322  
Fax: +603 55691322

E-mail: [info@lutz-jescoasia.com](mailto:info@lutz-jescoasia.com)  
Website: [www.lutz-jescoasia.com](http://www.lutz-jescoasia.com)

Middle East  
**Lutz-Jesco Middle East FZE**  
P.O. Box 9614  
SAIF-Free Zone Center  
Sharjah  
UAE

Tel.: +971 6 5572205  
Fax: +971 6 5572230

E-mail: [info@jescome.com](mailto:info@jescome.com)  
Website: [www.jescome.com](http://www.jescome.com)

