

Piston diaphragm dosing pump

MEMDOS KMS LB/LA

Operating instructions

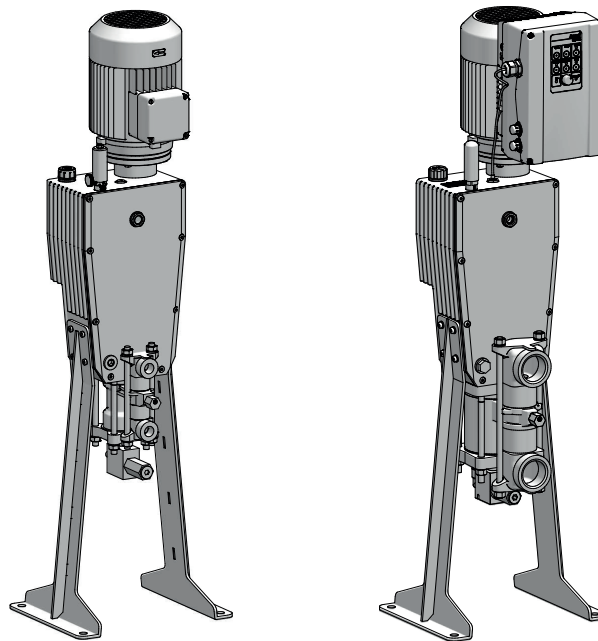

Read the operating manual!

The user is responsible for installation and operation related mistakes!

Table of Contents

1	Notes for the Reader	4	10.4	Operating panel MEMDOS KMS LA	26
1.1	General non-discrimination	4	10.5	General.....	26
1.2	Explanation of the signal words	4	10.6	Operating modes	26
1.3	Explanation of the warning signs	4	10.7	Extended functions	27
1.4	Identification of warnings	4	10.8	The status of the pump.....	27
1.5	Identification of action instructions	4	10.9	Error messages	28
2	Safety	5	11	Operation	30
2.1	General warnings.....	5	11.1	Commissioning the dosing pump.....	30
2.2	Warnings for use within explosive-risk zones	5	11.2	Adjusting the delivery rate.....	31
2.3	Hazards due to non-compliance with the safety instructions	6	11.3	Decommissioning the dosing pump.....	31
2.4	Working in a safety-conscious manner	6	11.4	Shutting down in an emergency	32
2.5	Personal protective equipment	6	11.5	Storage	32
2.6	Personnel qualification	6	11.6	Transportation.....	32
3	Intended use	8	11.7	Disposal of old equipment.....	32
3.1	Notes on product warranty	8	12	Maintenance	33
3.2	Intended purpose	8	12.1	Maintenance intervals.....	33
3.3	Principles	8	12.2	Change the oil.....	34
3.4	Prohibited dosing media.....	8	12.3	Tightening the dosing head nuts.....	34
3.5	Foreseeable misuse	8	12.4	Diaphragm replacement	35
4	Product description	10	12.5	Changing the ball valves.....	36
4.1	Properties.....	10	12.6	Changing the poppet valves	36
4.2	Scope of delivery	10	13	Troubleshooting	37
4.3	Structure MEMDOS KMS LB/LA.....	10	13.1	Type of fault	37
4.4	Control elements MEMDOS KMS LA.....	11	14	Spare parts	39
4.5	Function description MEMDOS KMS LB/LA.....	11	15	Delivery characteristic curves	40
4.6	Rating plate	12	16	EU Declaration of Conformity	42
5	Technical data	13	17	Declaration of no objection	43
5.1	Delivery capacity data	13	18	Warranty claim	44
5.2	Operating conditions and limits	13	19	Index	45
5.3	Other data	14			
5.4	Motor data.....	14			
5.5	AC drive 120 V or 230 V	16			
6	Dimensions	17			
6.1	MEMDOS KMS LB/LA	17			
7	Installing the Dosing Pump	18			
7.1	Set up information	18			
7.2	Installation on a wall console.....	18			
8	Hydraulic installations	19			
8.1	Design of the system.....	19			
8.2	General installation	20			
8.3	System piping.....	20			
8.4	Suction and pressure valves.....	20			
8.5	Hydraulic accessories	20			
9	Electrical installation	22			
9.1	Drive motor connection	22			
9.2	Description of connection sockets MEMDOS KMS LA	23			
10	Control	25			
10.1	Stroke length adjustment	25			
10.2	Vent the dosing head.....	25			
10.3	Controllable safety valve of the dosing head.....	25			

1 Notes for the Reader

This operating manual contains information and behaviour rules to ensure safe and intended operation of the dosing pump MEMDOS KMS LB/LA.

Observe the following principles:

- Read the entire operating manual prior to starting-up the device.
- Ensure that everyone who works with or on the dosing pump has read the operating instructions and follows them.
- Keep the operating instructions for the entire service life of the dosing pump.
- Pass on the operating instructions to any subsequent owner of the dosing pump.

1.1 General non-discrimination

In this operating manual, only the male gender is used where grammar allows gender allocation. The purpose of this is to make the text easy to read. Men and women are always referred to equally. We would like to ask female readers for understanding of this text simplification.

1.2 Explanation of the signal words







Different signal words in combination with warning signs are used in this operating manual. Signal words illustrate the gravity of possible injuries if the risk is ignored:

Signal word	Meaning
DANGER!	Refers to imminent danger. Ignoring this sign may lead to death or the most serious injuries.
WARNING	Refers to a potentially hazardous situation. Failure to follow this instruction may lead to death or severe injuries.
CAUTION!	Refers to a potentially hazardous situation. Failure to follow this instruction may lead to minor injury or damage to property.
PLEASE NOTE	Refers to a danger which, if ignored, may lead to risk to the machine and its function.

Tab. 1: Explanation of the signal words

1.3 Explanation of the warning signs

Warning signs represent the type and source of a danger:

Warning sign	Type of danger
	General danger zone
	Danger of electric shock
	Danger of caustic or other burns
	Danger of explosions
	Danger of electromagnetic radiation
	Danger of automatic start up
	Danger of damage to machine or functional influences

Tab. 2: Explanation of the warning signs

1.4 Identification of warnings

Warnings are intended to help you recognise risks and avoid negative consequences.

This is how warnings are identified:

Warning sign	SIGNAL WORD
Description of danger.	
Consequences if ignored.	
⇒ The arrow signals a safety precaution to be taken to eliminate the danger.	

1.5 Identification of action instructions

This is how pre-conditions for action are identified:

- ✓ Pre-condition for action which must be met before taking action.
- ✘ A resource such as a tool or auxiliary materials required to perform the operating instructions.

This is how instructions for action are identified:

- ➔ Separate step with no follow-up action.
- 1. First step in a series of steps.
- 2. Second step in a series of steps.
 - ▶ Result of the above action.
- ✓ **Action completed, aim achieved.**

2 Safety

2.1 General warnings

The following warnings are intended to help you to eliminate the dangers that can arise while handling the dosing pump. Risk prevention measures always apply regardless of any specific action.

Safety instructions warning against risks arising from specific activities or situations can be found in the respective sub-chapters.

	DANGER!
<p>Mortal danger from electric shock!</p> <p>Wrongly connected or located cables or damaged ones can injure you.</p> <ul style="list-style-type: none"> ⇒ Only connect the device to an earthed power supply. ⇒ Replace damaged cables without delay. ⇒ Do not use extension cables. ⇒ Do not bury cables. ⇒ Secure cables to avoid being damaged by other equipment. 	

	WARNING
<p>Danger from unsuitable materials</p> <p>The materials of the dosing pump and hydraulic parts of the system must be suitable for the dosing medium that is used. Should this not be the case, the dosing media may leak.</p> <ul style="list-style-type: none"> ⇒ Make sure that the materials you are using are suitable for the dosing medium. ⇒ Make sure that the lubricants, adhesives, sealants, etc. that you use are suitable for the dosing medium. 	

	WARNING
<p>Danger of automatic start up!</p> <p>After connecting the mains supply, residual dosing media in the dosing head can spray out.</p> <ul style="list-style-type: none"> ⇒ Before connecting the mains supply, connect the dosing lines. ⇒ Check that all the screw connections have been tightened correctly and are leak-proof. 	

	WARNING
<p>Caustic burns or other burns through dosing media!</p> <p>While working on the dosing head, valves and connections, you may come into contact with dosing media.</p> <ul style="list-style-type: none"> ⇒ Use sufficient personal protective equipment. ⇒ Rinse the dosing pump with a liquid (e. g. water) which does not pose any risk. Ensure that the liquid is compatible with the dosing medium. ⇒ Release pressure in hydraulic parts. ⇒ Never look into open ends of plugged pipelines and valves. 	

	CAUTION!
<p>Danger when changing the dosing medium!</p> <p>Changing the dosing media can provoke unexpected reactions, damage to property and injury.</p> <ul style="list-style-type: none"> ⇒ Clean the dosing pump and the system parts in contact with the media thoroughly before changing the dosing medium. 	

	CAUTION!
<p>Increased risk of accidents due to insufficient qualification of personnel!</p> <p>Dosing pumps and their accessories may only be installed, operated and maintained by personnel with sufficient qualifications. Insufficient qualification will increase the risk of accidents.</p> <ul style="list-style-type: none"> ⇒ Ensure that all action is taken only by personnel with sufficient and corresponding qualifications. ⇒ Prevent access to the system for unauthorised persons. 	

2.2 Warnings for use within explosive-risk zones

ATEX certified versions of the dosing pump can be used in explosive risk areas. The following warnings only apply for use in such areas:

	DANGER!
<p>Danger to life through explosions!</p> <p>Explosions may result which could result in fatal injuries.</p> <ul style="list-style-type: none"> ⇒ Use only ATEX certified versions of the dosing pump in explosive risk areas (check the information on the ratings plate for this). 	

	DANGER!
Danger to life from electrostatic charge!	
<p>Static electricity in explosive risk areas can build up when dosing flammable liquids. Explosions may result which could result in fatal injuries.</p> <p>⇒ Earth the dosing pump, drive motor and all metal parts along the suction and pressure piping route.</p> <p>⇒ Only use dosing heads made of stainless steel. In exceptional cases, carbon-filled PTFE dosing heads are also possible. For this, contact Lutz-Jesco GmbH.</p>	

2.3 Hazards due to non-compliance with the safety instructions

Failure to follow the safety instructions may endanger not only persons, but also the environment and the device.

The specific consequences can be:

- failure of vital functions of the dosing pump and the system,
- Failure of required maintenance and repair methods,
- Danger for individuals through dangerous dosing media,
- danger to the environment caused by substances leaking from the system.

2.4 Working in a safety-conscious manner

Besides the safety instructions specified in this operating manual, further safety rules apply and must be followed:

- accident prevention regulations
- Safety and operating provisions
- safety provisions for handling dangerous substances (mostly the safety data sheets to dosing media),
- Environmental protection provisions,
- applicable standards and legislation.



2.5 Personal protective equipment

Based on the degree of risk posed by the dosing medium and the type of work you are carrying out, you must use corresponding protective equipment. Read the Accident Prevention Regulations and the Safety Data Sheets to the dosing media find out what protective equipment you need.

You will require the minimum of the following personal protective equipment:

Personal protective equipment required	
	Protective goggles

Tab. 3: Personal protective equipment required

Personal protective equipment required	
	Protective clothing
	Protective gloves

Tab. 3: Personal protective equipment required

Wear the following personal protective equipment when performing the following tasks:

- Commissioning,
- working on the dosing pump while running,
- Shut-down,
- Maintenance work,
- Disposal.

2.6 Personnel qualification

Any personnel who work on the dosing pump must have appropriate special knowledge and skills.

Anybody who works on the dosing pump must meet the conditions below:

- Attendance at all the training courses offered by the owner,
- Personal suitability for the respective activity,
- sufficient qualification for the respective activity,
- Training in handling of the dosing pump,
- knowledge of safety equipment and the way this equipment functions,
- knowledge of this operating manual, particularly of safety instructions and sections relevant for the activity,
- Knowledge of fundamental regulations regarding health and safety and accident prevention.

All persons must generally have the following minimum qualification:

- Training as specialists to carry out work on the dosing pump unsupervised,
- Sufficient training that they can work on the dosing pump under the supervision and guidance of a trained specialist.

These operating instructions differentiate between these user groups:

2.6.1 Specialist staff

Thanks to their professional training, knowledge, experience and knowledge of the relevant specifications, specialist staff are able to perform the job allocated to them and recognise and/or eliminate any possible dangers by themselves.

2.6.2 Trained electricians

Due to their professional training, knowledge and experience as well as knowledge of specific standards and provisions, trained electricians are able to do the electrical work assigned to them and to recognise and avoid any potential dangers by themselves.

They are specially trained for their specific working environment and are familiar with relevant standards and provisions.

They must comply with the legally binding regulations on accident prevention.

2.6.3 Trained electricians with additional qualification for explosion protection

Trained electricians with additional qualification for explosion protection fulfil the criteria to act as a competent person to meet all the special requirements needed when working in explosive risk areas.

They are specially trained for their work environment in explosive risk areas and know all the relevant standards and regulations.

Above all, they have the required specialist knowledge about explosion protection like, for example, ignition protection classes, flash points, density ratios, zoning, device categories, temperature classes etc.

2.6.4 Trained persons

Trained persons have received training from the operator about the tasks they are to perform and about the dangers stemming from improper behaviour.

In the table below you can check what qualifications are the pre-condition for the respective tasks. Only people with appropriate qualifications are allowed to perform these tasks!

Qualification	Activities
Specialist staff	<ul style="list-style-type: none"> ■ Assembly ■ Hydraulic installations ■ Maintenance ■ Repairs ■ Commissioning ■ Taking out of operation ■ Disposal ■ Fault rectification
Trained electricians	<ul style="list-style-type: none"> ■ Electrical installation ■ Installing the electric servomotor ■ Rectifying electrical faults
Trained electricians with additional qualification for explosion protection	<ul style="list-style-type: none"> ■ Electrical installation in explosive risk areas ■ Fault rectification in explosive risk areas
Trained persons	<ul style="list-style-type: none"> ■ Storage ■ Transportation ■ Control ■ Fault rectification

Tab. 4: Personnel qualification

3 Intended use

3.1 Notes on product warranty

Any non-designated use of the product can compromise its function or intended protection. This leads to invalidation of any warranty claims!

Please note that liability is on the side of the user in the following cases:

- The dosing pump is operated in a manner which is not consistent with these operating instructions, particularly safety instructions, handling instructions and the section "Intended Use".
- if people operate the product who are not adequately qualified to carry out their respective activities.
- no original spare parts or accessories of Lutz-Jesco GmbH are used.
- Unauthorised changes are made to the device.
- The user uses different dosing media than those indicated in the order.
- The user does not use dosing media under the conditions agreed with the manufacturer such as modified concentration, density, temperature, contamination, etc.

3.2 Intended purpose

The dosing pump MEMDOS KMS LB/LA is intended for the following purpose: the conveying and dosing of liquids.

3.3 Principles

- Before delivery, the manufacturer inspected the dosing pump and operated it under specific conditions (with a specific dosing medium with a specific density and temperature, with specific pipe dimensions, etc.) Since these conditions differ at every location of usage, the delivery capacity of the dosing pump should be measured by gauging it at the operating company's installation. For details on the approximate values and the capacity of the dosing pump, refer to the chapter 15 „Delivery characteristic curves“ on page 40.
- Comply with the information regarding the operating and environmental conditions (see chapter 5 „Technical data“ on page 13).
- Any restrictions regarding the viscosity, temperature and density of dosing media must be followed. You must only use dosing media at temperatures above freezing point or below the boiling point of the respective medium.
- The materials of the dosing pump and hydraulic parts of the system must be suitable for the dosing medium that is used. In this connection, note that the resistance of these components can change in dependence on the temperature of the media and the operating pressure.



Information on the suitability of materials combined with different dosing media can be found in the Compatibility Chart of Lutz-Jesco GmbH.

The information in this resistance list is based on information from the material manufacturers and on expertise obtained by Lutz-Jesco from handling the materials.

As the durability of the materials depends on many factors, this list only constitutes initial guidance on selecting material.

In all cases, test the equipment with the chemicals you use under operating conditions.

- The dosing pump is not intended for outdoor use unless appropriate protective measures have been taken.
- Avoid leaks of liquids and dust into the casing and avoid direct exposure to sunlight.
- You must never operate dosing pumps in a potentially explosive atmosphere if they do not have corresponding nameplates or an appropriate EC Declaration of Conformity for potentially explosive atmospheres.

3.4 Prohibited dosing media

The dosing pump must not be used for these media and substances:

- Gaseous media
- Radioactive media
- Solid substances
- Flammable media, if adequate protective measures are not taken
- All other media that are not suitable for delivery using this dosing pump

3.5 Foreseeable misuse

Below, there is information about the applications of the dosing pump or associated equipment that are not considered to be intended use. This section is intended to allow you to detect possible misuse in advance and to avoid it.

Foreseeable misuse is assigned to the individual stages of the product lifetime:

3.5.1 Incorrect assembly

- Unstable or unsuitable bracket
- Dosing pump bolted wrongly or loosely

3.5.2 Incorrect hydraulic installation

- Suction and pressure lines dimensioned incorrectly
- Unsuitable connection of the pipes due to wrong material or unsuitable connections.
- Suction and pressure lines mixed-up
- Damage to threads due to them being tightened too much
- Bending of pipelines
- No free return flow of the pressure relief valve
- Excessive demand due to the pressure differences between the suction and pressure valves
- Through-suction at installation without back-pressure valves
- Damage due to undamped acceleration mass forces
- Exceeding the admissible pressure on the suction and discharge sides
- Using damaged parts

3.5.3 Incorrect electrical installation

- Connecting the mains voltage without a protective earth
- Unsecured mains or one that does not conform to standards
- Not possible to immediately or easily disconnect the power supply
- Wrong connecting cables for mains voltage
- Dosing pump accessories connected to wrong sockets
- Protective earth removed

3.5.4 Incorrect start-up

- Start-up with damaged system
- Shut-off valves closed at commissioning
- Closed suction or pressure line, e.g. due to blockages
- Personnel was not informed before the start-up
- System was recommissioned after maintenance without all the protective equipment and fixtures, etc. being reconnected.
- Inadequate protective clothing or none at all

3.5.5 Incorrect operation

- Protective equipment not functioning correctly or dismantled
- Modification of the dosing pump without authority
- Ignoring operational disturbances
- Elimination of operational disturbances by personnel without adequate qualifications
- Deposits in the dosing head due to inadequate purging, particularly with suspensions
- Bridging the external fuse
- Operation made more difficult due to inadequate lighting or machines that are difficult to access
- Delivery of dosing media for which the system is not designed
- Delivery of particulate or contaminated dosing media
- Inadequate protective clothing or none at all
- If the pump is operated with a blocked suction line, cavitation occurs, which eventually leads to a rupture of the hose-diaphragm.
- Do not operate the pump with low or no back pressure. If the back pressure is too low, the hose diaphragm will not return to its original position. This event stretches the diaphragm to a point at which it

bursts.

3.5.6 Incorrect maintenance

- Carrying out maintenance during ongoing operation
- Carrying out work that is not described in the operating manual
- No adequate or regular inspection of correct functioning
- No replacement of damaged parts or cables with inadequate insulation
- No securing against reactivation during maintenance work
- Using cleaning materials that can cause reactions with the dosing media
- Inadequate cleaning of the system
- Unsuitable purging medium
- Unsuitable cleaning materials
- Detergents left in system parts
- Using unsuitable cleaning equipment
- Using the wrong spares or lubricants
- Contaminating the dosing medium with lubricant
- Installing spare parts without following the instructions in the operating manual
- Blocking venting orifices
- Pulling off sections of the plant
- Contamination at installation without a dirt trap
- Mixing up the sensor lines
- Not reconnecting all the lines
- Damaging or not installing all the seals
- Not renewing seals
- Not paying attention to safety data sheets
- Inadequate protective clothing or none at all

3.5.7 Incorrect decommissioning

- Not completely removing the dosing medium
- Dismantling lines while the dosing pump is running
- Device not disconnected from the power supply
- Using the wrong dismantling tools
- Inadequate protective clothing or none at all

3.5.8 Incorrect disposal

- Incorrect disposal of dosing media, operating resources and other materials
- No labelling of hazardous substances

4 Product description

4.1 Properties

The MEMDOS KMS LB/LA is a dosing pump with hydraulically deflected diaphragm.

They are characterized by the following properties:

- Performance range of 14 to 700 l/h with a backpressure of 10 – 200 bar
- Reproducible dosing precision of $\pm 1\%$
- Stroke length manually adjustable between 0 % and 100 %
- Stainless steel dosing heads
- CSM and FPM seals available
- Suitable for highly aggressive or poisonous dosing media,
- Protected against overpressure through integrated safety valve
- MEMDOS KMS LA with additional features:
 - Stroke frequency settable 0 – 100 % using the potentiometer
 - Operation of the pump via the operating panel
 - Signal LEDs for status, operating and error display
 - Clearance input for external start/stop
 - Analogue input and output: 0/4 – 20 mA
 - Level input with main alarm
 - Alarm relay output
 - Stroke feedback output

4.2 Scope of delivery

Please compare the delivery note with the scope of delivery. The following items are part of the scope of delivery:

- Dosing pump MEMDOS KMS LB/LA
- Operating instructions
- Oil container
- Inspection report and test certificate (optional)
- Accessory kit (optional)

4.3 Structure MEMDOS KMS LB/LA

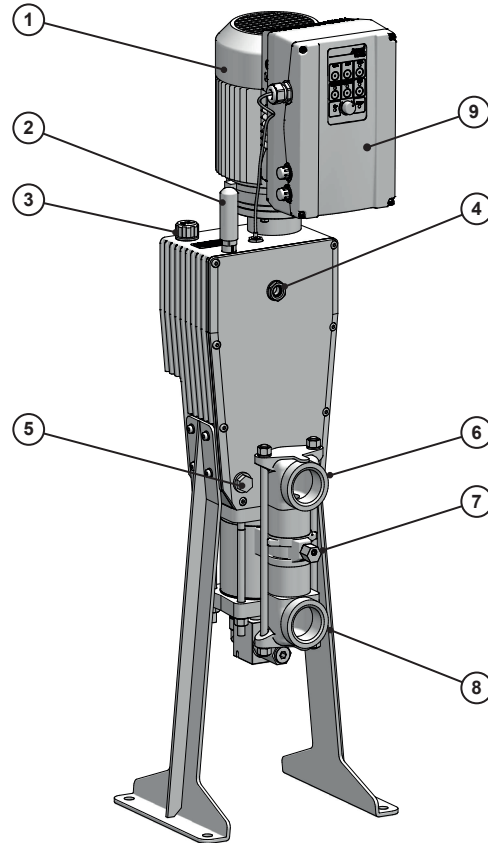

Fig. 1: Overview dosing pump MEMDOS KMS LB/LA

Item	Description
1	Drive motor
2	Stroke length adjustment
3	Oil inlet
4	Oil level glass
5	Oil drain
6	Connection discharge side
7	Dosing head ventilation
8	Connection suction side
9	Control (only LA)

Tab. 5: Designation of components

4.4 Control elements MEMDOS KMS LA

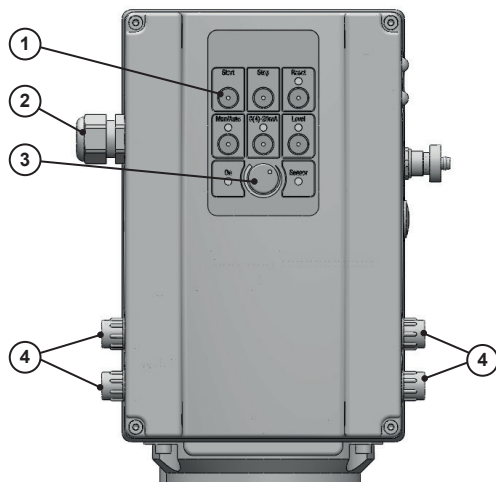

Fig. 2: Control elements

Item	Description
1	multifunction buttons
2	Power supply connection
3	Potentiometer
4	Connection sockets for external operation or connecting accessories

Tab. 6: Designation of the control elements

4.5 Function description MEMDOS KMS LB/LA

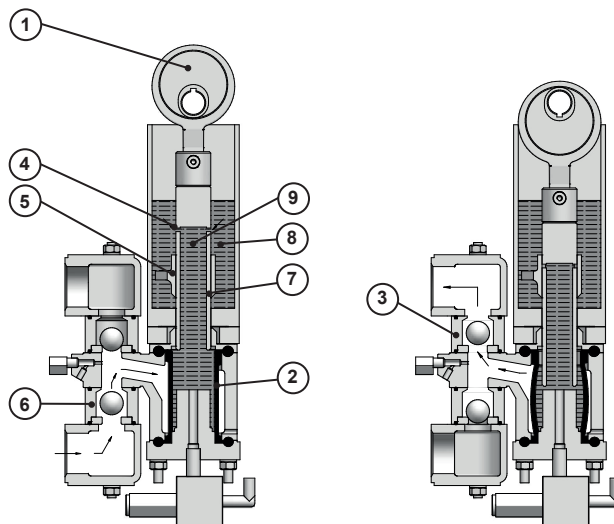

Fig. 3: Cross section MEMDOS KMS LB/LA dosing head (left: suction stroke, right: pressure stroke)

No.	Description
1	Connecting rod
2	Hose diaphragm
3	Pressure valve
4	Discharge opening

Tab. 7: Pos. numbers dosing head MEMDOS KMS LB/LA

No.	Description
5	Slide valve
6	Suction valve
7	Piston
8	Reservoir
9	Oil

Tab. 7: Pos. numbers dosing head MEMDOS KMS LB/LA

Dosing units for the dosing of liquids are usually dosing pumps with an oscillating or rotating displacement body. The MEMDOS KMS LB/LA works with an oscillating piston driven via a worm gear by an electrical motor. The worm gear and the hydraulic system of the pump are operated using the same oil (9).

An eccentric in the pump housing is put into rotation by a worm gear. The eccentric is connected with the piston (7) via a connecting rod (1) and converts the rotation movement of the motor into an oscillating movement of the piston. If the piston moves downwards, the hydraulic fluid in the pump is pressurized. This stretches the hose diaphragm (2) and the medium in the dosing head is pressed out via the pressure valve (3). The piston is equipped with an axial flow opening at its lower end; this concludes in a radial discharge opening (4) at its upper end. A downwards piston movement following a set partial stroke (stroke adjustment unit) works to displace the hydraulic fluid through the flow opening into the reservoir (8) next to the piston. The actual delivery rate is set via a slide valve (5) which is positioned vertically using a control rod. As long as the radial opening in the piston is not covered by the slide valve, the displaced hydraulic fluid moves upwards, back through the flow opening into the hydraulic fluid chamber and no process fluid is transported. If the piston moves downwards whilst the radial opening is covered by the slide valve, hydraulic fluid cannot escape through this opening and the hose diaphragm will be stretched to its maximum extent. If the piston reaches its lower end position and starts to return upwards, the hose diaphragm will relax to its original position. The resulting negative pressure in the dosing head effects suction of the process fluid through the suction valve (6). The hose diaphragm returns from its extension to a fixed position with every stroke. This position represents a perforated support pipe, which secures unchanging accuracy by maintaining the end position of the diaphragm. If the piston reaches the upper end position, a pump cycle has been completed and the next cycle can begin. The hydraulic reservoir and the dosing head are designed to remove any developing gas bubbles (foam) with every stroke. This is achieved in the pump housing by the ability of the gas bubbles to rise through the piston into the chamber. In the dosing head itself, the opening of the flow channel rises continually to the pressure valve without impediments for the gas bubbles. To fill and vent the hydraulic system with every stroke, the upper position of the slide valve is applied in such a way that the radial opening in the piston is opened for a certain part of the piston movement.

4.6 Rating plate

There is information on the equipment about safety or the product's way of functioning. The information must stay legible for the duration of the service life of the product.

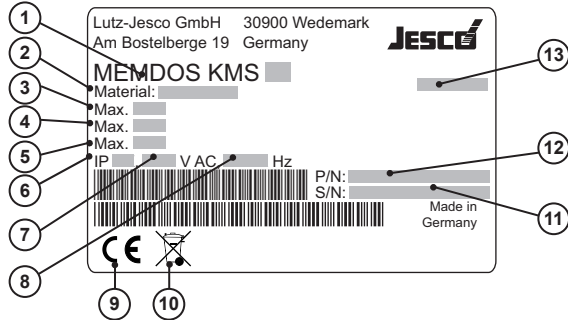

Fig. 4: Rating plate MEMDOS KMS LB/LA

No.	Description
1	Product name
2	Material of the dosing head / seals
3	Maximum delivery capacity at maximum pressure at 50 Hz
4	Maximum delivery capacity at maximum pressure at 60 Hz
5	Maximum back pressure
6	Protection class
7	Voltage supply
8	Frequency
9	Label showing conformity with applicable European directives
10	WEEE label
11	Serial number
12	Part number
13	Month/year of manufacture

Tab. 8: Rating plate

5 Technical data

Please note that some of this data only represents guide values. The actual capacity of a dosing pump depends on various factors.

5.1 Delivery capacity data

MEMDOS KMS LB/LA		14	20	30	60	100	140	200	285	400	320	500	700
Delivery capacity at max. back-pressure	l/h	13.5	21	29.4	63.5	98.8	138	203	284	396	320.9	499.2	697
max. delivery pressure	bar	200			50			20			10		
Max. stroke frequency	rpm	83	130	181	83	130	181	83	130	181	83	130	181
Suction lift for non-gassing media	mWs	2											

Tab. 9: Delivery capacity data MEMDOS KMS LB/LA

5.2 Operating conditions and limits

MEMDOS KMS LB/LA		14	20	30	60	100	140	200	285	320	400	500	700
Approved ambient temperature	°C	5 – 80*											
Relative humidity	%	max. 90											
Max. sound pressure level	dB(A)	57 – 65											
Max. supply pressure	mbar	500											
Viscosity limits	mPa·s	300** / 1000***											
Adjustable dosing range	%	0 – 100											

Tab. 10: Operating conditions and limits MEMDOS KMS LB/LA

* Use of the dosing pump at ambient temperatures below 5 °C must be checked individually. In such cases, please contact the manufacturer.

** With a viscosity of ~300 mPa·s and above, you must use spring-loaded valves.

*** If the viscosity is above 1000 mPa·s, this must be checked individually and the stroke frequency must be between 50 and 100 strokes/min.

5.3 Other data

MEMDOS KMS LB/LA		14	20	30	60	100	140	200	285	400	320	500	700
Weight	kg	49			51.6			56.6			64.6		
Diameter of the piston	Inch	1/2			1			1 1/2			2		
Stroke length	mm	20											
Protection class		IP55											
Nominal valve width		DN10			DN15			DN20			DN30		

Tab. 11: Other data MEMDOS KMS LB/LA

5.4 Motor data

5.4.1 400 V /230 V three-phase motors

MEMDOS KMS LB			14	20	30	60	100	140	200	285	400	320	500	700
Power output	kW	50 Hz	0.75											
		60 Hz	0.86											
Speed	rpm	50 Hz	1400											
		60 Hz	1700											
Nominal current	A	50 Hz	1.8											
		60 Hz	1.72											
Voltage	V3~	50 Hz	400 / 230											
		60 Hz	460 / 270											
Mains voltage		DIN EC 60038												
Frequency	Hz	50 / 60												
Operating mode		S1												
Protection class		IP55												
Insulation class		F												
Size		80												
Flange Diameter	mm	120												
Shaft	mm	19 x 40												
Cooling		IC 411												
Weight	kg	13												

Tab. 12: 400 V /230 V three-phase motors MEMDOS KMS LB

5.4.2 400 V / 230 V three-phase motors with frequency converter

MEMDOS KMS LB		14	20	30	60	100	140	200	285	400	320	500	700
Power output	kW	50 Hz	1.10										
		60 Hz	1.30										
Speed	rpm	50 Hz	1440										
		60 Hz	1740										
Nominal current	A	50 Hz	2.43										
		60 Hz	2.35										
Voltage	V3~	50 Hz	400 / 230										
		60 Hz	460 / 270										
Mains voltage		DIN EC 60038											
Frequency	Hz	50 / 60											
Operating mode		S1											
Protection class		IP55											
Insulation class		F											
Size		80											
Flange Diameter	mm	120											
Shaft	mm	19 x 40											
Cooling		IC 411											
Weight	kg	13											

Tab. 13: 400 V / 230 V three-phase motors with frequency converter MEMDOS KMS LB

5.4.3 230 V / 120 V alternating current motors with operating capacitor

MEMDOS KMS LB		14	20	30	60	100	140	200	285	400	320	500	700
Power output	kW	0.75											
Speed	rpm	50 Hz	1440										
		60 Hz	1680										
Nominal current	A	50 Hz	5										
		60 Hz	11.1										
Voltage	V1~	230 / 120											
Mains voltage		DIN EC 60038											
Frequency	Hz	50 / 60											
Operating mode		S1											
Protection class		IP55											
Insulation class		F											
Size		80											
Flange Diameter	mm	120											
Shaft	mm	19 x 40											
Cooling		IC 411											
Weight	kg	13											

Tab. 14: 230 V / 120 V alternating current motors with operating capacitor MEMDOS KMS LB

5.5 AC drive 120 V or 230 V

MEMDOS KMS LA		14	20	30	60	100	140	200	285	400	320	500	700
Power output	kW	1.10											
Speed	rpm	1500											
Nominal current	A	max. 9.2											
Voltage	V1~	208 / 230											
Mains voltage		DIN EC 60033											
120 V (208 V) version		CSA and UL certified											
Frequency	Hz	50 / 60											
Operating mode		S1											
Protection class		IP55											
Insulation class		F											
Size		80											
Flange Diameter	mm	120											
Shaft	mm	19 x 40											
Cooling		IC 411											
Weight	kg	17											
Electrical cable	m	1.8 m (with mains plug)											

Tab. 15: AC drive 120 V or 230 V MEMDOS KMS LA

6 Dimensions

All dimensions in mm

6.1 MEMDOS KMS LB/LA

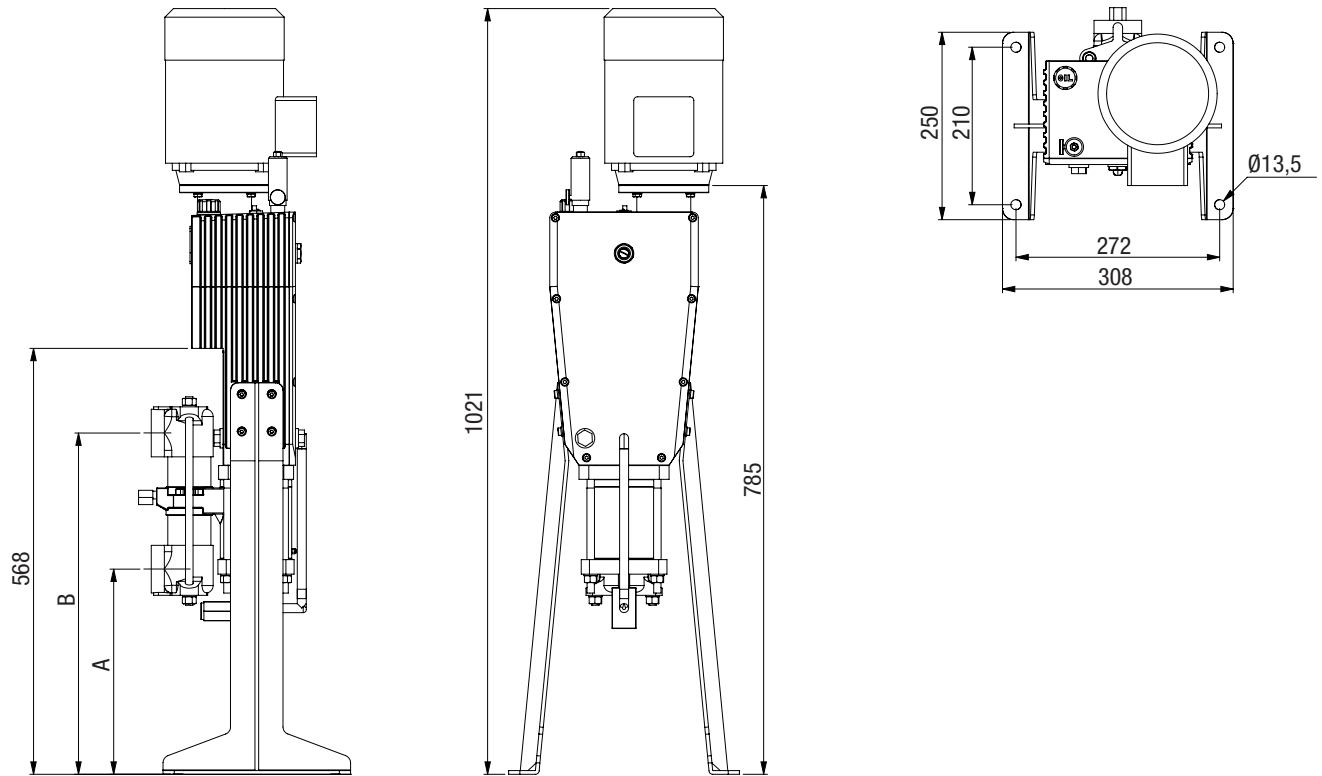

Fig. 5: Dimensional drawing MEMDOS KMS LB/LA

Size dosing head	A	B
0,5"	325.2	438.3
1"	305.9	458.2
1,5"	271.7	453.2
2"	224.2	401.7

Tab. 16: Dimensions MEMDOS KMS LB/LA

7 Installing the Dosing Pump



DANGER!

Mortal danger from electric shock!

Electrically conductive liquid can enter pump housings, cable screw connections and mains connectors.

- ⇒ Make sure that all protective measures comply at least with the requirements of protection class IP65.
- ⇒ Always set up the dosing pump such that water cannot enter the housing.



CAUTION!

Danger of personal injury and material damage!

A dosing pump that is difficult to access represents a danger due to incorrect operation and faulty maintenance.

- ⇒ Install the dosing pump such that it is accessible at all times.

7.1 Set up information

When installing, follow the basic principles below:

- The dosing heads are standardly fitted in a certain direction (see Fig. 5: Dimensional drawing MEMDOS KMS LB/LA“ on page 17). The 1.5“ and 2“ dosing heads can also be fitted in the opposite direction.
- You should install the dosing pump at a convenient height for operation.
- It must not be fitted to a wall without a wall console.
- The frame of foundation for fixing the dosing pump must not be subjected to jolts. The pump must be vibration-free and stable.
- There must be enough free space in the area of the dosing head and the suction and pressure valves for these parts to be easily dismantled if required. The entire space requirement for installation and maintenance is approximately 1 m².
- The distance from the sides of the dosing pump to the wall or other dosing pumps or equipment must be at least 3 cm. There must be a guaranteed flow of circulating air.
- The maximum ambient temperature must be complied with, see chapter 5.2 „Operating conditions and limits“ on page 13. If necessary, radiant heat from surrounding equipment must be screened.
- Avoid exposure to direct sunlight.
- The dosing pump is not intended for use out of doors unless appropriate protective measures have been taken to prevent dust and water from entering the housing.
- For the dimensions of the fastening holes, refer to chapter 6 „Dimensions“ on page 17.
- Install the dosing pump on a level surface.

7.2 Installation on a wall console

If necessary, the dosing pump can be mounted on a wall bracket or a base. To this end, the MEMDOS KMS LB/LA is fitted with a fixture (1) on the rear, offset edge. This means that the pump can be fixed to a suitable surface or bracket with two M10 screws.

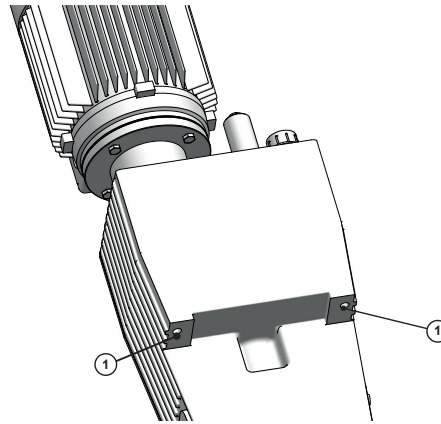

Fig. 6: Installation on a wall console

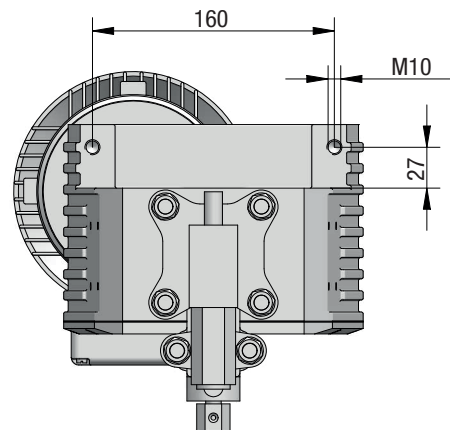





Fig. 7: Dimensional drawing installation on a wall console

8 Hydraulic installations

In this chapter, you will find information about the hydraulic parts of a system that you should install or that can install additionally. In many cases, you must install hydraulic accessories to be able to guarantee functional safety or to achieve a high level of dosing precision.

	WARNING
<p>Caustic burns or other burns through dosing media!</p> <p>A diaphragm rupture, blocked pressure lines or the use of material not suitable for the dosing medium can result in the discharge of dosing medium. Depending on the type and hazardousness of the dosing medium, this can result in injury.</p> <ul style="list-style-type: none"> ⇒ Wear the recommended personal protective equipment. ⇒ Make sure that the materials you are using are suitable for the dosing medium. ⇒ Make sure that the lubricants, adhesives, sealants, etc. that you use are suitable for the dosing medium. ⇒ Install a leakage drain. ⇒ Install pressure relief valves. 	

	CAUTION!
<p>Danger of personal injury and material damage!</p> <p>High peak pressures can lead to piping vibrating and cause them to snap. This can result in injury from piping or escaping dosing media.</p> <ul style="list-style-type: none"> ⇒ Install pulsation dampeners. 	

	PLEASE NOTE
<p>Damage to drives due to overloading</p> <p>The pressure conditions between the suction and discharge sides must be balanced; otherwise, overloading can result. This can lead to uncontrolled dosing processes and damage to the piping as well as to the dosing pump.</p> <ul style="list-style-type: none"> ⇒ Ensure that the pressure on the discharge side is at least 1 bar than on the suction side. 	

	PLEASE NOTE
<p>Locking of threads</p> <p>Stainless steel and plastic parts (particularly those made of PVC) that are bolted together in a detachable connection (e.g. the dosing head and the valves) can lock. This makes them difficult to release.</p> <ul style="list-style-type: none"> ⇒ Before bolting, grease the corresponding parts with a lubricant (e.g. PTFE spray). Ensure that the lubricant is compatible with the dosing medium. 	

Warning notice for installation in an explosive risk zone:

	DANGER!
<p>Danger to life through explosions!</p> <p>Systems without a pressure relief valve fitted produce an increased safety risk in an explosive risk zone. Explosions could occur if system parts heat up during an overload or by sparks which may be created if drive parts were to break.</p> <ul style="list-style-type: none"> ⇒ Install a pressure relief valve on the pressure side of the dosing pump. 	

8.1 Design of the system

- The dosing pumps technical data (see chapter 5 „Technical data“ on page 13) must be taken into account and the plant's layout must be set up appropriately (e.g. pressure loss when rating the lines with regard to their nominal diameter and length).
- The entire system and its integrated dosing pump must be designed in such a way that an escaping dosing medium (due to the failure of wearing parts such as the diaphragm, or burst hoses) does not lead to permanent damage to system parts or the premises.
- If you use hazardous dosing media, the installation must be designed such that no disproportionately high consequential damages arise due to dosing media escaping.
- To avoid dosing errors after the end of the process, the dosing pump must be locked hydraulically.
- To allow you to easily inspect the pressure conditions in the system, you should provide connections for pressure gauges close to the suction and pressure valves.

8.2 General installation

- All piping must be fixed. The system piping must not exert any force on the connections and valves of the dosing pump.
- Clean and blow out all piping before connecting the piping to the pump.
- Apply pipe sealant economically and only to the external threads.
- Do not connect pipes whilst the dosing head connections are connected to the pump.
- The suction line may not be smaller than the pump connections.
- The suction line should be straight and maintained as short as possible. It should also be fitted with the minimum possible number of bends, T-pieces and other fittings.
- To ensure easier pump maintenance, we recommend installing shut-off valves: Do not install a shut-off valve between the pressure connection and the system pressure control valve.
- Installing a screen in front of the suction line provides protection against foreign bodies.
- The process system requires a separate safety valve to protect it against excessive pressure. You should maintain an adequate safety factor in plastic piping systems.
- The installation of a bypass valve facilitates venting when starting a pump, in order to permit the re-circulation procedure of the fluid back to the tank.

8.3 System piping

- This means that steel piping should be connected to the dosing pump via flexible pipe sections.
- The nominal diameters of the pipework and the installed fittings should be rated the same as or greater than the nominal diameters of the dosing pump's suction and pressure valves.
- The suction line should be kept as short as possible.
- You should avoid intertwined hoses.
- Avoid loops, since air bubbles can collect.



CAUTION!

Danger of personal injury and material damage!

Before connecting connection pipes and fittings, first remove the dosing head connections, otherwise unnecessary forces will impinge upon the piping system.

⇒ Remove the dosing head connections before connecting the connection pipes and fittings.

8.4 Suction and pressure valves

These are single- or double-ball bearing or spring-loaded valves which can only work properly when mounted in a vertical direction. The condition of the valves has a significant impact on the function and the dosing accuracy of the dosing pump. All valves have arrows on them, these indicate the flow direction. These arrows must always point upwards.

8.5 Hydraulic accessories

The following chapter is intended to give you an overview of installation options.

Please note that these operating instructions are no substitute for the instructions supplied with the accessories in each case. The corresponding documentation supplied with the product applies to safety information and provides exact instructions on assembly.

8.5.1 Injection nozzle

If the pressure line enters a main line, it is advisable to install an injection nozzle.

Injection nozzles have three main functions:

- Dosing the medium into a main line
- Preventing flowback into the pressure line through a non-return valve

Notes on assembly:

- Double-ball injection nozzles must be installed into the main line vertically from the bottom. You can install hose and spring-loaded injection nozzles any way you like.
- With dosing media that tend to crystallize, it is advisable to carry out installation into the main line from the bottom. This prevents the inclusion of air bubbles.
- Many dosing media tend to contaminate the injection nozzles, which can lead to blockages. In cases like this, it is advisable to install an injection nozzle that is easy to dismantle and block off.

8.5.2 Pressure-relief valve

Pressure relief valves have an important safety function for protecting the dosing pump and the associated pipes and fittings. The dosing pump can generate a pressure that is many times the rated one. A blocked pressure line can lead to dosing medium escaping.

Impermissibly high pressure can develop as follows:

- the shut-off valves are closed even though the dosing pump is running,
- pipes block.

At an appropriate pressure, a pressure relief valve opens a bypass line and protects the system in this way from damage caused by over-pressure.

Notes on assembly:

- The line for returning dosing medium from the pressure relief valve must be routed to the dosing tank or to a collecting pan.
- The pressure in the dosing tank must not be too high so that it is possible to accommodate the returned dosing medium.
- As an alternative, the system can return dosing medium into the suction line in front of the dosing pump. In this case, there must not be a non-return valve or a foot valve in the suction line.
- You should install the pressure relief valve as close as possible to the dosing head.

8.5.3 Back-pressure valve

Back-pressure valves are required in the following cases:

- There are considerably fluctuating system pressures

- The pressure on the suction side is higher than on the discharge side or if you intend to carry out dosing into depressurized lines

In cases like this, if you do not use a back-pressure valve, imprecise dosing results will occur or overloading will result. The back-pressure valve solves these problems by generating a defined, constant backpressure.

In some circumstances, a back-pressure valve is unnecessary if you use a hose injection nozzle and if the backpressure that it generates is adequate.

8.5.4 Pulsation dampener

Pulsation dampeners have the following functions:

- Damping pulsating delivery flows for processes that require low-pulsation dosing
- Reducing the throughflow resistance with long pipelines

When installed on the suction side:

- Damping of acceleration mass forces and with this reduction of wear on the dosing pump
- Preventing cavitation (pull-off of the liquid column) due to too high acceleration

However, pulsation dampeners also have important safety functions, since they prevent pressure peaks from arising that lead to piping vibrating and cause them to snap.

This problem might occur in the following cases:

- With the high amplitudes of the vibrations
- When using long pipes (the severity of the pulsation increases with the length of the pipe)
- When using rigid piping instead of elastic hoses

Notes on assembly:

- You should carry out assembly in the direct vicinity of the location where you want to damp the pressure peaks (directly in front of the suction valve or directly behind the pressure valve).
- Pulsation dampeners should be installed with throttle valves or back-pressure valves installed directly behind them. By setting the valves appropriately, you can further-optimize damping of the pulsations.
- To prevent unnecessary pipe friction losses, you should lay the connecting line straight and in accordance with the rated width of the pulsation dampener.
- You must separately fasten relatively large pulsation dampeners and ones with hose connections.
- Pipelines must not transfer any mechanical tensions onto the pulsation dampener.

8.5.5 Priming aid

Priming aids are particularly advisable:

- in the case of dosing pumps with small volumetric displacements per stroke or with low stroke length settings
- With high suction heights
- With highly dense dosing media
- At priming for the first time due to dry valves and air in the suction line and the dosing head
- In dosing systems with frequent downtimes

Further advantages through priming aids:

- Preventing cavitation in the suction line
- Gas removal
- Optical dosing control with small amounts
- Smoothing of the suction flow

8.5.6 Dosing of suspensions

When dosing suspensions, the dosing head must be rinsed regularly to prevent depositing. To do this, you install a feed line for the rinsing medium (water) in the suction side installation.

8.5.7 Suction pressure regulator

A suction pressure regulator may be necessary if the suction-side installation of the system demonstrates a varying suction pressure or supply pressure:

- Dosing pumps that are installed above dosing tanks deliver less as the tank empties, since the suction head increases.
- Dosing pumps that are installed below dosing tanks deliver less as the tank empties, since the positive delivery pressure reduces.

Further problems that can occur:

- Greater wear on the dosing pump, e.g. diaphragm rupture due to the effects of heavy forces with particularly high tanks and high-density dosing media.
- Idling of the dosing tank in the case of a diaphragm rupture or pipe breakage.
- Impermissibly high forces in the pump transmission that occur when dosing pumps receive the dosing medium directly from the pressure line.
- Reduced performance or destruction of fittings due to cavitation with long suction lines.

Installing a suction pressure regulator is a remedy for the problems above. The suction pressure regulator is opened by the dosing pump's suction pressure. This ensures that no dosing medium can flow if the dosing pump is not running or no vacuum can be generated following a pipe fracture.

Notes on assembly:

- When using a large suction pressure regulator, you should provide a pulsation dampener on the suction side.
- Installation examples are not shown in the explanations of the accessories.

9 Electrical installation

DANGER!

Mortal danger from electric shock!

If there is an electrical accident, you must disconnect the dosing pump from the mains as quickly as possible.

⇒ Install an emergency stop switch or integrate the dosing pump into the plant safety concept.

CAUTION!

Danger of automatic start up!

The dosing pump does not have an ON/OFF switch and may start to pump as soon as it is connected to the mains supply. This means that dosing medium can escape. Depending on the type and hazardousness of the dosing medium, this can result in damage to property or to injury.

⇒ Install an emergency stop switch or integrate the dosing pump into the plant safety concept.

PLEASE NOTE

Damage due to incorrect mains voltage

The dosing pump can be damaged if you connect it to the wrong mains voltage.

⇒ Observe the information on the mains supply that is given on the rating plate.

Safety instructions for installation in a potentially explosive atmosphere:

DANGER!

Danger to life through explosions!

Explosions may result which could result in fatal injuries.

⇒ Earth the dosing pump, drive motor and all metal parts along the suction and pressure piping route.

9.1 Drive motor connection

- The electrical connection comply with local regulations.
- Cable type and cross-section of the supply lines must be chosen according to the motor data.
- We recommend to use cable screw connections with strain-relief clamps.
- The required protection degree must be ensured by installing the connections professionally.
- The motor must be protected by a suitable motor protection switch.

- The dosing pump must be earthed via a PE conductor for the connection to the termination box.
- If an ATEX certified motor is being used, you must also observe the enclosed motor operating instructions.
- The motor must be connected to the termination box in accordance with the circuit diagram.

9.1.1 Three-phase motors

Connection	Phases	MEMDOS KMS LB/LA
<p style="text-align: center;">Star connection</p>	3 ~	14–700
<p style="text-align: center;">Delta connection</p>	3 ~	14 – 700

Tab. 17: Three-phase motors circuit diagrams

9.1.2 Rotational direction of the motor

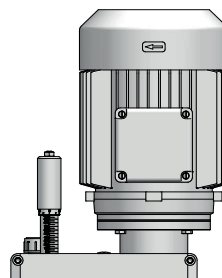

Fig. 8: Top view rotational direction of the motor

Comply with the rotation direction! The arrow indicates the rotational direction of the motor which should be set-up.

9.2 Description of connection sockets MEMDOS KMS LA

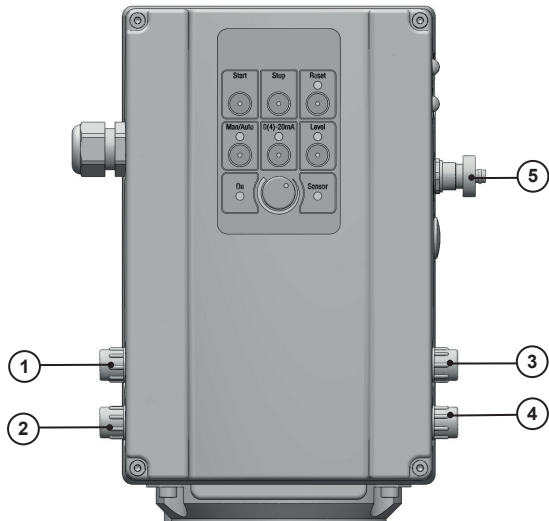

Fig. 9: Connection sockets 1 – 5

Connection	Input
1	Release input
2	Analogue input 0/4 – 20 mA
3	Level input

Tab. 18: Inputs of the control unit

Connection	Output
1	Stroke feedback output
2	Analogue output 0/4 – 20 mA
4	Fault reporting relay output

Tab. 19: Inputs of the control unit

Connection	Programming connection
5	Programming connection (for factory settings)

Tab. 20: Inputs of the control unit

9.2.1 Connection socket 1

9.2.1.1 Stroke feedback

All strokes are registered in the pump via a separate stroke counter; this is outputted via the stroke feedback output.

The stroke feedback output is used to evaluate the signal in a PLC (stroke counting for batch mode). The signal can also be used to detect the pump run.

One contact is closed per stroke and a 24 V DC voltage signal is issued.

- Closer NO
- Short-circuit proof
- Load capacity: max. 20 mA

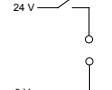
Pin	M12x1 (A-coded)	Assignments	Connection	Cable colour*	
2		DIG OUT 1 (24 V out)		White	WH
1		GND		0 V	Brown

Tab. 21: Connection socket 1

* Applies to cable colours from Lutz-Jesco GmbH. No liability is accepted for cables from other manufacturers.

9.2.1.2 Release input

Using the Release input, it is possible to start or stop the dosing pump externally. The contact is open when not switched. 24 V DC are applied to pin 4. Connection with an external switch enables closure of the contact, thus withholding clearance.

- Closer NO
- I_{max} (with 24 V) = 3 mA
- Switching level high > 15 V DC

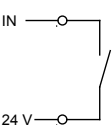
Pin	M12x1 (A-coded)	Assignments	Connection	Cable colour*	
3		DIG IN 1		Blue	BU
4		24 V DC OUT		24 V	Black

Tab. 22: Release input

* Applies to cable colours from Lutz-Jesco GmbH. No liability is accepted for cables from other manufacturers.

9.2.2 Connection socket 2

9.2.2.1 Analogue input

The analogue input makes it possible to control the delivery capacity by means of a 0/4 – 20 mA signal.

The delivery capacity is regulated via the stroke frequency.

- 0/4 - 20 mA signal
- Tolerance ± 2 %
- Working resistance: 500 ohms

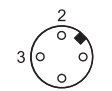
Pin	M12x1 (A-coded)	Assignments	Connection	Cable colour*	
2		(+) 0/4 – 20 mA	—○2	White	WH
3		Analogue (GND)	—○3	Blue	BU

Tab. 23: Analogue input

* Applies to cable colours from Lutz-Jesco GmbH. No liability is accepted for cables from other manufacturers.

9.2.2.2 Analogue output

The dosing pump relays an analogue signal via the analogue output; its current value behaves in proportion to the delivery capacity set. With 0 % delivery capacity, 0 mA or 4 mA is registered. With 100 % delivery capacity, the output signal amounts to 20 mA.

- 0/4 – 20 mA signal
- Tolerance ± 2 %

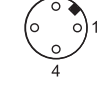
Pin	M12x1 (A-coded)	Assignments	Connection	Cable colour*	
1		0/4 – 20 mA	—○1	Brown	BN
4		Analogue (GND)	—○4	Black	BK

Tab. 24: Analogue output

* Applies to cable colours from Lutz-Jesco GmbH. No liability is accepted for cables from other manufacturers.

9.2.3 Connection socket 3

9.2.3.1 Level input

The dosing pump can be connected with an external level contact (e.g. a suction line with a level switch) via the level input. The contact is open when not switched. 24 V DC are always applied to pin 3. If the float falls with a falling level, a contact is switched and the pump comes to a standstill. The alarm relay is also switched and the level and alarm LEDs illuminate.

- Closer NO
- I_{max} (with 24 V) = 3 mA
- Switching level high > 15 V DC

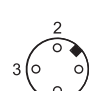
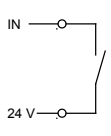
Pin	M12x1 (A-coded)	Assignments	Connection	Cable colour*	
2		DIG IN 2		White	WH
3		24 V OUT		Blue	BU

Tab. 25: Level input

* Applies to cable colours from Lutz-Jesco GmbH. No liability is accepted for cables from other manufacturers.

9.2.4 Connection socket 4

9.2.4.1 Alarm relay output

Faults of the dosing pump can be outputted via the alarm relay. An alarm LED lights up as soon as a fault is registered. The LED begins to flash once the fault has been remedied and the error can be cleared.

- potential-free
- With an ohmic resistive load: max. 230 V AC, 2.5 A / max. 30 V DC, 2.5 A

Possible faults:

- Level switch (empty notification)
- Stroke sensor
- Cable break
- Motor overload
- Damage to motor
- Drive defective

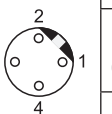
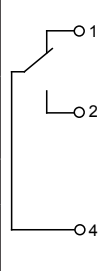
Pin	M12x1 (B-coded)	Assignments	Connection	Cable colour*	
1		Break (NC) contact		Brown	BN
2		Make (NO) contact		White	WH
3		-		Blue	BU
4		Changeover contact		Black	BK

Tab. 26: Alarm relay output

* Applies to cable colours from Lutz-Jesco GmbH. No liability is accepted for cables from other manufacturers.

10 Control

10.1 Stroke length adjustment

The desired delivery rate of the dosing pump is set using the stroke length adjustment. Turning the adjustment knob increases or decreases the hub length and so the amount of dosing media from the dosing head.

The stroke length can be adjusted while the pump is running or while it is turned off (in depressurized condition).

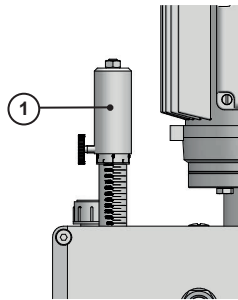

Fig. 10: Stroke length adjustment

The scale on the stroke length adjustment shows the value of the setting in percentage terms from 0 % (stopped) to 100 % (maximum possible stroke length).

10.2 Vent the dosing head

To vent the dosing head, it has a vent valve (1). Loosening the screw anti-clockwise can result in gas escaping from the dosing head. The dosing head should be entirely bubble-free. An additional hose can be clamped to the lower drill-hole to prevent uncontrolled leakage of the dosing medium during venting. If the dosing head has been completely vented, the valve must be closed.

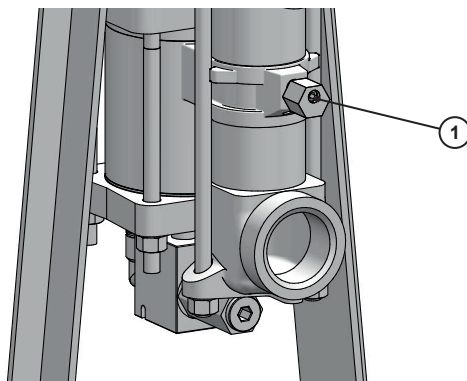

Fig. 11: Dosing head ventilation

10.3 Controllable safety valve of the dosing head

The MEMDOS KMS pumps are fitted with controllable safety valves as standard; this protects the dosing pump and the motor against damage from overloading (e.g. a closed slider in the pressure line).

This is a settable pressure-relief valve located on the lower dosing head adapter. The pressure-relief valve is set on the factory side to an outlet pressure of 20 % over the pressure which is specified on the rating plate.

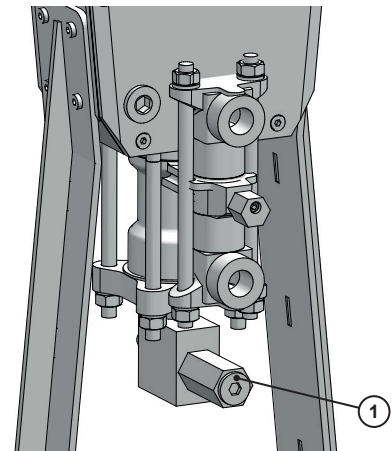

Fig. 12: Dosing head safety valve

Perform the following working steps:

1. Remove the cap of the adjustment screw (1).
2. To increase the outlet pressure, turn the adjustment screw clockwise step by step using an Allen key.
3. To reduce the exhaust pressure, turn the adjustment screw counter-clockwise.
4. Replace the cap. Make sure that the (metal) seal is in a good condition and has been installed in the reverse order.

The pressure in the pump develops at the lower end of the piston. If this pressure is higher than the set pressure force of the spring in the safety valve, the valve will open and the hydraulic fluid will be returned to the pump via the bypass.

i The chamber in which the safety valve is located must be free of air and completely flooded with oil, otherwise loud and strong vibrations can develop when the safety valve has been triggered. The lowest possible settable pressure is 200 psig (13.7 bar).

10.4 Operating panel MEMDOS KMS LA

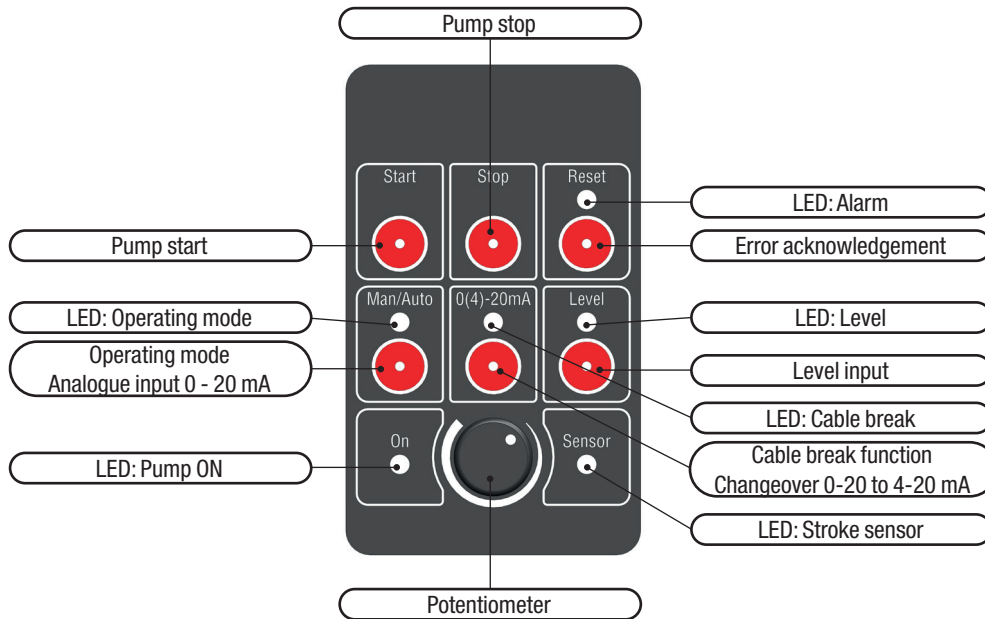

Fig. 13: Operating panel

10.5 General

- The pump must be restarted once the operating mode has been changed and the cable break function or the level input has been activated.
- The pump will not restart automatically after a error has been remedied and acknowledged. It must be restarted.
- If the pump was disconnected from the voltage supply in running operation, it restarts automatically once the voltage is returned.
- The Alarm LED is illuminated permanently if an error is registered. The LED begins to flash once the error has been remedied and must be cleared with **Reset**.
- The stroke sensor LED flashes whilst the pump is running. The LED illuminates once per stroke.
- The yellow LEDs Man/Auto, (0)4-20mA and Level only illuminated when switched.
- The pump implements the setting range 30 – 100 % in an infinity adjustable fashion via the potentiometer or an external mA signal. In the range 0 – 30 % the pump enters Start/Stop operation to achieve the desired delivery capacity.

10.6 Operating modes

The pump has two operating modes.

- Manual operation
- Automatic operation

10.6.1 Manual operation

The pump is in manual operation as standard. The delivery capacity of the pump can be set between 0 % and 100 % using the potentiometer. The pump can be started or stopped by pressing the **Start** or **Stop** key.

Precondition for action:

- ✓ The pump assembly and installation have been completed successfully.

Perform the following working steps:

1. Set the desired delivery capacity manually using the potentiometer.
 2. Press **Start**.
 - ▶ The On LED is lit.
- ✓ **The pump now runs in manual operation.**

10.6.2 Automatic operation

Pressing the **Man/Auto** key activates automatic operation. This enables the pump to be controlled via an external controller using an analogue signal between 0 – 20 mA.

Precondition for action:

- ✓ The pump assembly and installation have been completed successfully.

Perform the following working steps:

1. Press **Man/Auto** to change to automatic operation.
 - ▶ The Man/Auto LED illuminates. The pump can now be controlled by an external controller.
 2. Press **0(4)-20mA** to activate the cable break function in addition to automatic control.
 - ▶ The analogue signal to the external control must be between 4 – 20 mA. If the signal falls under 2 mA, the pump stops, the alarm relay is switched and the alarm LED and the cable break LED will illuminate.
 3. Press **Start**.
 - ▶ The On LED is lit.
- ✓ **The pump is now running in automatic operation and is controlled externally.**



The **0(4)-20mA** key will only function after automatic operation has been activated (analogue signal) and deactivates automatically after a change to manual operation.

10.7 Extended functions

The pump has two additional functions:

- Cable break
- Level monitoring

10.7.1 Cable break

The cable break function detects a damaged control cable. The external current signal is not longer sent to the pump correctly.

In home position, the analogue input has a setting range of 0 – 20 mA. The **0(4)–20mA** key alters the setting range to 4 – 20 mA. If the current value of the incoming signal lies under 2 mA, the pump indicates a fault. The Alarm LED and the 0(4) – 20 mA-LED illuminate.



The limit value was set to 2 mA, to avoid fluctuations in the error alarm current signal. The cable break function should be displayed before a complete interruption of the signal; the pump should stop.

Precondition for action:

- ✓ The pump assembly and installation have been completed successfully.
- ✓ Automatic operation was activated.

Perform the following working steps:

1. Install the line in accordance with section 9.2.2 Connection socket 2“ on page 24.
2. Press **0(4)–20mA**.
 - ▶ The 0(4) – 20 mA-LED illuminates.
3. Press **Start**.

✓ **The function cable break is activated.**

10.7.2 Level monitoring

You can connect an external level switch to the pump. The level switch monitors the filling level of a container with dosing medium. If the container is empty, the level switch sends a signal to the pump. The pump stops on the alarm and level LED illuminate.

Precondition for action:

- ✓ The assembly and installation of the pump and level switch have been completed successfully.

Perform the following working steps:

1. Install the level switch line in accordance with section 9.2.3 „Connection socket 3“ on page 24.
2. Press **Level**.
 - ▶ The level LED illuminates.
3. Press **Start**.

✓ **The function level monitoring is activated.**

10.8 The status of the pump



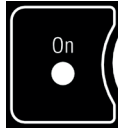
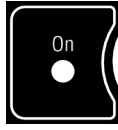
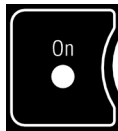
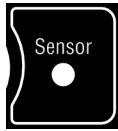



The current status of the pump can be read off from the operating panel.

Illuminated LED	Reason	Explanation
	The pump has started.	The pump was started and runs in the operating mode selected.
 (flashes)	The pump is in Start / Stop mode.	If the pump is set in the range 0 – 30 % the delivery capacity of the pump is altered via running and pause times. It no longer runs constantly.
 (Flashes quickly)	No external release any more.	The pump is stopped via the external clearance signal.
 (flashes)	The sensor LED flashes synchronously with every stroke.	The strokes can be read off from the sensor LED.



Tab. 27: The status of the pump

10.9 Error messages

Error messages and malfunctions can be read in the operating panel.

LEDs illuminated	Reason	Consequence	Solution
 (flashes)	System backpressure too high.	The motor protection is activated and the motor stops.	<ul style="list-style-type: none"> Reduce the back pressure. Then press Reset + Start to restart the pump.
 (flashes)	Motor too hot.	The motor protection is activated and the motor stops.	<ul style="list-style-type: none"> Allow the motor to cool. Then press Reset + Start to restart the pump.
 (Flashes quickly)	Insufficient mains voltage.	The motor protection is activated and the motor stops.	<ul style="list-style-type: none"> Set the correct mains voltage. Then press Reset + Start to restart the pump.
 + 	Dosing medium container empty.	Motor stops.	<ul style="list-style-type: none"> Re-establish the dosing medium supply. Then press Reset + Start to restart the pump.
 + 	Analogue signal lower than 2 mA.	Motor stops.	<ul style="list-style-type: none"> Re-establish the connection to the external controller. Then press Reset + Start to restart the pump.

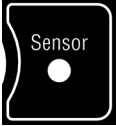
Tab. 28: Error messages

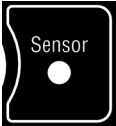
LEDs illuminated	Reason	Consequence	Solution
 <p>Reset</p> <p>+</p>  <p>Sensor</p>	<p>Damage to the gear.</p>	<p>Motor stops.</p>	<ul style="list-style-type: none"> ■ Replace the gears. ■ Consult the Lutz-Jesco GmbH service dept.
 <p>Reset</p> <p>+</p>  <p>Sensor</p>	<p>Proximity switch defective.</p>	<p>Motor stops.</p>	<ul style="list-style-type: none"> ■ Replace the proximity switch. ■ Consult the Lutz-Jesco GmbH service dept.

Tab. 28: Error messages

11 Operation



WARNING

Caustic burns or other burns through dosing media!

After connecting the mains supply, residual dosing media in the dosing head can spray out.

- ⇒ Wear the recommended personal protective equipment.
- ⇒ Make sure that the materials you are using are suitable for the dosing medium.
- ⇒ Make sure that the lubricants, adhesives, sealants, etc. that you use are suitable for the dosing medium.
- ⇒ Install a leakage drain.
- ⇒ Install pressure relief valves.



CAUTION!

Danger of automatic start up!

The dosing pump does not have an ON/OFF switch and may start to pump as soon as it is connected to the mains supply. This means that dosing medium can escape. Depending on the type and hazardousness of the dosing medium, this can result in injury.

- ⇒ Set the stroke length setting to 0 % before disconnecting it from the power supply.
- ⇒ Ensure that the dosing pump has been installed correctly before connecting it to the mains supply.



PLEASE NOTE

Overheating of the motor

If the fan cover is removed or is defective, insufficient motor cooling is provided.

- ⇒ Before starting the dosing pump, ensure that the motor fan cover is fitted and fully functional.

11.1 Commissioning the dosing pump



For initial commissioning, it is advisable to use water as the dosing medium to check that the system is leak-proof and that the dosing pump is functioning correctly. Check first whether undesirable reactions could occur between the actual dosing medium and the water.

At initial commissioning, it is advisable to prime the pump without backpressure. For this purpose, we recommend installing a relief valve on the discharge side of the dosing pump.

Precondition for action:

- ✓ The dosing pump has been assembled and installed in accordance with chapter 7 "Installing the Dosing Pump" on page 18, chapter 8 "Hydraulic installations" on page 19 and chapter 9 "Electrical installation" on page 22.
- ✓ All the mechanical fastenings have been inspected to ensure adequate load-bearing capacity.
- ✓ The dosing head screws have been tightened with the correct torque (see chapter 12.3 "Tightening the dosing head nuts" on page 34).
- ✓ All the hydraulic sections have been inspected to ensure they are adequately leak-proof and that the through flow direction is correct.
- ✓ The drive motor and all associated additional equipment is checked for proper connection.
- ✓ Personnel have read all the operating instructions and understood them completely.

Resources required:

- ✘ Gear oil of the viscosity class ISO-VG100 (SAE 40). The filling capacity is about 3 l.

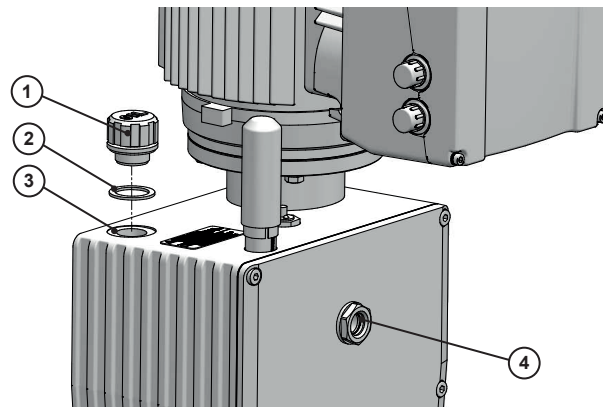

Fig. 14: Dosing pump oil inlet

Perform the following working steps:

1. Unscrew the closing screw (1) from the oil inlet (3) and remove the seal (2).
 2. Fill oil in the oil inlet. Check the oil level in the oil level glass (4) at the same time. The oil level should reach to c. the middle of the oil level glass.
 3. Place the washer seal (2) onto the oil inlet (3) and tighten up the closing screw.
 4. If present, open the pressure and suction side shut-off valves.
 5. Connect the dosing pump to the power supply.
- ✓ **The dosing pump is commissioned.**

11.2 Adjusting the delivery rate

The stroke length of the pump is always the same. The delivery rate is set via the vertical position of the slide valve. The maximum delivery rate has been set if the slide valve is standing in the highest position. The setting can be read off from the scale of the delivery rate adjustment unit.

The compressibility of the hydraulic oil and the process fluid restricts the delivery rate. The pump is designed so that the maximum nominal pressure is reached upon nominal supply.

Depending on the actual operating conditions, it can be necessary to perform further settings on-site. If the delivery pressure is lower than the specified maximum, or the process fluid exhibits a smaller compressibility, the characteristic curve moves upwards. If the compressibility is higher, the characteristic curve is displaced downwards. Whatever happens, the linearity of the characteristic curve is not affected (see Fig. 15: Delivery characteristic curves“ on page 31). The delivery rate is adjusted using the manual stroke adjustment unit. The calibration of the delivery rate setting is performed as follows.

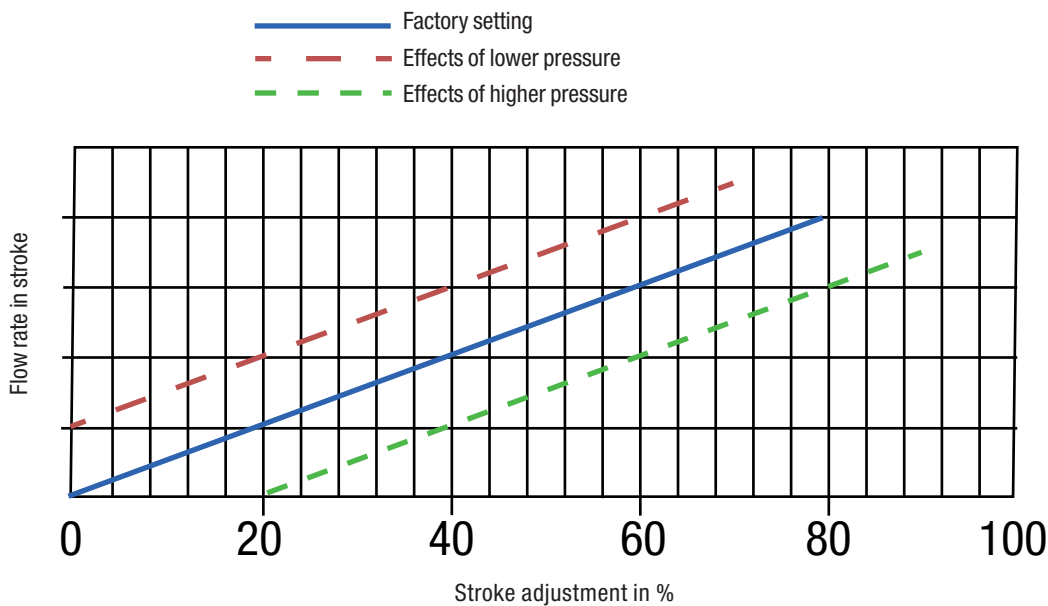

Fig. 15: Delivery characteristic curves

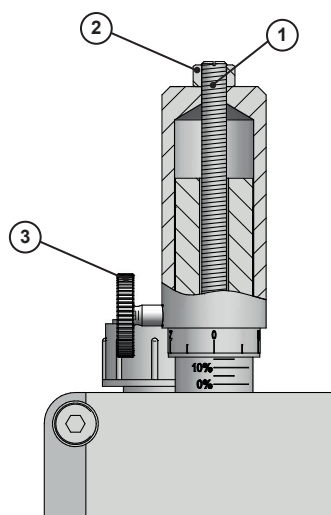

Fig. 16: Adjusting the delivery rate

Perform the following working steps:

1. If the pump supplies at normal system pressure, turn in the manual delivery rate adjustment unit until the supply stream ends and the pump stops.
2. Remove the protective cap of the manual stroke adjustment unit.
3. Hold the threaded rod (1) in position with a screwdriver.
4. Loosen the upper nut (2) and the curled thumb screw (3).

5. Continue to hold the threaded rod (1) tight and turn the stroke adjustment unit to zero percent.
6. Retighten the nut (2).
7. Place on the protective cap.

✓ **Calibration of the delivery rate setting completed.**

11.3 Decommissioning the dosing pump

Perform the following working steps:

1. Stop the dosing pump by turning the delivery rate setting to 0 %.
2. Disconnect the dosing pump from the power supply.
3. Disconnect all electrical connections.
4. Depressurize all the hydraulic parts in the system.
5. Unplug all the hydraulic connections on the dosing pump.
6. Empty the dosing head.
7. Remove any residual dosing medium from the dosing head by flushing the system with a washing agent. Ensure that the washing agent is compatible with the dosing medium.

✓ **Dosing pump is decommissioned.**

11.4 Shutting down in an emergency

- In an emergency, you must immediately disconnect the dosing pump from the mains supply or activate the Emergency Stop switch installed

in the system.

- Depending on the type of incident, you must depressurized the hydraulic connections or locked to prevent dosing medium from escaping.
- You must follow the safety data sheet of the dosing medium.

11.5 Storage

Storing the dosing pump correctly extends its service life. You should avoid negative influences such as extreme temperatures, high humidity, dust, chemicals, etc.

Ensure ideal storage conditions where possible:

- The storage place must be cold, dry, dust-free and moderately ventilated
- Temperatures between + 2 °C and + 40 °C,
- Relative air humidity must not exceed 90 %

11.6 Transportation



PLEASE NOTE

Machine damage caused by leaking oil

The oil inlet at the dosing pump cannot be closed completely tightly. Oil may leak if the device is not transported in an upright position. This might cause damage to the control unit or the motor.

⇒ Drain the oil completely through the oil outlet before you transport the dosing pump.

Perform the following working steps:

1. Clean the device thoroughly. Any dangerous dosing media must be additionally neutralised and decontaminated.
2. Disassemble all accessories.
3. Close all openings, so that no foreign objects can get into the system.
4. The dosing pump must be suitably packed, preferably in the original packing, for transportation.
5. If the device is sent back to the manufacturer, please follow chapters 17 „Declaration of no objection“ on page 43 and 18 „Warranty claim“ on page 44.

✓ **The device can now be shipped.**

11.7 Disposal of old equipment

- Clean the device thoroughly. Any dangerous dosing media must be additionally neutralised and decontaminated.
- Dispose of dosing medium residue in the correct fashion.
- Dispose the dosing pump in accordance with applicable local laws and regulations. The device does not belong to household waste!
- As the disposal regulations may differ from country to country in the European Union, please consult your supplier if necessary.

12 Maintenance

Lutz-Jesco GmbH dosing pumps are produced to the highest of quality standards with a long service life. Nevertheless, some of their parts are subject to wear due to operation (e.g. diaphragms, valve seats, valve balls). This means that regular visual inspections and maintenance are necessary to ensure a long operating life and to avoid interruption of service.

DANGER!

Mortal danger from electric shock!

Live parts can inflict fatal injuries.

- ⇒ Before carrying out any maintenance work, always disconnect the dosing pump from the power supply.
- ⇒ Secure the dosing pump from accidental power-up.
- ⇒ The protective conductor (earth) may only be removed during the last step.
- ⇒ After maintenance work, all earthing measures must be restored.

WARNING

Caustic burns or other burns through dosing media!

While working on the dosing head, valves and connections, you may come into contact with dosing media.

- ⇒ Wear the recommended personal protective equipment.
- ⇒ Rinse the dosing pump with a medium (e.g. water) which does not pose any risk.
- ⇒ Release pressure in hydraulic parts.
- ⇒ Before connecting the mains supply, connect the dosing lines.
- ⇒ Check that all the screw connections have been tightened correctly and are leak-proof.

CAUTION!

Danger of personal injury and material damage!

The dosing pump can generate a pressure that is many times the rated one. The dosing medium can escape in the case of material failure or wear on the dosing head, the connection pipe or the seals that are used.

- ⇒ Carry out maintenance work at the recommended intervals.

The following safety instructions apply exclusively for explosive risk areas:

DANGER!

Danger to life through explosions!

Sparks may be formed during repair work by contact between tools or components.

- ⇒ Only use tools which are suitable for use in explosive risk zones 1 and 2.

DANGER!

Danger to life through explosions!

Friction in parts of the dosing pump or system which are made of non-conducting plastic, can cause electrostatic charging.

- ⇒ Clean plastic parts carefully with a damp cloth.

DANGER!

Danger to life through explosions!

The dosing pump can run hot if there is not enough oil. This could result in explosions occurring in explosive risk areas.

- ⇒ Regularly check the oil level.
- ⇒ If oil is leaking, the leak must be immediately fixed and the dosing pump taken out of operation.

12.1 Maintenance intervals

This table gives you an overview of maintenance work and the intervals at which you must carry it out. The next few sections contain instructions for carrying out this work.

Maintenance work	Frequency
Check the oil level in the oil level glass	Regularly
Change the oil	<ul style="list-style-type: none"> ■ Change the first filling after 5,000 operating hours or 1 year, whichever comes first. ■ A further oil change after 10,000 operating hours or 2 years, whichever comes first.
Check that piping is seated firmly	Regularly
Check that suction and pressure valves are seated firmly	Regularly

Tab. 29: Maintenance information and maintenance intervals

Maintenance work	Frequency
Clean suction and pressure valves	Regularly
Check that electrical connections are not damaged	Regularly
Tighten up dosing head bolts	<ul style="list-style-type: none"> ■ Regularly ■ Before initial commissioning ■ After each diaphragm change
Check diaphragm for leakage due to rupture	Regularly (as long as no leak monitoring system is installed)
Check the dosing pump for unusual noises during operation, unusual temperatures or smells	Regularly
Replace parts that are subject to wear (diaphragms, valves, seals, etc.)	When unacceptable levels of wear are detected
Rinse out and clean the dosing pump	<ul style="list-style-type: none"> ■ Before taking out of service for a long period of time ■ After feeding aggressive, sticky, crystallising or contaminated liquids
Checking the electric servomotor	Regularly

Tab. 29: Maintenance information and maintenance intervals

12.2 Change the oil

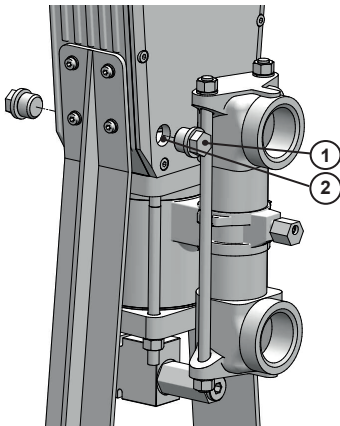

Fig. 17: Draining oil on the dosing pump

Resources required:

- ✂ Oil collecting pan
- ✂ Low viscosity oil of the viscosity class ISO-VG100 (SAE 40)

Perform the following working steps:

1. Unscrew the closing screw (1) from the oil drain (2).
2. Completely drain the oil from the housing into oil collection container.
3. Place the washer seal onto the oil outlet and tighten up the closing screw.

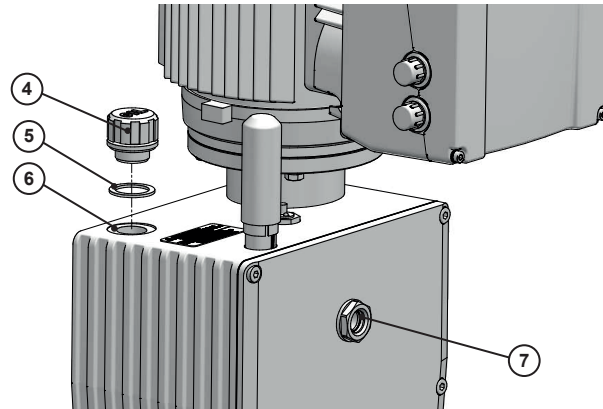

Fig. 18: Dosing pump oil inlet

4. Unscrew the closing screw (4) from the oil inlet (6) and remove the seal (5).
5. Fill oil in the oil inlet. Check the oil level in the oil level glass (7) at the same time. The oil level should reach to c. the middle of the oil level glass.
6. Place the washer seal (5) onto the oil inlet (6) and tighten up the closing screw (4).

✓ **Oil change complete.**

12.3 Tightening the dosing head nuts

Comply with the following rules when tightening the dosing head nuts:

- Use a torque wrench.
- Moisten the thread of the nuts lightly with oil.
- Always tighten the nuts crosswise.
- Tighten the nuts in four steps: with 27 Nm, 34 Nm, 40 Nm and the last step with 48 Nm.

12.4 Diaphragm replacement

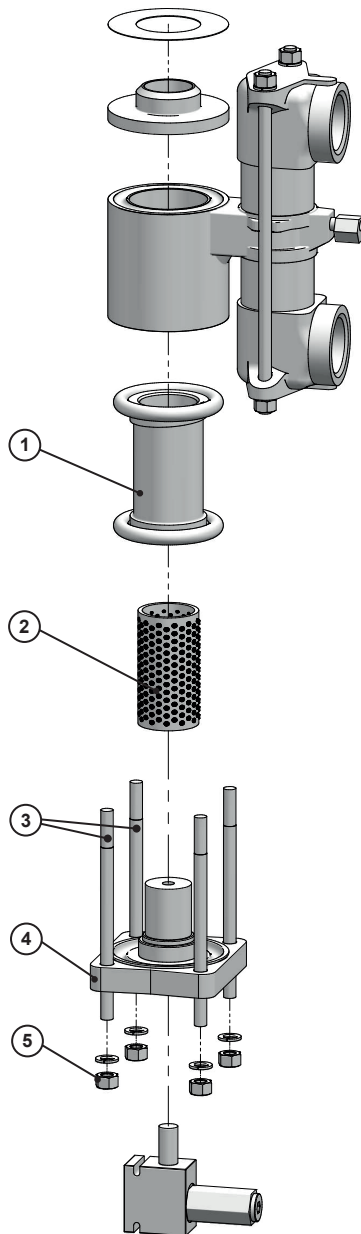

Fig. 19: Diaphragm change 1" dosing head

Precondition for action:

- ✓ The pump has been deactivated.
- ✘ Oil collecting pan

Perform the following working steps:

1. Switch off the pump
2. Close the valves of the inflow and outflow pipes.
3. Now drain the oil from the pump.
4. Remove the valve bolts (3) and the valves and dosing head connections.
5. Remove the nut of the dosing head bolt (5).

6. Press the entire dosing head module downwards and away from the pump housing in order to remove it. If the dosing head can only be moved with difficulty or not at all, turn the motor by hand (on the fan wheel of the electric drive) to lift the piston and thereby to create sufficient space.
7. Remove the cylinder end cap (4) of the dosing head.



PLEASE NOTE

Damage to the hose diaphragm

Sharp objects can damage the diaphragm during installation and disassembly.

⇒ Do not use any sharp objects such as a screwdrivers.

8. Press the diaphragm support (2) out of the hose diaphragm (1).
9. Clean all parts before re-assembly.



A slight oil film on the diaphragm and cylinder facilitates installation of the hose diaphragm. Rotate the hose diaphragm in such a way that the high shoulder is directly adjacent to the opening of the dosing head. The position can be read off from the material code on the upper side of the hose diaphragm.

10. The new hose diaphragm can be installed folded in the lower flange and pressed through the drill-hole of the dosing head using a blunt rod.
 11. Re-assemble all the parts in the reverse order.
- ✓ **Diaphragm change finished.**

12.5 Changing the ball valves

Inspect the valve ball and valve seats and replace the O-rings at the same time as the hose diaphragm.

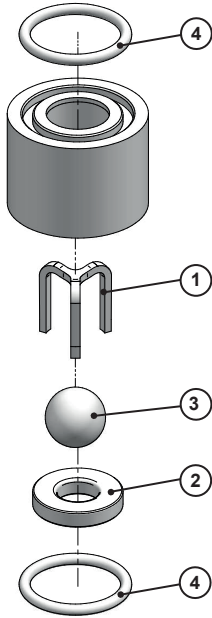

Fig. 20: Changing the ball valves

Perform the following working steps:

1. To dismantle the valve into its constituent parts, press against the ball guide (1) with a blunt rod and press it out of the valve together with the valve seat (2) and the valve ball (3).
 - ▶ No unevenness may be visible on the surface of the valve seat. Replace the valve seat given any unevenness.



If the surface of the valve seat has been damaged by erosion or corrosion, the valve seat can be turned to provide a new sealing surface.

2. Replace both O-rings (4) of the valve.
3. Return the valve between the “ear” of the dosing head and the dosing head connections. The arrows on the valves must point upwards.
4. Position the valves in the centre and retighten the valve bolts.
5. If no further maintenance work is required on the pump, fill the pump to the mark with oil before starting it.

✓ **Ball valves changed.**

12.6 Changing the poppet valves

Inspect the valve components and replace the O-rings at the same time as the hose diaphragm.

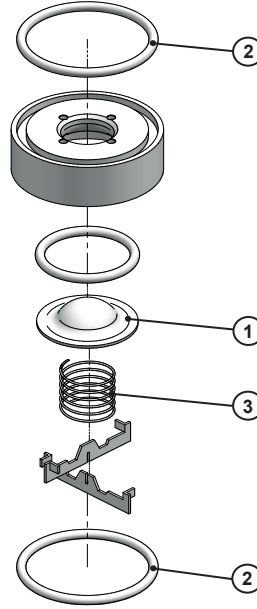

Fig. 21: Poppet valve

Perform the following working steps:

1. To dismantle the valve, press carefully on the plate (1) without deforming it.
2. Inspect the individual components for erosion and corrosion. Also check the spring (3).
3. Replace worn or corroded components.
4. Replace both O-rings (2) of the valve.
5. Return the valve between the “ear” of the dosing head and the dosing head connections. The arrows on the valves must point upwards.
6. Position the valves in the centre and retighten the valve bolts.
7. If no further maintenance work is required on the pump, refill the pump with oil before starting it.

✓ **Poppet valves replaced.**

13 Troubleshooting

See below for information about how to rectify faults on the device or the system. If you cannot eliminate the fault, please consult with the manufacturer on further measures or return the dosing pump for repair.

13.1 Type of fault

13.1.1 Dosing pump not delivering or output too low

Possible cause	Remedy
Wrong type of dosing pump selected	→ Check the dosing pump's technical data and if necessary select a type with a higher delivery capacity.
Valve leaking or blocked	→ Clean the valve and vent the dosing pump. → Tighten the screw connections.
Valve installed incorrectly	→ Reassemble the valve. Ensure that the valve balls are located above the valve seats.
Valve damaged (e.g. valve balls)	→ Remove the damaged parts or install a new valve.
Suction line is leaking	→ Seal the leak locations or replace the parts.
Suction line is blocked (e.g. screen in foot valve)	→ Clean the suction line.
Shut-off valves closed	→ Open the shut-off valves. Inspect the dosing pump for possible damage.
Suction head too high	→ Set the dosing pump to feed or reduce the suction head. → Install a priming aid.
Viscosity too high	→ Possibly reduce the concentration of the dosing medium or increase the temperature. → Install spring-loaded valves. → Increase the pipe diameter.
Current supply interrupted	→ Reconnect the current supply
The drive motor's electrical data does not match that of the mains supply	→ Check the electrical installation.
System backpressure too high (measured at discharge connection of dosing pump)	→ Clean blocked injection nozzle. → Install pulsation dampeners to reduce pressure peaks if pipes are too long. → Check function of safety valves.

Tab. 30: Type of fault: Dosing pump not delivering or output too low

13.1.2 Dosing pump does not prime

Possible cause	Remedy
Valve leaking or blocked	→ Clean the valve and vent the dosing pump. → Tighten the screw connections.
Valve installed incorrectly	→ Reassemble the valve. Ensure that the valve balls are located above the valve seats.
Valve damaged (e.g. valve balls)	→ Remove the damaged parts or install a new valve.
Suction line is leaking	→ Seal the leak locations or replace the parts.
Suction line is blocked (e.g. screen in foot valve)	→ Clean the suction line.
Shut-off valves closed	→ Open the shut-off valves. Inspect the dosing pump for possible damage.
Suction head too high	→ Set the dosing pump to feed or reduce the suction head. → Install a priming aid.
Viscosity too high	→ Possibly reduce the concentration of the dosing medium or increase the temperature. → Install spring-loaded valves. → Increase the pipe diameter.
Current supply interrupted	→ Reconnect the current supply
Dry the valves	→ Dampen the dosing head and the valves → Vent the dosing head.
Air in the suction line with simultaneous pressure on the pressure valve	→ Vent the dosing head or the lines.

Tab. 31: Type of fault: Dosing pump does not prime

13.1.3 Delivery rate varies

Possible cause	Remedy
Valve leaking or blocked	<ul style="list-style-type: none"> ➔ Clean the valve and vent the dosing pump. ➔ Tighten the screw connections.
Valve damaged (e.g. valve balls)	➔ Remove the damaged parts or install a new valve.
Suction line is leaking	➔ Seal the leak locations or replace the parts.
Suction line is blocked (e.g. screen in foot valve)	➔ Clean the suction line.
Viscosity too high	<ul style="list-style-type: none"> ➔ Possibly reduce the concentration of the dosing medium or increase the temperature. ➔ Install spring-loaded valves. ➔ Increase the pipe diameter.
The drive motor's electrical data does not match that of the mains supply	➔ Check the electrical installation.
Suction side pressure too high (pump siphoning)	➔ Install a back-pressure valve in the pressure line.
Pressure peaks due to acceleration with long suction lines	➔ Install a suction pressure regulator.
Imprecise dosing due to changeable positive and negative suction heads.	➔ Install a suction pressure regulator.
System backpressure too high (measured at discharge connection of dosing pump)	<ul style="list-style-type: none"> ➔ Clean blocked injection nozzle. ➔ Install pulsation dampeners to reduce pressure peaks if pipes are too long. ➔ Check the safety valves.

Tab. 32: Type of fault: Delivery rate varies

13.1.4 No stroke movement observed

Possible cause	Remedy
Dosing pump set to zero stroke.	➔ Set the stroke length adjusting knob correctly.
Current supply interrupted	➔ Reconnect the current supply
The drive motor's electrical data does not match that of the mains supply	➔ Check the electrical installation.

Tab. 33: Type of fault: No stroke movement observed

13.1.5 Dosing pump delivery rate too high

Possible cause	Remedy
Suction side pressure too high (pump siphoning)	➔ Install a back-pressure valve in the pressure line.
Pressure peaks due to acceleration with long suction lines	➔ Install a suction pressure regulator.

Tab. 34: Type of fault: Dosing pump delivery rate too high

13.1.6 Diaphragm is torn or tears too often

Possible cause	Remedy
Too little or no back pressure	➔ The back pressure must be increased so that the hose diaphragm is able to return to its original position.
Hose diaphragm fitted incorrectly.	➔ The hose diaphragm must be installed in the pump in such a way that the high shoulder is directly adjacent to the opening of the dosing head. This position can be read off from a material code letter on the upper side of the hose diaphragm.
Shut-off valves closed	➔ Open the shut-off valves. Inspect the dosing pump for possible damage.
Pressure peaks due to acceleration with long suction lines	➔ Install a suction pressure regulator.
The materials are not suitable for the dosing medium being used	➔ Check the resistance of the materials.
Diaphragm not screwed up to the end stop on the diaphragm rod	➔ Screw a new diaphragm up to the end stop.
System backpressure too high (measured at discharge connection of dosing pump)	<ul style="list-style-type: none"> ➔ Clean blocked injection nozzle. ➔ Install pulsation dampeners to reduce pressure peaks if pipes are too long. ➔ Check function of safety valves.
Media sediment in dosing head	➔ Clean the dosing head.

Tab. 35: Type of fault: Diaphragm is torn or tears too often

13.1.7 Loud noises on the dosing pump

Possible cause	Remedy
Roller bearing defective	→ Contact the manufacturer.

Tab. 36: Type of fault: Loud noises on the dosing pump

13.1.8 The drive is overloaded

Possible cause	Remedy
Shut-off valves closed	→ Open the shut-off valves. Inspect the dosing pump for possible damage.
The drive motor's electrical data does not match that of the mains supply	→ Check the electrical installation.
Pressure peaks due to acceleration with long suction lines	→ Install a suction pressure regulator.
System backpressure too high (measured at discharge connection of dosing pump)	→ Clean blocked injection nozzle. → Install pulsation dampeners to reduce pressure peaks if pipes are too long. → Check function of safety valves.

Tab. 37: Type of fault: The drive is overloaded

13.1.9 Motor hums and does not start.

Possible cause	Remedy
The drive motor's electrical data does not match that of the mains supply	→ Check the electrical installation.
System backpressure too high (measured at discharge connection of dosing pump)	→ Clean blocked injection nozzle. → Install pulsation dampeners to reduce pressure peaks if pipes are too long. → Check function of safety valves.
No or insufficient oil in the gearbox	→ Fill up the gearbox oil.

Tab. 38: Type of fault: Motor hums and does not start.

14 Spare parts

Required set for a complete service:

- One diaphragm spare parts kit including hose diaphragm and one set of O-rings

Further spare parts

- Dosing valves
- Safety valves

15 Delivery characteristic curves

This Chapter is intended to give you an idea of the delivery capacity that the dosing pump can achieve at specific back pressures. These delivery capacities were determined on the manufacturer's test stands. They apply at 20 °C (68 °F) for water, at 100 % stroke frequency. The delivery capacity depends on the medium (density and viscosity) and temperature. Since these conditions vary at every installation location, you should calibrate the dosing pump.

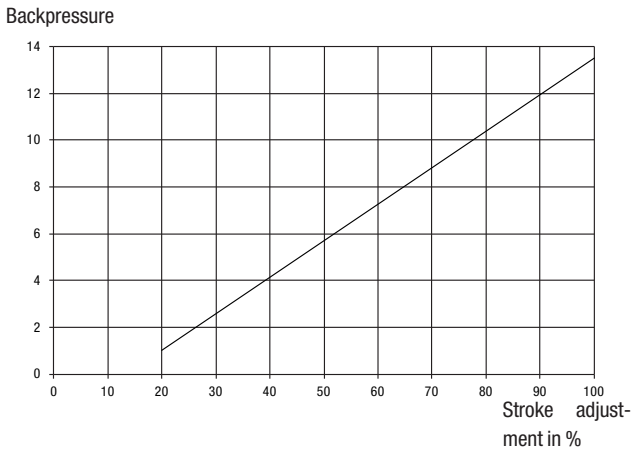

Fig. 22: Delivery characteristic curve MEMDOS KMS LB/LA 14

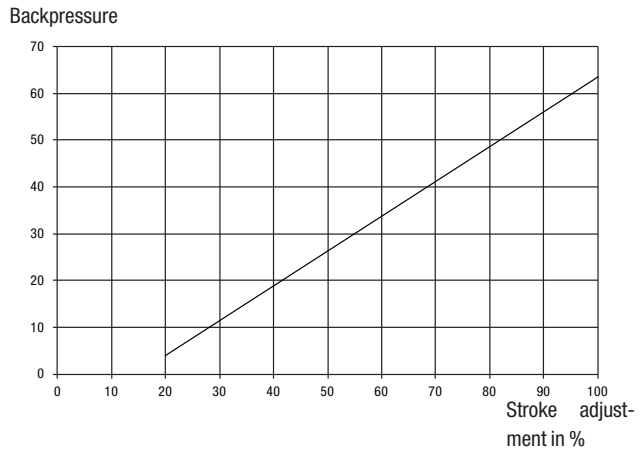

Fig. 25: Delivery characteristic curve MEMDOS KMS LB/LA 60

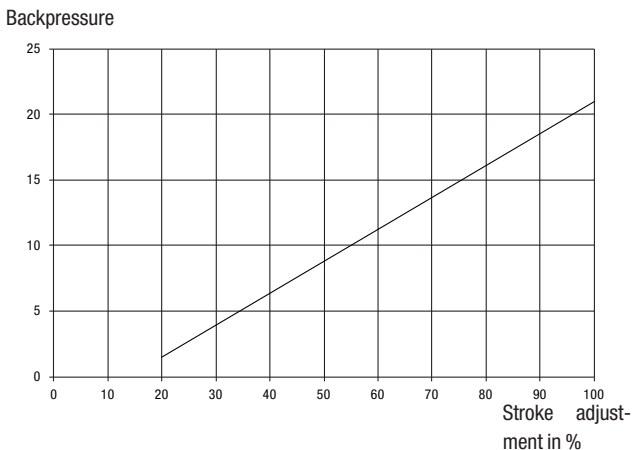

Fig. 23: Delivery characteristic curve MEMDOS KMS LB/LA 20

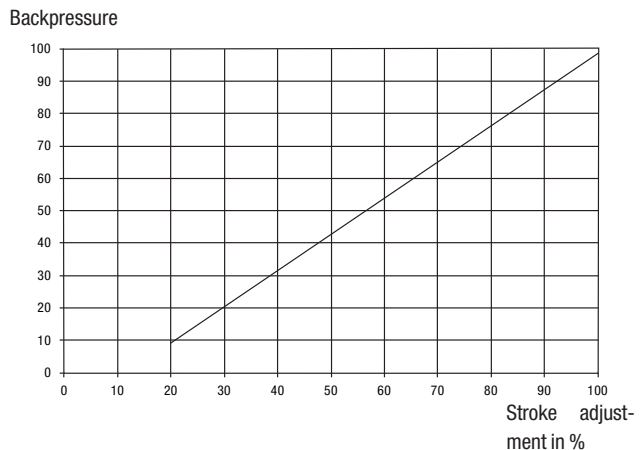

Fig. 26: Delivery characteristic curve MEMDOS KMS LB/LA 100

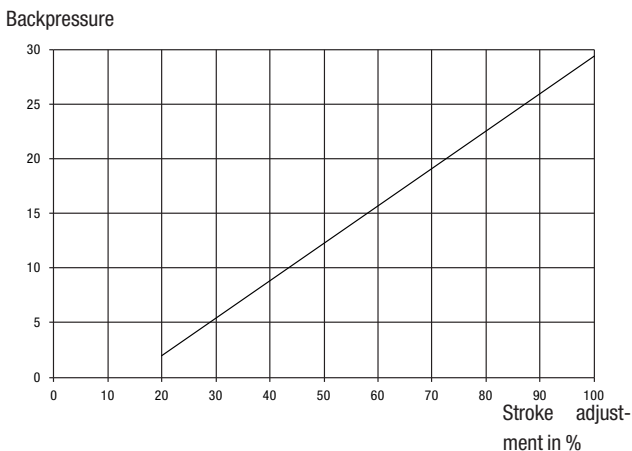

Fig. 24: Delivery characteristic curve MEMDOS KMS LB/LA 30

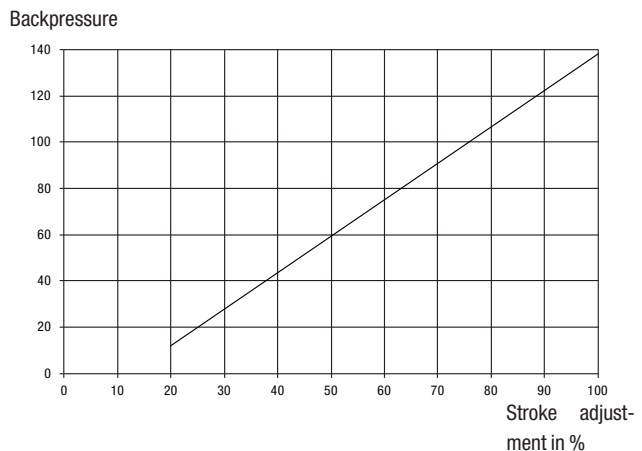

Fig. 27: Delivery characteristic curve MEMDOS KMS LB/LA 140

Backpressure

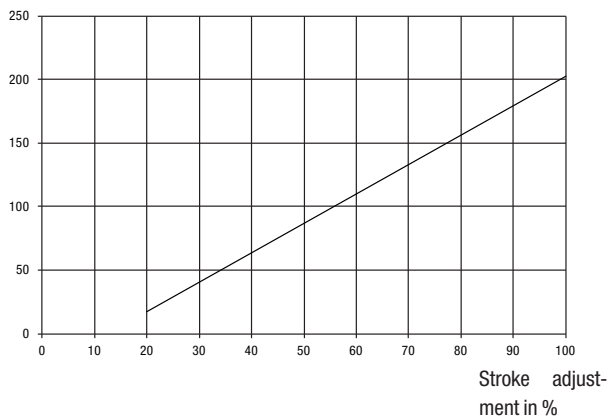

Fig. 28: Delivery characteristic curve MEMDOS KMS LB/LA 200

Backpressure

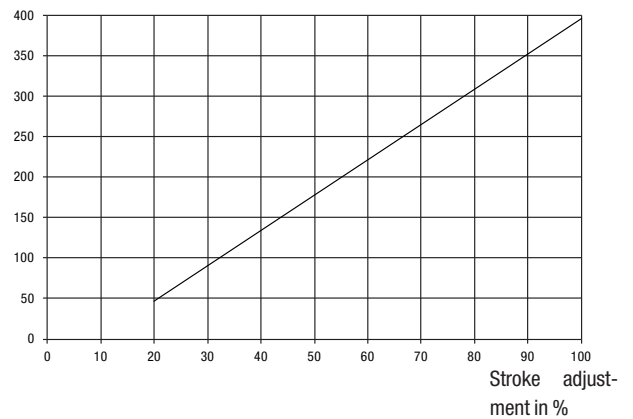

Fig. 31: Delivery characteristic curve MEMDOS KMS LB/LA 400

Backpressure

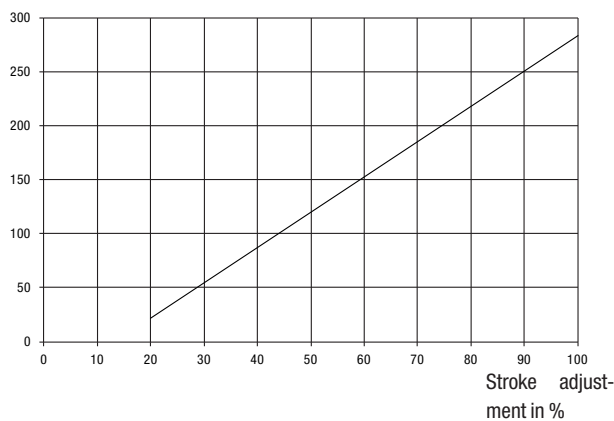

Fig. 29: Delivery characteristic curve MEMDOS KMS LB/LA 285

Backpressure

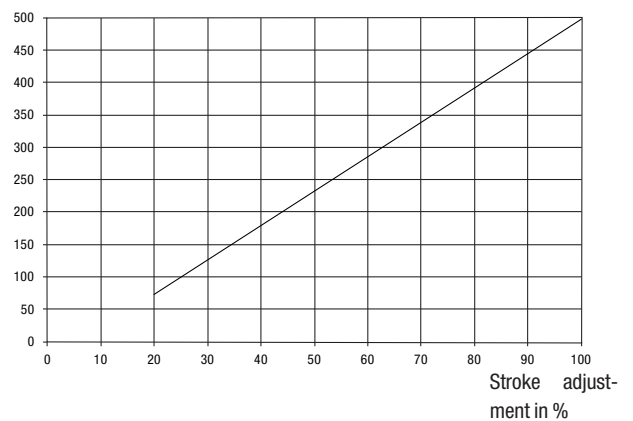

Fig. 32: Delivery characteristic curve MEMDOS KMS LB/LA 500

Backpressure

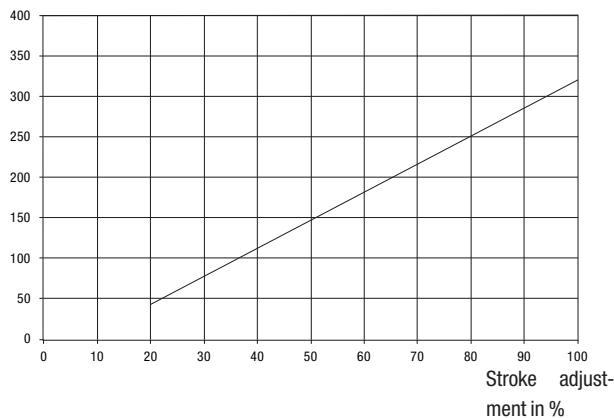

Fig. 30: Delivery characteristic curve MEMDOS KMS LB/LA 320

Backpressure

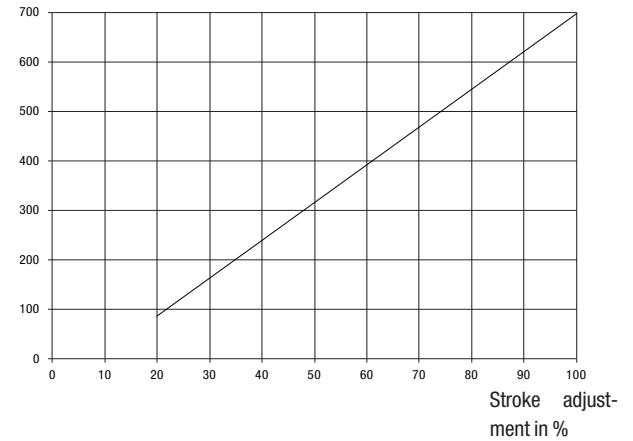

Fig. 33: Delivery characteristic curve MEMDOS KMS LB/LA 700

16 EU Declaration of Conformity



(DE) EU-Konformitätserklärung

Hiermit erklären wir, dass das nachfolgend bezeichnete Gerät aufgrund seiner Konzipierung und Bauart sowie in der von uns in Verkehr gebrachten Ausführung den einschlägigen grundlegenden Sicherheits- und Gesundheitsanforderungen der aufgeführten EG-Richtlinien entspricht. Bei einer nicht mit uns abgestimmten Änderung am Gerät verliert diese Erklärung ihre Gültigkeit.

(EN) EU Declaration of Conformity

We hereby certify that the device described in the following complies with the relevant fundamental safety and sanitary requirements and the listed EC regulations due to the concept and design of the version sold by us.

If the device is modified without our consent, this declaration loses its validity.

(FR) Déclaration de conformité UE

Nous déclarons sous notre propre responsabilité que le produit ci-dessous mentionné répond aux exigences essentielles de sécurité et de santé des directives CE énumérées aussi bien sur le plan de sa conception et de son type de construction que du modèle que nous avons mis en circulation.

Cette déclaration perdra sa validité en cas d'une modification effectuée sur le produit sans notre accord explicite.

(ES) Declaración de conformidad UE

Por la presente declaramos que, dados la concepción y los aspectos constructivos del modelo puesto por nosotros en circulación, el aparato mencionado a continuación cumple con los requisitos sanitarios y de seguridad vigentes de las directivas de la U.E. citadas a continuación.

Esta declaración será invalidada por cambios en el aparato realizados sin nuestro consentimiento.

(NL) EU-overeenstemmingsverklaring

Ondergetekende Lutz-Jesco GmbH, bevestigt, dat het volgende genoemde apparaat in de door ons in de handel gebrachte uitvoering voldoet aan de eis van, en in overeenstemming is met de EU-richtlijnen, de EU-veiligheidsstandaard en de voor het product specifieke standaard. Bij een niet met ons afgestemde verandering aan het apparaat verliest deze verklaring haar geldigheid.

(PT) Declaração de conformidade UE

Declaramos pelo presente documento que o equipamento a seguir descrito, devido à sua concepção e ao tipo de construção daí resultante, bem como a versão por nós lançada no mercado, cumpre as exigências básicas aplicáveis de segurança e de saúde das directivas CE indicadas.

A presente declaração perde a sua validade em caso de alteração ao equipamento não autorizada por nós.

Bezeichnung des Gerätes:	Kolben-Membrandosierpumpe
Description of the unit:	Piston-diaphragm dosing pump
Désignation du matériel:	Pompe doseuse à piston et membrane
Descripción de la mercancía:	Bomba dosificadora de pistón y membrana
Omschrijving van het apparaat:	Zuigermembraan-doseerpomp
Designação do aparelho:	Bomba dosadora de pistões e diafragmas
Typ:	MEMDOS KMS LB
Type:	MEMDOS KMS LA
EU-Richtlinien:	2014/30/EU, 2014/35/EU
EC directives:	Die Schutzziele der Niederspannungsrichtlinie 2014/35/EU wurden gemäß Anhang I, Nr. 1.5.1 der Maschinenrichtlinie 2006/42/EG eingehalten. The protective aims of the Low Voltage Directive 2014/35/EU were adhered to in accordance with Annex I, No. 1.5.1 of the Machinery Directive 2006/42/EC.
Harmonisierte Normen:	EN 809:2012-10
Harmonized standards:	DIN EN ISO 12100:2011-03
Dokumentationsbevollmächtigter:	Lutz-Jesco GmbH
Authorized person for documentation:	

Heinz Lutz
Geschäftsführer / Chief Executive Officer
Lutz-Jesco GmbH
Wedemark, 15.11.2019

Lutz-Jesco GmbH
Am Bostelberge 19
30900 Wedemark
Germany

17 Declaration of no objection

Please copy the declaration, stick it to the outside of the packaging and return it with the device.

Declaration of no objection

Please fill out a separate form for each appliance!

We forward the following device for repairs:

Device and device type: Part-no.:

Order No.: Date of delivery:

Reason for repair:

Dosing medium

Description: Irritating: Yes No

Properties: Corrosive: Yes No

We hereby certify, that the product has been cleaned thoroughly inside and outside before returning, that it is free from hazardous material (i.e. chemical, biological, toxic, flammable, and radioactive material) and that the lubricant has been drained.

If the manufacturer finds it necessary to carry out further cleaning work, we accept the charge will be made to us.

We assure that the aforementioned information is correct and complete and that the unit is dispatched according to the legal requirements.

Company / address: Phone:

..... Fax:

..... Email:

Customer No.: Contact person:

Date, Signature:

18 Warranty claim

Warranty claim

Please copy and send it back with the unit!

If the device breaks down within the period of warranty, please return it in a cleaned condition with the complete warranty claim.

Sender

Company: Phone: Date:

Address:

Contact person:

Manufacturer order no.: Date of delivery:.....

Device type: Serial number:

Nominal capacity / nominal pressure:

Description of fault:.....

.....
.....
.....
.....
.....
.....
.....
.....
.....
.....

Service conditions of the device

Point of use / system designation:.....

.....

.....

Accessories used (suction line etc.):.....

.....

.....

.....

Commissioning (date):

Duty period (approx. operating hours):

Please describe the specific installation and enclose a simple drawing or picture of the chemical feed system, showing materials of construction, diameters, lengths and heights of suction and discharge lines.

19 Index

A

Accessories	20
Approved media temperature	13
Automatic operation	26

B

Back-pressure valve	20
---------------------------	----

C

Cable break	27
Commissioning the dosing pump	30
Control box	
Error messages	28

D

Declaration of no objection	43
Decommissioning the dosing pump	31
Delivery characteristic curves	40
Design of the system	19
Diaphragms	
Replace	35
Dimensioned drawings	16
Dimensions	16
Disposal of old equipment	32
Dosing media	
Approved media temperature	13
Prohibited dosing media	8

E

Electrical installation	22
-------------------------------	----

F

Foreseeable misuse	8
Function description	11

G

General warnings	5
------------------------	---

H

Handling instructions	
Marking	4
Hazards due to non-compliance with the safety instructions	6
Hydraulic accessories	20
Hydraulic installations	19

I

Injection nozzle	20
Installation	
electrical	22
hydraulic	19
Installing the Dosing Pump	18
Intended purpose	8
Intended use	8

L

Level monitoring	27
------------------------	----

M

Maintenance	33
Maintenance intervals	33
Manual operation	26

N

Notes for the Reader	4
----------------------------	---

O

Operating conditions and limits	13
Operating modes	26
Operation	25

P

Personnel qualification	6
Pressure-relief valve	20
Priming aid	21
Product description	10
Product warranty	8
Prohibited dosing media	8
Pulsation dampener	21

R

Rating plate	12
--------------------	----

S

Safety	5
Scope of delivery	10
Set up information	18
Shut-down	31
Shutting down in an emergency	31
Signal words	
Explanation	4
Spare parts	39
Specialist staff	6
Storage	32
Structure of the dosing pump	10
Suction pressure regulator	21
Suspensions	21
System piping	20

T

Technical data	13
Temperatures	
Approved ambient temperature	13
Approved media temperature	13
Tighten up dosing head bolts	34
Transportation	32
Troubleshooting	37

W

Wall bracket	18
--------------------	----

Warnings	
General warnings	5
Marking	4
Warning sign	
Explanation	4
Warranty claim	44
Working in a safety-conscious manner	6

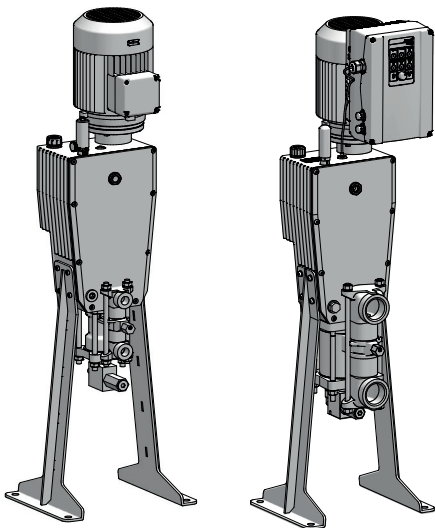

Lutz-Jesco GmbH

Am Bostelberge 19
D-30900 Wedemark

Phone: +49 5130 5802-0
info@lutz-jesco.com
www.lutz-jesco.com

Operating instructions
MEMDOS KMS LB/LA