

Solenoid-Diaphragm Dosing Pump

MAGDOS LP

Operating Instructions



Read the Operating Instructions!

The user is responsible for installation and operation related mistakes!

Contents

1	Notes to the Reader	4	Explanation of menu navigation	31
	General non-discrimination	4	Explanation of the menu icons	31
	Explanations of signal words	4	Menu settings at initial commissioning	32
	Explanations of warning signs	4	Main menu	32
	Identification of warnings	4	System setup	32
	Identification of instructions for action	5	Information about the dosing pump	37
			Messages of the control unit	37
2	Safety	6	11 Operation	38
	General warnings	6	Commissioning the dosing pump	38
	Hazards due to non-compliance with the safety instructions	7	Operating modes	40
	Safe operation	7	External On/Off via Release input	47
	Personal protective equipment	7	Decommissioning the dosing pump	47
	Personnel qualification	7	Shutting down in an emergency	48
3	Appropriate and intended use	8	Storage	48
	Notes on product warranty	8	Transportation	48
	Intended purpose	8	Disposal of old units	48
	Device revision	8	12 Maintenance	49
	Principles	8	Maintenance intervals	49
	Prohibited dosing media	8	Tighten dosing head bolts	50
	Foreseeable misuse	9	Change the diaphragm	50
4	Product Description	10	Clean suction and discharge valves	50
	Properties	10	13 Troubleshooting	51
	Scope of delivery	10	Type of fault	51
	Structure of the dosing pump	10	List of control unit messages	53
	Function description	11	14 Spare parts	54
	Nameplate	11	Diaphragm spare parts kits	54
5	Technical Data	12	Dosing head spare parts kits including valves	54
	Delivery capacity data	12	15 Delivery characteristic curves	55
	Operating conditions and limits	12	16 Menu structure of the Control Unit	56
	Electrical data	13	Program start	56
	Other data	13	System setup	56
6	Dimensions	14	Main menu	59
	MAGDOS LP with dosing head made of PVC, PP or PVDF	14	17 Appendix	64
	MAGDOS LP with dosing head made of stainless steel (1.4571) ...	14	Addresses of MODBUS TCP/IP protocol (MAGDOS LP-Net)	64
7	Installing the Dosing Pump	15	Default settings	66
	Set up information	15	18 EC Declaration of Conformity	68
	Installation examples	15	19 Declaration of harmlessness	70
8	Hydraulic installation	16	20 Warranty application	72
	Dimensioning of the system	16	21 Index	73
	System piping	17		
	Aligning the dosing head	17		
	Hydraulic connections	17		
	Connecting a leakage drain	19		
	Connecting the dosing head venting facility	19		
	Hydraulic accessories	20		
9	Electrical installation	27		
	Principles	27		
	Description of connection sockets	27		
10	Control	31		
	Operator controls of the control unit	31		

1 Notes to the Reader

These Operating instructions contain the information and rules of behaviour necessary for safe and correct operation of MAGDOS LP and MAGDOS LP-Net dosing pumps.

Follow these principles:

- Read the entire Operating instructions prior to commissioning the unit.
- Ensure that everyone who works with or on the dosing pump has read the operating instructions and follows them.
- Keep the operating instructions for the entire service life of the dosing pump.
- Pass on the operating instructions to any subsequent owner of the dosing pump.

1.1 General non-discrimination

In these operating instructions, only the male gender is used where grammar allows gender allocation. The purpose of this is to make the text easy to read. Men and women are always referred to equally. We would like to ask female readers for understanding of this text simplification.

1.2 Explanations of signal words

Different signal words in combination with warning signs are used in these Operating instructions. Signal words illustrate the gravity of possible injuries if the risk is ignored:

Signal word	Meaning
DANGER	Refers to imminent danger. Ignoring this sign may lead to death or the most serious injuries.
WARNING	Refers to a potentially hazardous situation. Ignoring this sign might lead to death or the most serious injuries.
CAUTION	Refers to a potentially hazardous situation. Ignoring this sign may lead to light injuries or damage to property.
NOTICE	Refers to a danger which, if ignored, may compromise the unit or its function.

Table 1-1: Explanations of signal words

1.3 Explanations of warning signs

Warning signs represent the type and source of a danger:







Warning sign	Type of danger
	General danger zone
	Danger of electric shock
	Danger of caustic or other burns.
	Danger of explosions
	Danger of magnetic radiation
	Danger of automatic start up
	Danger of damage to machine or compromised function.

Table 1-2: Explanations of warning signs

1.4 Identification of warnings

Warnings are intended to help you recognise risks and avoid negative consequences.

This is how warnings are identified:

Warning sign	SIGNAL WORD
<p>Description of danger. Consequences if ignored. ⇒ The arrow signals a precautionary measure to be taken to eliminate the danger.</p>	

1.5 Identification of instructions for action

This is how pre-conditions for action are identified:

- ✓ Pre-condition for action which must be met before taking action.

This is how instructions for action are identified:

➔ Separate step with no follow-up action.

1. First step in a series of steps.
2. Second step in a series of steps.
 - ▶ Result of the above action.

- ✓ **Action completed, aim achieved.**

2 Safety

2.1 General warnings

The following warnings are intended to help you to eliminate the dangers that can arise while handling the dosing pump. Risk prevention measures always apply regardless of any specific action.

Safety instructions warning against risks arising from specific activities or situations can be found in the respective sub-chapters.

 DANGER	<p>Danger to life due to electric shock</p> <p>Wrongly connected or located cables or damaged ones can injure you.</p> <ul style="list-style-type: none"> ⇒ Connect the device only to a socket outlet with earthing contact protected by a ground fault circuit interrupter (GFCI). ⇒ Replace damaged cables without delay. ⇒ Do not use extension cables. ⇒ Do not bury cables. ⇒ Secure cables to avoid being damaged by other equipment.
---	--

 DANGER	<p>Danger to life through explosions!</p> <p>When using dosing pumps without ATEX certification in a potentially explosive area, explosions can occur that result in fatal injuries.</p> <ul style="list-style-type: none"> ⇒ Never use the MAGDOS LP dosing pump in potentially explosive areas.
---	---

 WARNING	<p>Caustic burns or other burns through dosing media!</p> <p>After connecting the mains supply, residual dosing media in the dosing head can spray out.</p> <ul style="list-style-type: none"> ⇒ Before connecting the mains supply, connect the dosing lines. ⇒ Check that all the screw connections have been tightened correctly and are leak-proof.
--	--

 WARNING	<p>Caustic burns or other burns through dosing media!</p> <p>While working on the dosing head, valves and connections, you may come into contact with dosing media.</p> <ul style="list-style-type: none"> ⇒ Use sufficient personal protective equipment. ⇒ Rinse the dosing pump with a liquid (e.g. water) which does not pose any risk. Ensure that the liquid is compatible with the dosing medium. ⇒ Release pressure in hydraulic parts. ⇒ Never look into open ends of plugged pipelines and valves.
--	---

 WARNING	<p>Caustic burns or other burns through dosing media!</p> <p>The materials of the dosing pump and hydraulic parts of the system must be suitable for the dosing medium that is used. Should this not be the case, the dosing media may leak.</p> <ul style="list-style-type: none"> ⇒ Make sure that the materials you are using are suitable for the dosing medium. ⇒ Make sure that the lubricants, adhesives, sealants, etc. that you use are suitable for the dosing medium.
--	---

 WARNING	<p>Danger due to magnetic radiation for people with pacemakers!</p> <p>During operation solenoid diaphragm dosing pumps emit a stray magnetic field. If you do not keep far enough away, the function of a pacemaker can be negatively affected.</p> <ul style="list-style-type: none"> ⇒ People with pacemakers must always keep at least 50 cm away from the dosing pump..
--	--

 CAUTION	<p>Increased risk of accidents due to insufficient qualification of personnel!</p> <p>Dosing pumps and their accessories may only be installed, operated and maintained by personnel with sufficient qualifications. Insufficient qualification will raise the risk of accidents.</p> <ul style="list-style-type: none"> ⇒ Ensure that all action is taken only by personnel with sufficient and corresponding qualifications. ⇒ Prevent access to the system for unauthorised persons.
--	--

	CAUTION
<p>Danger of personal injury and material damage! Changing dosing media can lead to unpredictable reactions. ⇒ Thoroughly clean the dosing pump and appropriate sections of the plant to avoid chemical reactions.</p>	

2.2 Hazards due to non-compliance with the safety instructions

Failure to observe the safety instructions can pose a risk not only to the personnel, but consequentially to the environment and the unit.

The specific consequences can be:

- Failure of vital functions of the dosing pump and the system,
- failure of required maintenance and repair methods,
- danger for individuals through dangerous dosing media,
- danger to the environment through substances leaking from the system.

2.3 Safe operation

Besides the safety instructions specified in these Operating instructions, further safety rules apply and must be followed:

- Accident prevention regulations,
- safety and operating provisions,
- safety provisions for handling dangerous substances (mostly the safety data sheets to dosing media),
- environmental protection provisions,
- applicable standards and legislation.

2.4 Personal protective equipment

Based on the degree of risk posed by the dosing medium and the type of work you are carrying out, you must use corresponding protective equipment. Read the Accident Prevention Regulations and the Safety Data Sheets to the dosing media find out what protective equipment you need.

As a minimum, the following protective equipment is recommended:



Protective clothing



Protective gloves



Goggles

Corresponding protective equipment must be used during these tasks:

- Commissioning,
- working on the dosing pump while running,
- decommissioning,
- maintenance work,
- disposal.

2.5 Personnel qualification

Any personnel who work on the dosing pump must have appropriate special knowledge and skills.

Anybody who works with the dosing pump must meet the conditions below:

- Attendance at all the training courses offered by the owner,
- Personal suitability for the respective job,
- Sufficient qualification for the respective job,
- Training in handling of the dosing pump,
- Knowledge of safety equipment and the way this equipment functions,
- Knowledge of these Operating instructions, particularly of safety instructions and sections relevant for the job,
- Knowledge of fundamental regulations regarding health and safety and accident prevention.

All persons must generally have the following minimum qualification:

- Training as specialists to carry out work on the dosing pump unsupervised,
- Sufficient training that they can work on the dosing pump under the supervision and guidance of a trained specialist.

These Operating instructions differentiate these user groups:

2.5.1 Expert staff

Expert staff are able, thanks to their professional training, knowledge and experience as well as knowledge of the respective provisions, to do the job allocated to them and recognise and/or eliminate any possible dangers by themselves.

2.5.2 Trained person

Trained persons have been trained by the user into the tasks they are supposed to perform and into the dangers stemming from improper behaviour.

In the table below you can check what qualifications are the pre-condition for the respective tasks. Only people with appropriate qualifications are allowed to perform these tasks!

Qualification	Tasks
Expert staff	<ul style="list-style-type: none"> ■ Assembly ■ Hydraulic installations ■ Electrical installations ■ Maintenance ■ Repairs ■ Commissioning ■ Decommissioning ■ Disposal ■ Troubleshooting
Trained person	<ul style="list-style-type: none"> ■ Storage ■ Transportation ■ Control ■ Troubleshooting

Table 2-1: Personnel qualification

3 Appropriate and intended use

3.1 Notes on product warranty

Any non-designated use of the product can compromise its function or intended protection. This leads to invalidation of any warranty claims!

Please note that liability is on the side of the user in the following cases:

- The dosing pump is operated in a manner which is not consistent with these Operating instructions, particularly the safety and handling instructions and the chapter entitled "Appropriate and intended use".
- If people operate the product who are not adequately qualified to carry out their respective activities,
- No original spare parts or accessories of Lutz-Jesco GmbH are used,
- Unauthorised changes are made to the device by the user,
- The user uses different dosing media than those indicated in the order,
- The user does not use dosing media under the conditions agreed with the manufacturer such as modified concentration, density, temperature, contamination, etc.

3.2 Intended purpose

The MAGDOS LP dosing pump is intended for the following purpose: the conveying and dosing of liquids.

3.3 Device revision

This operating manual applies to the following devices:

Device	Month / year of manufacture	Firmware
MAGDOS LP	07/2012 onwards	1.27
MAGDOS LP-Net	07/2012 onwards	1.27

Table 3-1: Device revision

3.4 Principles

- Before delivery, the manufacturer inspected the dosing pump and operated it under specific conditions (with a specific dosing medium with a specific density and temperature, with specific pipe dimensions, etc.) Since these conditions vary at every installation location, you must calibrate the dosing pump after delivery. For information on the calibration procedure refer to „Calibrating the dosing pump“ (see page 39). For details on the approximate values and the capacity of the dosing pump, refer to the chapter entitled „Delivery characteristic curves“ (see page 55).
- Information on the usage and environment (see „Technical Data“ on page 12) applies.
- Any restrictions regarding the viscosity, temperature and density of dosing media must be followed. You must only use dosing media at temperatures above freezing point or below the boiling point of the respective medium.
- The materials of the dosing pump and hydraulic parts of the system must be suitable for the dosing medium that is used. In this connection, note that the resistance of these components can change in dependence on the temperature of the media and the operating pressure.



Information on the suitability of materials combined with different dosing media can be found in the Chemical Resistance List of Lutz-Jesco GmbH. The information in this resistance list is based on information from the material manufacturers and on expertise obtained by Lutz-Jesco from handling the materials. As the durability of the materials depends on many factors, this list only constitutes initial guidance on selecting material. In all cases, test the equipment with the chemicals you use under operating conditions.

- The dosing pump is not intended for outdoor use unless appropriate protective measures have been taken.
- Avoid leaks of liquids and dust into the casing and avoid direct exposure to sunlight.
- You must never operate dosing pumps in a potentially explosive atmosphere if they do not have corresponding nameplates or an appropriate EC Declaration of Conformity for potentially explosive atmospheres.

3.5 Prohibited dosing media

The dosing pump must not be used for these media and substances:

- Gaseous media,
- radioactive media,
- solid substances,
- combustible media,
- all other media that are not suitable for delivery using this dosing pump.

3.6 Foreseeable misuse

Below, there is information about the applications of the dosing pump or associated equipment that are not considered to be intended use. This chapter is intended to allow you to detect possible misuse in advance and to avoid it.

Foreseeable misuse is assigned to the individual stages of the product lifetime:

3.6.1 Faulty assembly

- Unstable or unsuitable bracket
- Dosing pump bolted wrongly or loosely

3.6.2 Faulty hydraulic installation

- Suction and pressure lines dimensioned incorrectly
- Unsuitable connection of the pipes due to wrong material or unsuitable connections.
- Suction and pressure lines mixed-up
- Damage to threads due to them being tightened too much
- Bending of pipelines
- No free return flow of the pressure relief valve
- Excessive demand due to the pressure differences between the suction and discharge valves
- Through-suction at installation without pressure control valves
- Damage due to undamped acceleration mass forces
- Exceeding the admissible pressure on the suction and discharge sides
- Using damaged parts

3.6.3 Faulty electrical installation

- Connecting the mains voltage without a protective earth
- Unsecured mains or one that does not conform to standards
- Not possible to immediately or easily disconnect the power supply
- Wrong connecting cables for mains voltage
- Dosing pump accessories connected to wrong sockets
- Diaphragm monitoring not connected or defective
- Protective earth removed

3.6.4 Faulty commissioning

- Commissioning with damaged plant
- Shut-off valves closed at commissioning
- Closed suction or pressure line, e.g. due to blockages
- Personnel was not informed before commissioning
- System was recommissioned after maintenance without all the protective equipment and fixtures, etc. being reconnected.
- Inadequate protective clothing or none at all

3.6.5 Faulty operation

- Protective equipment not functioning correctly or dismantled
- Modification of the dosing pump without authority
- Ignoring operational disturbances
- Elimination of operational disturbances by personnel without adequate qualifications

- Deposits in the dosing head due to inadequate purging, particularly with suspensions
- Bridging the external fuse
- Operation made more difficult due to inadequate lighting or machines that are difficult to access
- Operation not possible due to dirty or illegible display of the dosing pump
- Delivery of dosing media for which the system is not designed
- Delivery of particulate or contaminated dosing media
- Inadequate protective clothing or none at all

3.6.6 Faulty maintenance

- Carrying out maintenance during ongoing operation
- Carrying out work that is not described in the operating instructions
- No adequate or regular inspection of correct functioning
- No replacement of damaged parts or cables with inadequate insulation
- No securing against reactivation during maintenance work
- Using cleaning materials that can cause reactions with the dosing media
- Inadequate cleaning of the system
- Unsuitable purging medium
- Unsuitable cleaning materials
- Cleaning materials left in system sections
- Using unsuitable cleaning equipment
- Using the wrong spares or lubricants
- Contaminating the dosing medium with lubricant
- Installing spares without following the instructions in the operating manual
- Blocking venting orifices
- Pulling off sections of the plant
- Contamination at installation without a dirt trap
- Mixing up the valves
- Mixing up the sensor lines
- Not reconnecting all the lines
- Damaging or not installing all the seals
- Not renewing seals
- Not paying attention to safety data sheets
- Inadequate protective clothing or none at all

3.6.7 Faulty decommissioning

- Not completely removing the dosing medium
- Dismantling lines while the dosing pump is running
- Device not disconnected from the power supply
- Using the wrong dismantling tools
- Inadequate protective clothing or none at all

3.6.8 Faulty disposal

- Incorrect disposal of dosing media, operating resources and other materials
- No labelling of hazardous substances

4 Product Description

4.1 Properties

The MAGDOS LP is a Solenoid-Diaphragm Dosing Pump that is used when precise dosing results are required.

They are characterized by the following properties:

- Output range from 0.5 to 15 l/h, up to 16 bar,
- Reproducible dosing precision of $\pm 2\%$,
- Integrated automatic dosing head venting facility (except with stainless steel dosing heads),
- Suitable for highly aggressive or poisonous dosing media,
- Operating modes: Manual mode, analog input, pulse input, batch mode and network mode (MAGDOS LP-Net only),
- Graphic display: 128 x 64 px, 1.5", monochrome, illuminated,
- Menu languages: English, German, French, Spanish, Portuguese, Dutch,
- Four multifunction keys for operator inputs,
- Real-time clock and date,
- Floor- and wall-mounting options,
- Release code and security code,
- Calibration option,
- 2 Eco-Mode energy-saving modes,
- Connections: M12x1 connector, A-, B- or D-coded,
- Ethernet, network connection (MAGDOS LP-Net only).

4.2 Scope of delivery

Please compare the delivery note with the scope of delivery. The following items are part of the scope of delivery:

- MAGDOS LP dosing pump,
- One set each of clamping connections for the suction and discharge sides for hoses with diameters of 4/6 mm, 6/9 mm and 6/12 mm (made of PVC, PP and PVDF),
- 5 (MAGDOS LP) or 6 (MAGDOS LP-Net) covering caps for electrical connections (mounted on the dosing pump),
- Mains cable,
- Operating Manual,
- Inspection report and test certificate (optional),
- Accessory kit (optional).

4.3 Structure of the dosing pump

4.3.1 General Overview

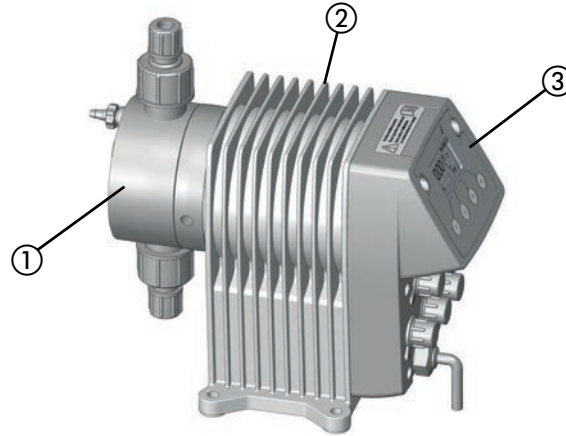

Fig. 4-1: Overview of MAGDOS LP dosing pump

No.	Description
①	Dosing head
②	Drive unit
③	Control unit

Table 4-1: Designation of components

4.3.2 Dosing head

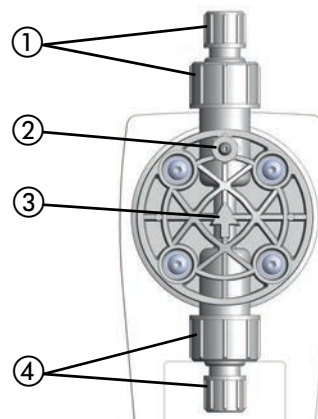

Fig. 4-2: Dosing head

No.	Description
①	Valve and connection on the discharge side
②	integrated dosing head venting facility (plastic version only)

Table 4-2: Designation of components

No.	Description
③	Arrow indicating the direction of throughflow of the dosing medium
④	Valve and connection on the suction side

Table 4-2: Designation of components

4.3.3 Control elements



Fig. 4-3: Controller of MAGDOS LP dosing pump

No.	Description
①	Graphic display
②	Multifunction keys on the control unit for operator inputs
③	Connection sockets for external operation or connecting accessories
④	Mains cable for power supply

Table 4-3: Designation of components

4.4 Function description

Dosing pumps are positive displacement pumps. They are used if precisely defined delivery of a medium is necessary. A constant volume per stroke or time is delivered.

The system delivers or meters the dosing medium by means of a repeated sequence of suction strokes followed by pressure strokes. This results in a pulsing flow.

If the dosing pump is in the suction stroke phase, the diaphragm is pulled into the rear final position. Due to the resulting vacuum in the dosing head, the discharge valve closes, the suction valve opens and dosing medium flows from the suction line into the dosing head.

If the dosing pump is in the pressure stroke phase, the diaphragm is moved into the front final position. Due to the pressure in the dosing head, the suction valve closes and the dosing medium flows through the discharge valve from the dosing head into the pressurised pipe.

4.5 Nameplate

There is information on the equipment about safety or the product's way of functioning. The information must stay legible for the duration of the service life of the product.

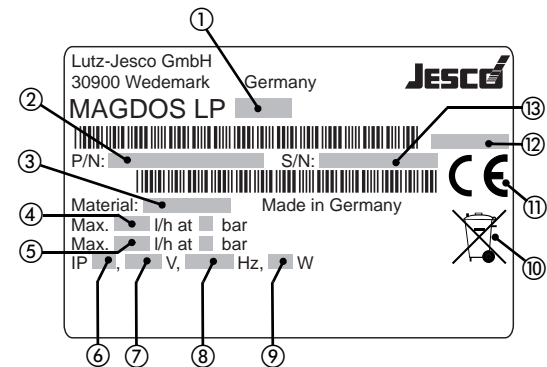

Fig. 4-4: MAGDOS LP nameplate

No.	Description
①	Product, type, nominal size
②	Part number
③	Type of material of dosing head/ type of material of seals
④	Maximum delivery capacity at average pressure
⑤	Maximum delivery capacity at maximum pressure
⑥	Protection class
⑦	Voltage supply
⑧	Frequency
⑨	Power consumption
⑩	WEEE label
⑪	Label showing conformity with applicable European directives
⑫	Month / year of manufacture
⑬	Serial number

Table 4-4: Nameplate

5 Technical Data

5.1 Delivery capacity data

Please note that some of this data only represents guide values. The actual capacity of a dosing pump depends on various factors. For approximate values of the delivery capacity at different pressures, refer to „Delivery characteristic curves“ (see page 55).

Information	Value	MAGDOS LP size						
		05	1	2	4	6	10	15
Delivery capacity at max. backpressure	l/h	0.36	0.76	1.9	3.4	6.2	9.0	13
	ml/stroke	0.05	0.05	0.2	0.31	0.57	0.83	0.86
max. back pressure	bar	16				8	6	3
Max. delivery pressure in Eco-Mode 1*	bar	10				6	4	2
Max. delivery pressure in Eco-Mode 2*	bar	6				4	2	1
Delivery capacity at average backpressure	l/h	0.54	1.1	2.3	3.8	6.8	10	15
	ml/stroke	0.08	0.07	0.24	0.35	0.63	0.92	1.0
Average back pressure	bar	8				4	3	1
Max. stroke frequency	RPM	120	250	160	180			250
Suction head for non-gassing media (suction line filled)	mWS	5		3		2		

Table 5-1: Output data

* In the case of operation in Eco-Mode energy saving mode, the delivery capacity is 5-10 % less than in normal mode (with the same backpressure). If necessary, recalibration may be necessary (see „Calibrating the dosing pump“ on page 39).

5.2 Operating conditions and limits

Information	Value	MAGDOS LP size
		05 – 15
Permitted ambient temperature	°C	5 – 45 (5 – 40 with PVC parts)*
Relative humidity	%	Max. 90
Max. sound pressure level (depressurised)	dB(A)	68 – 75
Max. sound pressure level (at test pressure)	dB(A)	65 – 70
Max. supply pressure	mbar	800
Viscosity limits	mPa s	300** / 1000***
Adjustable dosing range	%	0 – 100

Table 5-2: Operating conditions and limits

* Use of dosing pumps at ambient temperatures of under 5 °C has to be checked individually. In those cases please contact the manufacturer.

** With a viscosity of ~300 mPa s and above, you must use spring-loaded valves.

*** If the viscosity is above 1000 mPa s, this must be checked individually and the stroke frequency must be between 50 and 100 strokes/min.

5.2.1 Permitted temperature of the medium

Information	Value	MAGDOS LP (all sizes)
Dosing head made of PVC	°C	0 – 35
Dosing head made of PP	°C	0 – 60
Dosing head made of PVDF	°C	0 – 80
Dosing head made of stainless steel 1.4571	°C	0 – 80

Table 5-3: Permitted temperature of the medium

5.3 Electrical data

Information	Value	MAGDOS LP size						
		05	1	2	4	6	10	15
Voltage supply		110 - 240 V AC, -10% / +5%. 50/60 Hz						
Power consumption	W	10	15	21	27	28	29	26
Max. current consumption during dosing stroke	A	2.0		3.0	3.7	3.8	4.1	3.6
Eco-Mode 1								
Power consumption	W	8	11	17	18	20	22	19
Max. current consumption during dosing stroke	A	1.7		2.5	2.9	3.1	3.6	2.9
Eco-Mode 2								
Power consumption	W	7	10	13	14	17	16	15
Max. current consumption during dosing stroke	A	1.5		2	2.2	2.7		2.4

Table 5-4: Electric data

5.4 Other data

Information	Value	MAGDOS LP size						
		05	1	2	4	6	10	15
Weight (with dosing head made of PVC, PP or PVDF)	kg	~ 3.2						
Weight (with dosing head made of stainless steel)	kg	~ 4.3						
Diameter of diaphragm	mm	24		33		39		
Electrical cable	m	1.8 m (with mains plug)						
Protection class		IP 65 (with covering caps on the connections)						
Insulation class		F						
Valve connection		G 5/8 external						
Valve size		DN3			DN4			

Table 5-5: Other data

6 Dimensions

6.1 MAGDOS LP with dosing head made of PVC, PP or PVDF

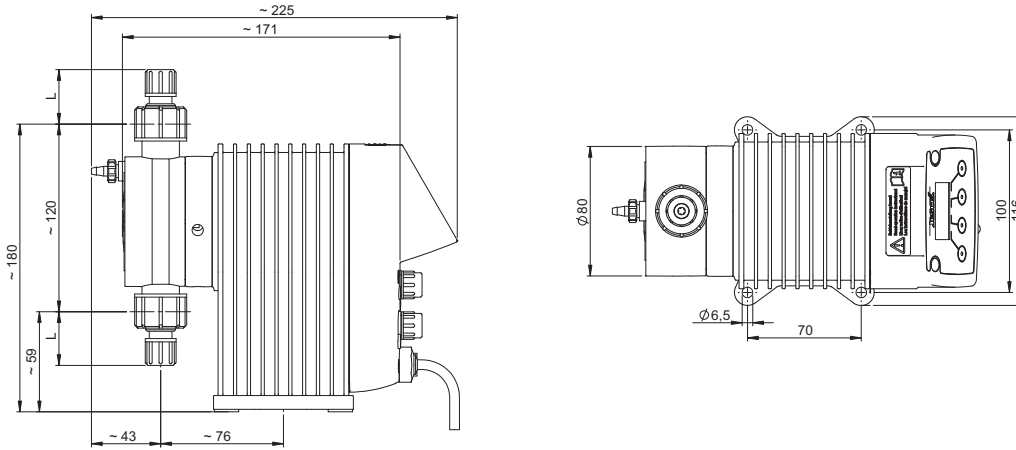

Fig. 6-1: Dimensioned drawing of MAGDOS LP with dosing head made of PVC, PP or PVDF (all dimensions in mm)

Connection	Material	Size	Nominal diameter	L
Hose clip	PVC / PP / PVDF	4/6 mm	DN4	31
		1/4x3/8"	1/4"	34
		6/9 mm	DN6	34
		6/12 mm	DN6	15

6.2 MAGDOS LP with dosing head made of stainless steel (1.4571)

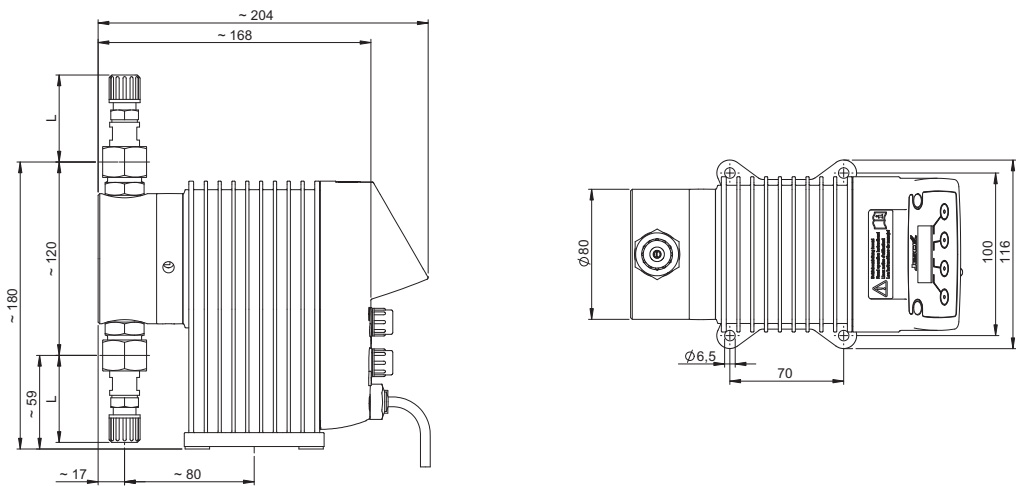



Fig. 6-2: Dimensioned drawing of MAGDOS LP with dosing head made of stainless steel 1.4571 (all dimensions in mm)

Connection	Material	Size	Nominal diameter	L
Hose clip	Stainless steel (1.4571) / PVDF	4/6 mm	DN4	50
Hose clip	Stainless steel (1.4571) / PVDF	6/9 mm	DN6	54

7 Installing the Dosing Pump

	DANGER
Danger to life due to electric shock!	
Electrically conductive liquid can enter pump housings, cable screw connections and mains connectors.	
⇒ Make sure that all protective measures comply at least with the requirements of protection class IP 65.	
⇒ Always set up the dosing pump such that water cannot enter the housing.	

	CAUTION
Danger of personal injury and material damage!	
A dosing pump that is difficult to access represents a danger due to incorrect operation and faulty maintenance.	
⇒ Install the dosing pump such that it is accessible at all times.	

7.1 Set up information

When installing, follow the basic principles below:

- The valves must be vertical: Discharge valve at top, suction valve at bottom. In this connection, pay attention to the arrow on the dosing head. The dosing head must be aligned such that the arrow points vertically upwards.
- You should install the dosing pump at a convenient height for operation.
- It must not be installed under the ceiling.
- The frame of foundation for fixing the dosing pump must not be subjected to jolts. The pump must be vibration-free and stable.
- There must be enough free space in the area of the dosing head and the suction and discharge valves for these parts to be easily dismantled if required. The entire space requirement for installation and maintenance is approximately 1 m².
- The distance from the sides of the dosing pump to the wall or other dosing pumps or equipment must be at least 3 cm. There must be a guaranteed flow of circulating air.
- The maximum ambient temperature must be complied with, see "Operating conditions and limits" on page 12. If necessary, radiated heat from surrounding equipment must be screened.
- Avoid exposure to direct sunlight.
- The dosing pump is not intended for use out of doors unless appropriate protective measures have been taken to prevent dust and water from entering the housing.
- For the dimensions of the fastening holes, refer to „Dimensions“ (see page 14).
- The tightening torque for the fastening bolts is 1.5 - 2 Nm.

7.2 Installation examples

7.2.1 Installation on a wall bracket

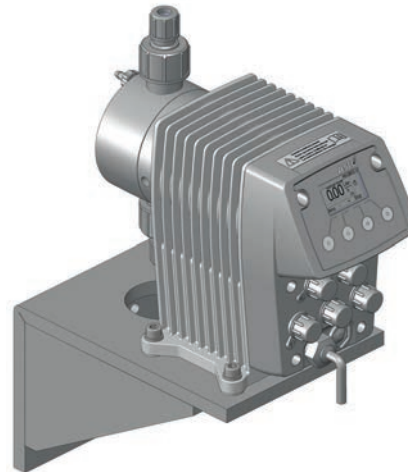

Fig. 7-1: Installation on a wall bracket

To reduce the structure-borne noise, the dosing pump is bolted to the wall bracket using rubber elements. The materials necessary for this are included with the wall bracket.

7.2.2 Installation on the wall





Fig. 7-2: Installation on the wall

The dosing pump can be mounted to the floor or directly to the wall without the need for additional elements. Turn the dosing head appropriately to ensure the flow direction of the medium through the dosing head.

8 Hydraulic installation

In this chapter, you will find information about the hydraulic parts of a system that you should install or that can install additionally. In many cases, you must install hydraulic accessories to be able to use all the functions that the dosing pump MAGDOS LP offers, to guarantee functional safety or to achieve a high level of dosing precision.

	WARNING
<p>Caustic burns or other burns through dosing media!</p> <p>The materials of the dosing pump and hydraulic parts of the system must be suitable for the dosing medium that is used. Should this not be the case, the dosing media may leak. Depending on the type and hazardousness of the dosing medium, this can result in injury.</p> <ul style="list-style-type: none"> ⇒ Make sure that the materials you are using are suitable for the dosing medium. ⇒ Make sure that the lubricants, adhesives, sealants, etc. that you use are suitable for the dosing medium. 	

	WARNING
<p>Caustic burns or other burns through dosing media!</p> <p>If there is a diaphragm rupture, the dosing medium can escape in an uncontrolled way. Depending on the type and hazardousness of the dosing medium, this can result in injury.</p> <ul style="list-style-type: none"> ⇒ Install a leakage drain. 	

	WARNING
<p>Caustic burns or other burns through dosing media!</p> <p>The dosing pump can generate a pressure that is many times the rated one. A blocked pressure line can lead to dosing medium escaping. Depending on the type and hazardousness of the dosing medium, this can result in injury.</p> <ul style="list-style-type: none"> ⇒ Install pressure relief valves. 	

	CAUTION
<p>Danger of personal injury and material damage!</p> <p>High peak pressures can lead to piping vibrating and cause them to snap. This can result in injury due to uncontrollable piping or escaping dosing media.</p> <ul style="list-style-type: none"> ⇒ Install pulsation dampeners. 	

	NOTICE
<p>Damage to drives due to overloading</p> <p>The pressure conditions between the suction and discharge sides must be balanced; otherwise, overloading can result. This can lead to uncontrolled dosing processes, damage to the plant pipework and to the dosing pump.</p> <ul style="list-style-type: none"> ⇒ Ensure that the pressure on the discharge side is at least 1 bar than on the suction side. 	

	NOTICE
<p>Locking of threads</p> <p>Stainless steel and plastic parts (particularly those made of PVC) that are bolted together in a detachable connection (e.g. the dosing head and the valves) can lock. This makes them difficult to release.</p> <ul style="list-style-type: none"> ⇒ Before bolting, grease the corresponding parts with a lubricant, e.g. PTFE spray). Ensure that the lubricant is compatible with the dosing medium. 	

8.1 Dimensioning of the system

- The dosing pump's technical data (see „Technical Data“ on page 12) must be taken into account and the plant's layout must be set up appropriately (e.g. pressure loss when rating the lines with regard to their nominal diameter and length).
- You must design the entire plant and its integrated dosing pump such that escaping dosing medium due to the failure of wearing parts such as the diaphragm, or to burst hoses does not lead to permanent damage to parts of the system or the premises.
- The leakage opening of the dosing head must be visible so that you can detect a diaphragm failure. It must be possible for the outflow from the leakage drain to be on a free downwards gradient.
- If you use hazardous dosing media, the installation must be designed such that no disproportionately high consequential damages arise due to dosing media escaping.
- To avoid dosing errors after the end of the process, the dosing pump must be locked hydraulically.
- To allow you to easily inspect the pressure conditions in the system, you should provide connections for pressure gauges close to the suction and discharge valves.

8.2 System piping

- The system piping must not exert any force on the connections and valves of the dosing pump.
- This means that steel piping should be connected to the dosing pump by means of flexible pipe sections.
- The nominal diameters of the pipework and the installed fittings should be rated the same as or greater than the nominal diameters of the dosing pump's suction and discharge valves.
- The suction line should be kept as short as possible.
- You should avoid intertwined hoses.
- Avoid loops, since air bubbles can collect.

8.3 Aligning the dosing head

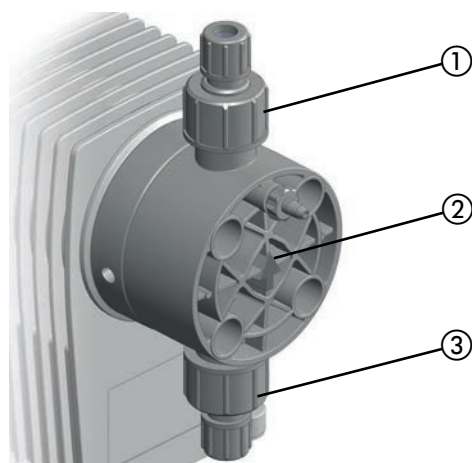

Fig. 8-1: Aligning the dosing head

When connecting the dosing lines to the dosing pump, you must observe the direction of through-flow (see arrow ②). The dosing head must be aligned vertically.

The suction valve ③ must always point downwards. Accordingly, arrow ② and pressure valve ④ always point upwards. This is irrespective of the positioning of the dosing head to the drive.

8.4 Hydraulic connections

8.4.1 Connecting hose clips

Choose the hose connection according to the condition of the hose (material, inner diameter, wall thickness) in order to ensure maximum pressure resistance.

8.4.1.1 Sizes 4/6 and 6/9

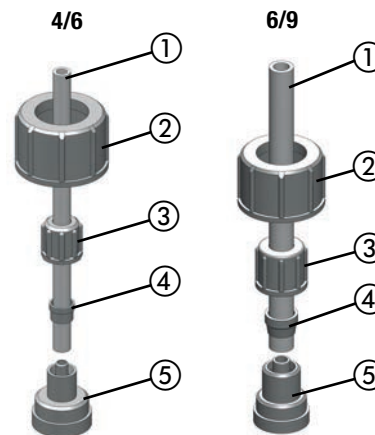

Fig. 8-2: Hose clips 4/6 and 6/9 (internal and external diameters in mm)

Perform the following working steps:

1. Cut the hose ① to length neatly and at an exact right angle.
2. Place a gasket that is suitable for the dosing medium between the connection ⑤ and the valve.
3. Screw the connecting piece ⑤ to the dosing pump's valve using the ②.
4. Thread the union nut ③ and the clamping ring ④ onto the hose.
5. Plug the hose ① all the way in to the grommet of connection piece ⑤.
6. Push the clamping ring ④ onto the grommet of connection piece ⑤ and screw it to the union nut ③.
7. Carry out the same procedure with the connection to the dosing pump's other valve.

✓ **Hose clip connected.**

8.4.1.2 Size 6/12

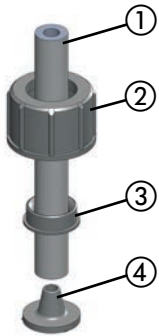

Fig. 8-3: Hose clip 6/12 (internal and external diameter in mm)

Size 6/12 hose clips only have a union nut. It clamps the hose onto the grommet of the connection piece and at the same time fastens on the dosing pump's valve.

Perform the following working steps:

1. Cut the hose ① to length neatly and at an exact right angle.
2. Place a gasket that is suitable for the dosing medium between the connection ④ and the valve.
3. Push the union nut ② and the cutting ring ③ over the hose ①.
4. Press the end of the hose ① onto the grommet of connection piece ④. You can do this more easily by moistening the end of the hose on the inside or applying some lubricant to the grommet in the cone area. You should push at least two thirds of the hose onto the grommet of the connection piece.
5. Push the cutting ring ③ over the hose ① into the cone area on the grommet of connection piece ④.
6. Screw the union nut ② onto the valve of the dosing pump.

✓ **Hose clip connected.**

8.4.2 Making the bonded connection

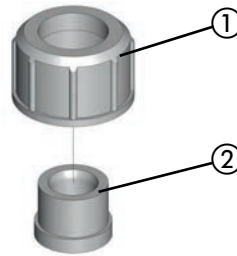

Fig. 8-4: Bonded connection

Perform the following working steps:

1. Cut the PVC tube to length.
2. Push the union nut onto the tube.
3. Stick the bonded coupling sleeve ② to the tube (follow the instructions of the adhesive manufacturer).
4. Screw the union nut onto the valve of the dosing pump. Use a gasket that is suitable for the dosing medium.

✓ **Bonded connection made.**

8.4.3 Making the cemented connection

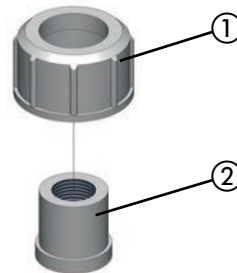

Fig. 8-5: Cemented conn.

Perform the following working steps:

1. Cut the tube to length.
2. Cut the thread ② onto the end of the tube.
3. Push the union nut ① onto the tube.
4. Seal the thread ②. When choosing your sealing material, take into account its resistance to material, temperature and pressure.
5. Screw the union nut onto the valve of the dosing pump. Use a gasket that is suitable for the dosing medium.

✓ **Cemented connection made.**



Under normal conditions, you only need to screw the hydraulic connections finger-tight. However, due to the material settling, the pre-tension of the screw connection can slacken. This means that you must re-tighten the screw connection before carrying out commissioning.

8.5 Connecting a leakage drain

Lutz-Jesco GmbH dosing pumps are produced to the highest quality standards and have a long service life. However, some parts are subject to operational wear. This is the case particularly with the diaphragms that are continuously subjected to forces during the suction and discharge strokes and to the effects of the dosing medium.

If a diaphragm ruptures, the dosing medium starts to leak. This leakage is drained via the leakage opening. On the flange of the dosing head, there are three openings for this purpose. Depending on the alignment of the dosing pump, the leakage is drained via the downward opening.

It is advisable to use a diaphragm rupture sensor (see „Diaphragm rupture sensor leak sensor“ on page 20).

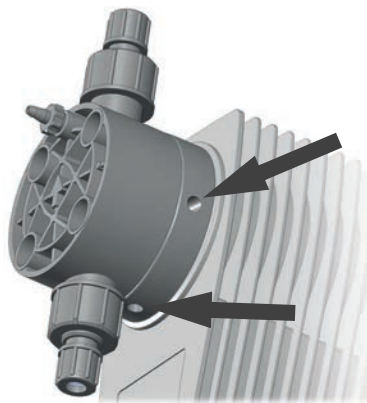

Fig. 8-6: Openings of the leakage drain

8.6 Connecting the dosing head venting facility

The MAGDOS LP dosing heads have an integrated dosing head venting facility (except for dosing heads made of stainless steel).

For the procedure when venting, refer to “Venting the dosing pump” on page 39.

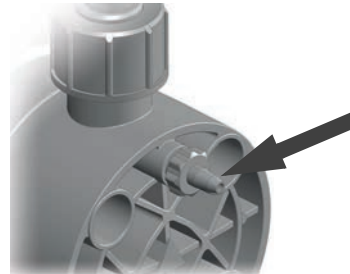

Fig. 8-7: Dosing head venting facility with hose connection

Perform the following working steps:

1. Connect a 4/6 hose to the dosing head venting facility.
2. Route the other end of the hose into the dosing tank or a collecting tank.

✓ **Dosing head venting facility connected.**



NOTICE

Damage to drives due to effervescent media

If a hose is connected to the leakage drain and it is routed back into the dosing tank, effervescent media can enter the drive and damage it.

⇒ Collect the leakage in a collecting pan.

⇒ As an alternative, you can route the leakage back to the dosing tank using a funnel. You should install the funnel at an adequate distance from the leakage opening.

8.7 Hydraulic accessories

The following chapter is intended to give you an overview of installation options.

Please note that these operating instructions are no substitute for the instructions supplied with the accessories in each case. The corresponding documentation supplied with the product applies to safety information and provides exact instructions on assembly.

8.7.1 Injection nozzle

If the pressure line enters a main line, it is advisable to install an injection nozzle.

Injection nozzles have three main functions:

- Dosing the medium into a main line,
- Preventing flowback into the pressure line through a non-return valve.

Notes on assembly:

- Double-ball injection nozzles must be installed into the main line vertically from the bottom. You can install hose and spring-loaded injection nozzles any way you like.
- With dosing media that tend to crystallize, it is advisable to carry out installation into the main line from the bottom. This prevents air bubbles from being trapped.
- Many dosing media tend to contaminate the injection nozzles, which can lead to blockages. In cases like this, it is advisable to install an injection nozzle that is easy to dismantle and block off.

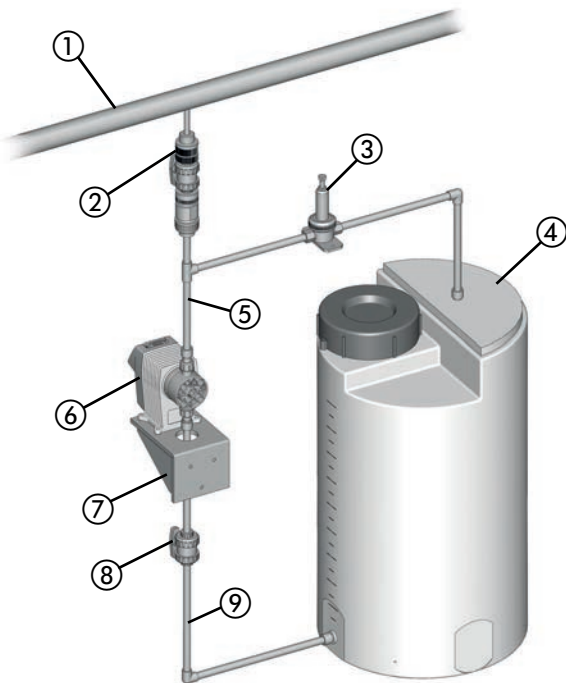

Fig. 8-8: Installation with an injection nozzle

No.	Description
①	Main line
②	Injection nozzle with shut-off valve
③	Pressure relief valve
④	Chemical tank
⑤	Pressure line
⑥	MAGDOS LP dosing pump
⑦	Wall bracket
⑧	Shutoff valve
⑨	Suction line

Table 8-1: Designation of components

8.7.2 Diaphragm rupture sensor leak sensor

If a diaphragm ruptures, the dosing medium starts to leak. The leakage is drained via the leakage opening.

As an option, the MAGDOS LP dosing pump is supplied with a leak sensor in the diaphragm flange; in the case of a diaphragm rupture, the sensor passes on a signal to the dosing pump and stops it. The system shows a "Diaphragm rupture" message on the display and reports a disturbance. The dosing pump cannot restart until you press **Start**.

You must first replace the diaphragm and clean dosing medium residue from the diaphragm flange. There must be no conducting connection between the two rings of the leak sensor.

The connecting cable of the leak sensor has an M12x1 male connector that you connect to connection socket 5 (see „Connection socket 5“ on page 29).

For an explanation of the icons, see "Set "Diaphragm rupture" menu item" on page 34.



Fig. 8-9: MAGDOS LP with leak sensor in the diaphragm flange

8.7.3 Contact Water Meter

The Contact Water Meter measures the throughflow in a pipe and sends a pulse to the dosing pump, which then starts dosing. This means that ideal proportional dosing is also possible with large throughflow fluctuations.

The connecting cable of the Contact Water Meter has an M12x1 male connector that you connect to connection socket 2 (see „Connection socket 2“ on page 28).

You determine the ratio of throughflow and executed strokes of the dosing pump in "Pulse input" mode, (see „Water meter“ on page 43).



Fig. 8-10: MAGDOS LP installation on contact-type water meter

8.7.4 Pressure relief valve

Pressure relief valves have an important safety function for protecting the dosing pump and the associated pipes and fittings. The dosing pump can generate a pressure that is many times the rated one. A blocked pressure line can lead to dosing medium escaping.

An inadmissibly high pressure can occur if:

- the shut-off valves are closed even though the dosing pump is running,
- pipes block.

At an appropriate pressure, a pressure relief valve opens a bypass line and protects the system in this way from pressures that are too high.

Notes on assembly:

- The line for returning dosing medium from the pressure relief valve must be routed to the dosing tank or to a collecting pan.
- The pressure in the dosing tank must not be too high so that it is possible to accommodate the returned dosing medium.
- As an alternative, the system can return dosing medium into the suction line in front of the dosing pump. In this case, there must not be a non-return valve or a foot valve in the suction line.
- You should install the pressure relief valve as close as possible to the dosing head.

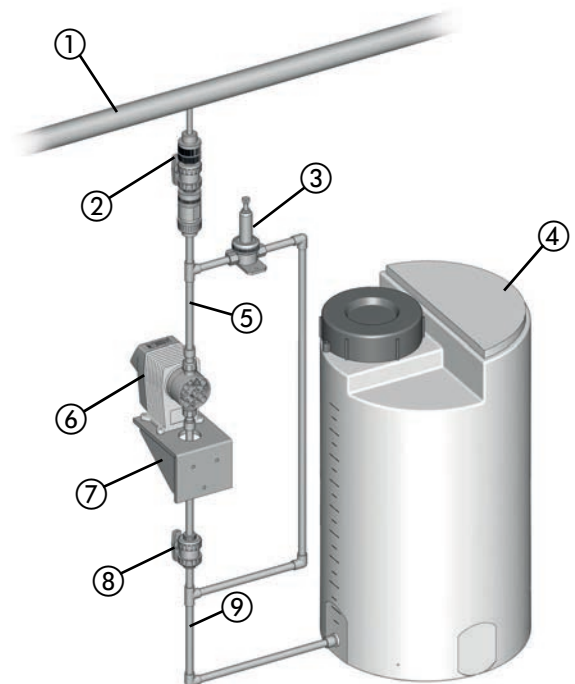

Fig. 8-11: Installation with pressure relief valve – returning to the suction line

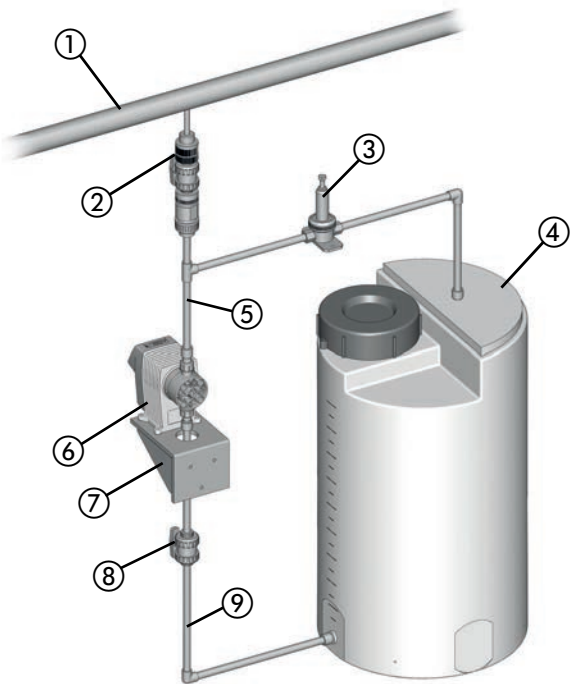

Fig. 8-12: Installation with pressure relief valve – returning to the dosing tank

No.	Description
①	Main line
②	Injection nozzle with shut-off valve
③	Pressure relief valve
④	Chemical tank
⑤	Pressure line
⑥	MAGDOS LP dosing pump
⑦	Wall bracket
⑧	Shutoff valve
⑨	Suction line

Table 8-2: Designation of components

8.7.5 Pressure control valve

Pressure control valves are necessary if:

- there are considerably fluctuating system pressures,
- the pressure on the suction side is higher than on the discharge side or if you intend to carry out dosing into depressurized lines.

In cases like this, if you do not use a pressure control valve, imprecise dosing results will occur or overloading will result. The pressure control valve solves these problems by generating a defined, constant back-pressure.

In some circumstances, a pressure control valve is unnecessary if you use a hose injection nozzle and if the backpressure that it generates is adequate.

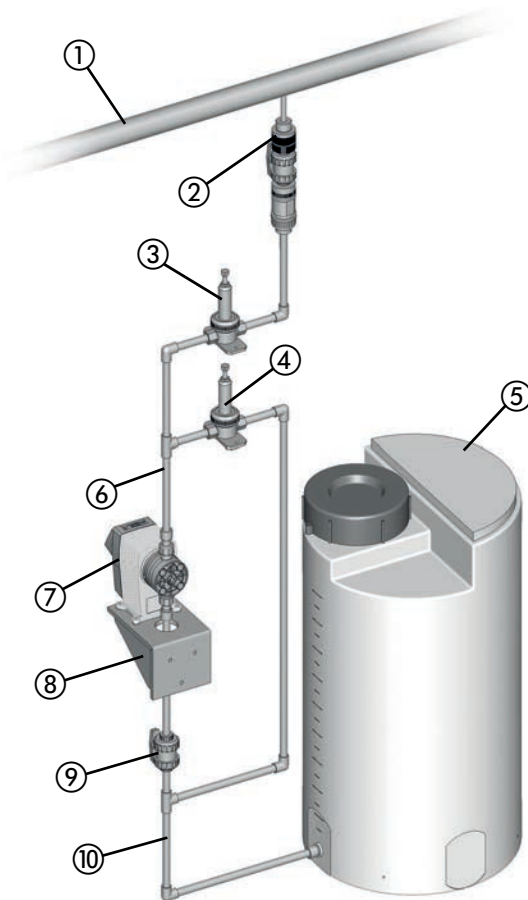

Fig. 8-13: Installation with a pressure control valve

No.	Description
①	Main line
②	Injection nozzle with shut-off valve
③	Pressure control valve
④	Pressure relief valve
⑤	Chemical tank

Table 8-3: Designation of components

No.	Description
⑥	Pressure line
⑦	MAGDOS LP dosing pump
⑧	Wall bracket
⑨	Shutoff valve
⑩	Suction line

Table 8-3: Designation of components

8.7.6 Pulsation dampener

Pulsation dampeners have the following functions:

- Damping pulsating delivery flows for processes that require low-pulsation dosing,
- Reducing the throughflow resistance with long pipelines.

When installed on the suction side:

- Damping of acceleration mass forces and with this reduction of wear on the dosing pump.
- Preventing cavitation (pull-off of the liquid column) due to too high acceleration.

However, pulsation dampeners also have important safety functions, since they prevent pressure peaks from arising that lead to piping vibrating and cause them to snap.

This problem can occur:

- with the high amplitudes of the vibrations,
- when using long pipes (the severity of the pulsation increases with the length of the pipe),
- when using rigid piping instead of elastic hoses.

Notes on assembly:

- You should carry out assembly in the direct vicinity of the location where you want to damp the pressure peaks (directly in front of the suction valve or directly behind the discharge valve).
- Pulsation dampeners should be installed with throttle valves or pressure control valves installed directly behind them. By setting the valves appropriately, you can further-optimize damping of the pulsations.
- To prevent unnecessary pipe friction losses, you should lay the connecting line straight and in accordance with the rated width of the pulsation dampener.
- You must separately fasten relatively large pulsation dampeners and ones with hose connections.
- Pipelines must not transfer any mechanical tensions onto the pulsation dampener.

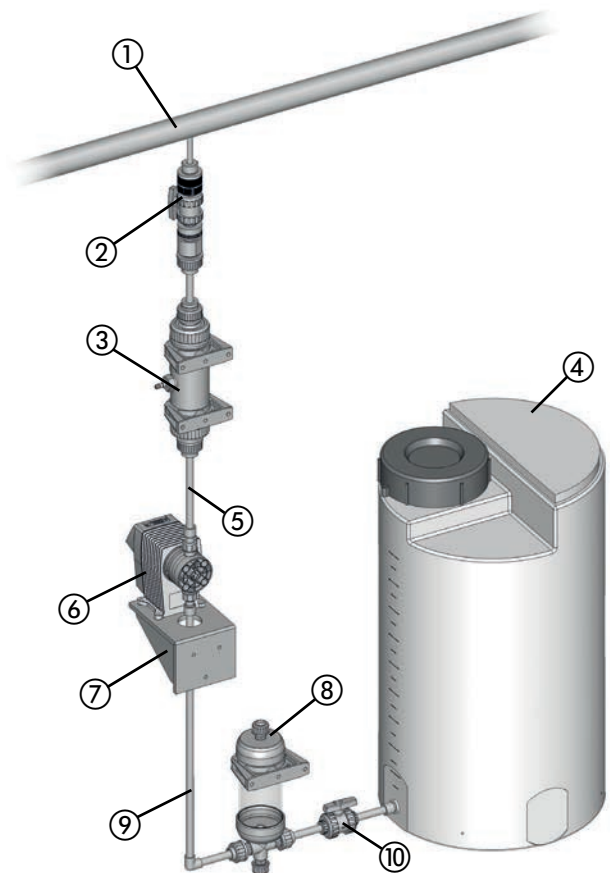

Fig. 8-14: Installation with a pulsation dampener

No.	Description
①	Main line
②	Injection nozzle with shut-off valve
③	Pulsation dampener
④	Chemical tank
⑤	Pressure line
⑥	MAGDOS LP dosing pump
⑦	Wall bracket
⑧	Suction pulsation dampener
⑨	Suction line
⑩	Shutoff valve

Table 8-4: Designation of components

8.7.7 Priming aid

Priming aids are particularly advisable:

- in the case of dosing pumps with small volumetric displacements per stroke or with low stroke length settings,
- with high suction heads,
- with highly dense dosing media,
- at priming for the first time due to dry valves and air in the suction line and the dosing head,
- in dosing systems with frequent downtimes.

Further advantages resulting from priming aids:

- preventing cavitation in the suction line,
- gas removal,
- optical dosing control with small amounts,
- smoothing of the suction flow.

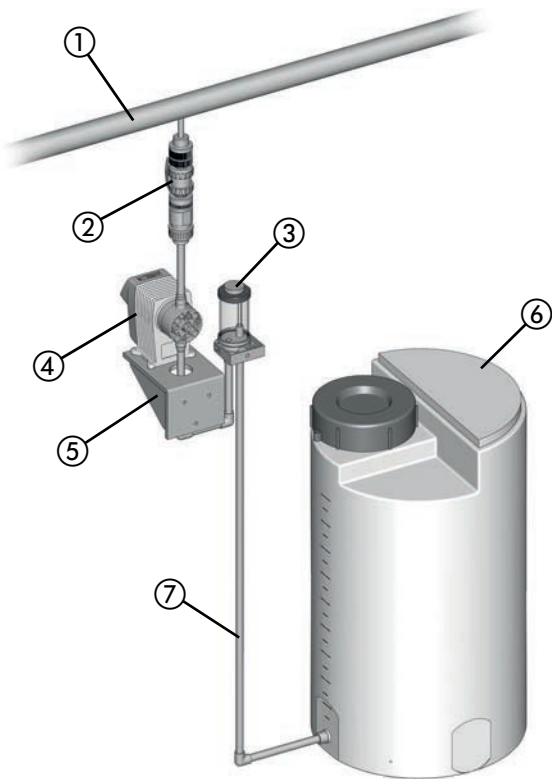

Fig. 8-15: Installation with a priming aid

No.	Description
①	Main line
②	Injection nozzle with shut-off valve
③	Priming aid
④	MAGDOS LP dosing pump
⑤	Wall bracket

Table 8-5: Designation of components

No.	Description
⑥	Chemical tank
⑦	Suction line

Table 8-5: Designation of components

8.7.8 Level monitoring

Level monitoring of suction-side feeding of the dosing medium to prevent the tank being sucked dry and to ensure that it can be topped up again in good time.

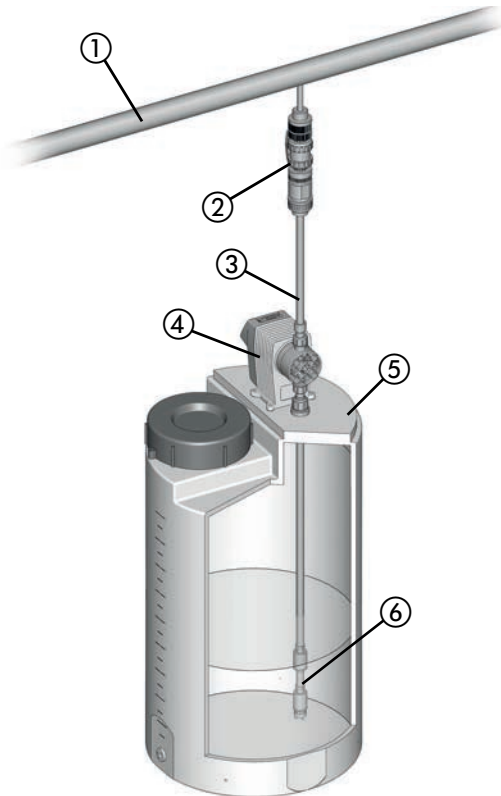

Fig. 8-16: Installation with a level monitoring system

No.	Description
①	Main line
②	Injection nozzle with shut-off valve
③	Pressure line
④	MAGDOS LP dosing pump
⑤	Chemical tank
⑥	Suction line with level monitoring

Table 8-6: Designation of components

8.7.9 Dosing of suspensions

When dosing suspensions, the dosing head must be rinsed regularly to prevent depositing. To do this, you install a feed line for the rinsing medium (water) in the suction side installation.

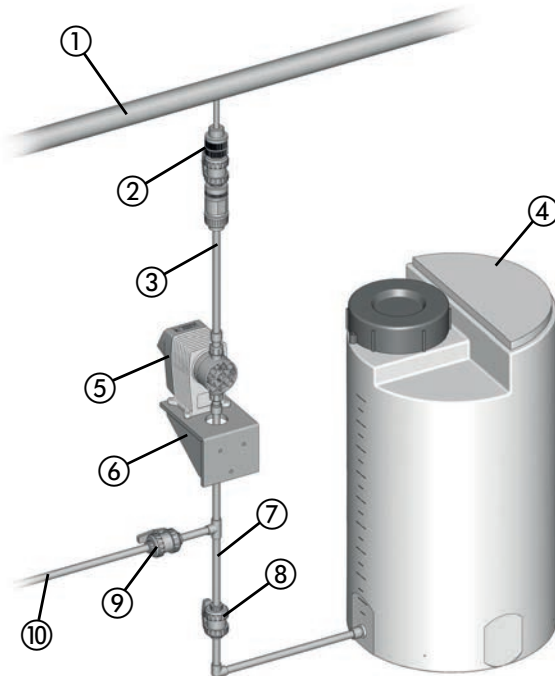

Fig. 8-17: Dosing of suspensions

No.	Description
①	Main line
②	Injection nozzle with shut-off valve
③	Pressure line
④	Chemical tank
⑤	MAGDOS LP dosing pump
⑥	Wall bracket
⑦	Suction line
⑧	Shutoff valve
⑨	Shutoff valve
⑩	Line for rinsing the dosing head

Table 8-7: Designation of components

8.7.10 Suction pressure regulator

A suction pressure regulator may be necessary if the suction-side installation of the system demonstrates a varying suction pressure or supply pressure:

- Dosing pumps that are installed above dosing tanks deliver less as the tank empties, since the suction head increases.
- Dosing pumps that are installed below dosing tanks deliver less as the tank empties, since the positive delivery pressure reduces.

Further problems that can occur:

- Greater wear on the dosing pump, e.g. diaphragm rupture due to the effects of heavy forces with particularly high tanks and high-density dosing media.
- Idling of the dosing tank in the case of a diaphragm rupture or pipe breakage.
- Impermissibly high forces in the pump transmission that occur when dosing pumps receive the dosing medium directly from the pressure line.
- Reduced performance or destruction of fittings due to cavitation with long suction lines.

Installing a suction pressure regulator is a remedy for the problems above. The suction pressure regulator is opened by the dosing pump's suction pressure. This ensures that no dosing medium can flow if the dosing pump is not running or no vacuum can be generated following a pipe fracture.

Notes on assembly:

- When using a large suction pressure regulator, you should provide a pulsation dampener on the suction side.

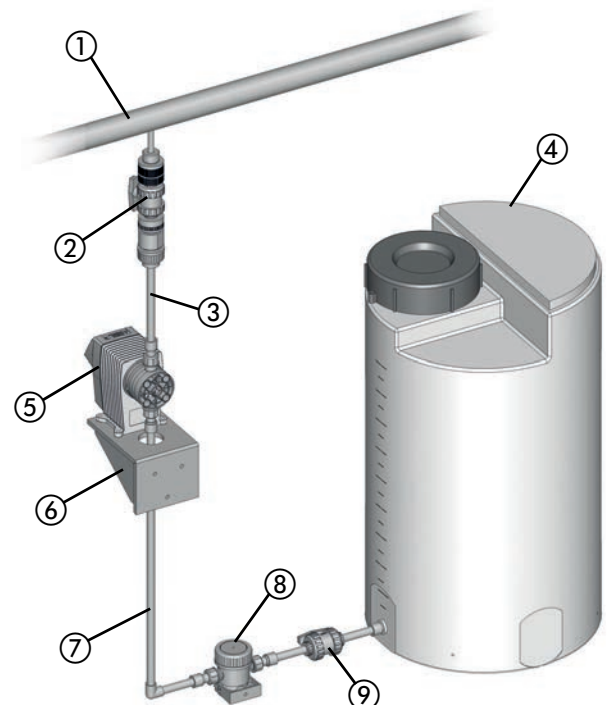

Fig. 8-18: Installation with a suction pressure regulator

No.	Description
①	Main line
②	Injection nozzle with shut-off valve
③	Pressure line
④	Chemical tank
⑤	MAGDOS LP dosing pump
⑥	Wall bracket
⑦	Suction line
⑧	Suction pressure regulator
⑨	Shutoff valve

Table 8-8: Designation of components

9 Electrical installation

DANGER

Danger to life due to electric shock!

If there is an electrical accident, you must disconnect the dosing pump from the mains as quickly as possible.

⇒ Install an emergency stop switch or integrate the dosing pump into the plant safety concept.

CAUTION

Danger of automatic start up!

The dosing pump does not have an ON/OFF switch and may start to pump as soon as it is connected to the mains supply. This means that dosing medium can escape. Depending on the type and hazardousness of the dosing medium, this can result in damage to property or to injury.

⇒ Install an emergency stop switch or integrate the dosing pump into the plant safety concept.

NOTICE

Damage due to wrong mains voltage

The dosing pump can be damaged if you connect it to the wrong mains voltage.

⇒ Observe the information on the mains supply that is given on the nameplate.

NOTICE

Insufficient electromagnetic compatibility

When you connect the dosing pump to a socket without an attached protective earth, it is not possible to guarantee the interference radiation and interference immunity according to EMC regulations.

⇒ Only connect the dosing pump to sockets with an attached protective earth.

9.1 Principles

- The dosing pump has a 110 - 240 V AC 50/60 Hz wide-range power supply unit
- The electrical connection comply with local regulations.
- The dosing pump must be plugged into a grounded power outlet.
- To avoid dosing errors at the end of the process, the dosing pump must be locked electrically.
- The dosing pump must not be operated by switching the mains voltage on or off.

- Signal cables must not be laid parallel to high-voltage current lines or mains cables. You must route supply and signal lines in separate channels. An angle of 90° is required at line crossings.

9.2 Description of connection sockets



Fig. 9-1: Connection sockets 1 - 5

Inputs	Connection socket
Release input	1
Pulse input	2
Analog input	2
Level input	3
Dosing control input	5
Diaphragm rupture input	5

Table 9-1: Inputs of the control unit

Outputs	Connection socket
Stroke feedback output	1
Alarm relay output	4

Table 9-2: Outputs of the control unit

9.2.1 Connection socket 1

9.2.1.1 Stroke feedback output

At the stroke feedback output, the dosing pump reports back each executed stroke to the pulse input of another dosing pump. In this way, it is possible to network several dosing pumps and to trigger synchronized dosing strokes.

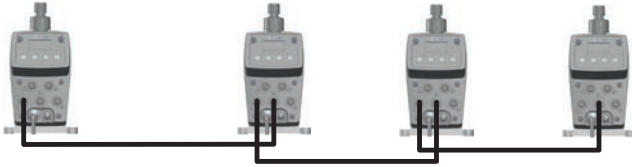

Fig. 9-2: Synchronization of several dosing pumps by means of stroke feedback and pulse control

- Optocoupler, max. 30 V DC, 5 mA
- Assignment of pin 1, 2

9.2.1.2 Release input

Using the Release input, it is possible to start or stop the dosing pump externally.

- Potential-free contact
- Programmable NC or NO contact
- Assignment of pin 3, 4

Pin	M12x1 (A-coded)	Assignments	Connection	Cable colour*	
1		Optocoupler collector (+)		Brown	BN
2		Optocoupler emitter (-)		White	WH
3		Ground (GND)		Blue	BU
4		External On/Off		Black	BK

Table 9-3: Connection socket 1

* Applies to cable colours of cables from Lutz-Jesco GmbH. No liability is accepted for cables from other manufacturers.

9.2.2 Connection socket 2

9.2.2.1 Analog input

The analog input makes it possible to control the delivery capacity by means of a 0/4 - 20 mA signal. The delivery capacity is regulated via the stroke frequency.

- 0/4 - 20 mA Signal
- Invertible
- Current range variable
- Working resistance: 150 Ohm

For information on setting the *Analog input* operating mode, see page 40.

9.2.2.2 Pulse input

The pulse input makes it possible to control the delivery capacity by means of pulses. The system regulates the delivery capacity by means of the dosing pump's stroke frequency and number of strokes in dependence on the number of pulses and the pulse spacing.

- Provided potential-free contact
- For potential-free NO contact, e.g. a contact-type water meter
- 5 V DC supply voltage (current across all connections limited to a total maximum of 50 mA)
- Pulse length min. 4 ms

For information on setting the *Pulse input* operating mode, see page 42.

Pin	M12x1 (A-coded)	Assignments	Connection	Cable colour*	
1		Pulses		Brown	BN
2		(+) 0/4 - 20 mA		White	WH
3		Ground (GND)		Blue	BU
4	-	+ 5 V DC		Black	BK

Table 9-4: Connection socket 2

* Applies to cable colours of cables from Lutz-Jesco GmbH. No liability is accepted for cables from other manufacturers.

9.2.3 Connection socket 3

9.2.3.1 Level input

Connection for level monitoring of a dosing tank (e.g. a suction line with a float switch).

- 5 V DC supply voltage (current across all connections limited to a total maximum of 50 mA)
- Alert and main alarm
- Potential-free contact
- Programmable NC or NO contact

For more details on installing the level monitoring system, see page 24.

For information on setting the *Level input* function, see page 33.



Pin	M12x1 (A-coded)	Assignments	Connection	Cable colour*	
1		Pre-alarm		Brown	BN
2		Main alarm		White	WH
3		Ground (GND)		Blue	BU
4	-	+ 5 V DC	-	Black	BK

Table 9-5: Connection socket 3

* Applies to cable colours of cables from Lutz-Jesco GmbH. No liability is accepted for cables from other manufacturers.

9.2.4 Connection socket 4

9.2.4.1 Alarm relay output

Using the alarm relay, it is possible to forward outwards disturbances on the dosing pump.

- Voltage-free changeover contact
- Max. 250 V AC, 2.5 A or max. 30 V DC, 2.5 A,

For information on setting the *Alarm relay*, see page 33.



Pin	M12x1 (B-coded)	Assignments	Connection	Cable colour*	
1		Break (NC) contact		Brown	BN
2		Make (NO) contact		White	WH
3		-		Blue	BU
4		Changeover contact		Black	BK

Table 9-6: Connection socket 4

* Applies to cable colours of cables from Lutz-Jesco GmbH. No liability is accepted for cables from other manufacturers.

9.2.5 Connection socket 5

9.2.5.1 Dosing control input

You can connect the FLOWCON flow-through sensor to this socket. The FLOWCON, which is available as an optional extra, allows you to monitor the dosing medium's flow motion after a dosing pump stroke.

- 5 V DC supply voltage (current across all connections limited to a total maximum of 50 mA)

For information on setting the *dosing control* function, see page 34.

9.2.5.2 Diaphragm rupture input

A connection to a leak sensor in the flange of the dosing head to monitor for a possible diaphragm rupture.

- 5 V DC supply voltage (current across all connections limited to a total maximum of 50 mA)

For more details on installing the leak sensor, see page 20.

For information on setting the *diaphragm rupture* function, see page 34.



Pin	M12x1 (A-coded)	Assignments	Connection	Cable colour*	
1		Flowcon	Flowcon:	Brown	BN
2		Leak sensor		White	WH
3		Ground (GND)	Leak sensor:		Blue
4	-	+ 5 V DC	-	Black	BK

Table 9-7: Connection socket 5

* Applies to cable colours of cables from Lutz-Jesco GmbH. No liability is accepted for cables from other manufacturers.

9.2.6 Ethernet connection socket (MAGDOS LP-Net only)



Fig. 9-3: Ethernet connection socket

The network connection socket makes it possible to control the stroke frequency and the number of strokes. In addition, it is possible to transmit in the opposite direction all the disturbance and status messages.

The dosing pump has a network input in the form of a 4-pole, D-coded M12x1 female connector. To make the typical Ethernet RJ-45 male connection, Lutz-Jesco GmbH offers different lengths of special twisted-pair network cables. If you use third-party cables, choose a Category 3 cable with an impedance of 100 Ohm or above.

- Modbus TCP/IP protocol
- 10 Mbps

For information on setting the *Network* operating mode, see page 47.

Pin	M12x1 (D-coded)	Assignments	Connection
1		TX+	Pair 1
2		RX+	Pair 2
3		TX-	Pair 1
4		RX-	Pair 2
-		Screen	-

Table 9-8: Ethernet connection socket

9.2.6.1 Installing a wired network

During installation, observe the following points:

- The Ethernet is cabled in a star topology. The maximum cable length is 100 m.
- You must route separately as a bundle the different categories of cables (e.g. power supply, data lines and sensitive lines for measuring purposes). In this connection, cables should cross at an angle of 90°.
- There must either be a minimum distance between the power cable and data lines of 10 cm or you must install a partition or route the data line in a metal pipe. If this is not possible, use separate cable support systems.
- Only use screened cables and plug-in connectors.
- Route copper wires outside cable support systems through plastic pipes.
- Temperatures that are too high or too low result in lower mechanical and electrical loading or lead to damage.
- Data lines must only be subjected to a defined tensile load; otherwise, the electrical or attenuation values can no longer be guaranteed.
- When pulling cables out of the cable drum, avoid looping or pulling over sharp edges.
- With copper wires, implement potential equalization; when doing this, differentiate between hazardous and non-hazardous areas.
- Electrical, magnetic and electromagnetic fields affect signal transmission and under some circumstances can destroy electronic components.

10 Control

10.1 Operator controls of the control unit

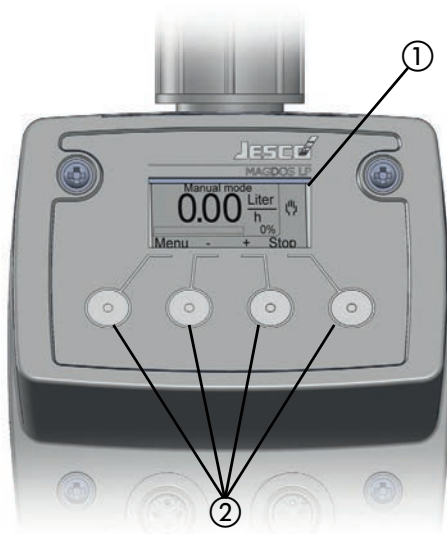

Fig. 10-1: Operator controls of the control unit

No.	Explanation
①	Graphic display
②	Four multifunction keys

Table 10-1: Operator controls of the control unit

You operate the MAGDOS LP dosing pump using the four multifunction keys below the display. The keys have different assignments depending on where you are located at any one time in the menu structure. The system shows the respective functions of the keys at the bottom of the display:

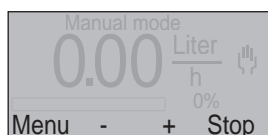

Fig. 10-2: Function assignments of the multifunction keys

In this example, the first key from the left has the **Menu** function; the second one has the **-** function; the third one has the **+** function and the fourth one has the **Stop** function.

The **+** and **-** selection keys as well as the **↑** and **↓** keys have a repeat function, i.e. if you keep them pressed down, the system automatically repeats the key function.

The display brightness reduces 45 seconds after your last input.

Two minutes after your last input, the control unit goes back to the start screen of the selected operating mode in each case.

i The dosing pump does not have an ON/OFF switch. After being disconnected from the power supply, the dosing pump starts in the operating mode and configuration that you selected last.

10.2 Explanation of menu navigation

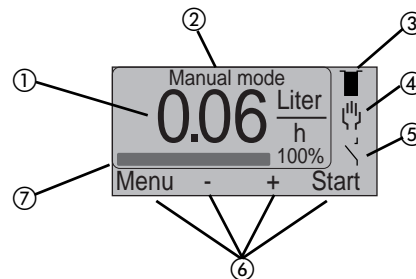

Fig. 10-3: Representation of the control unit on the display

No.	Explanation
①	Calculated delivery capacity (units per day or hour)
②	Designation of active operating mode
③	Symbol for level monitoring
④	Symbol for the active operating mode
⑤	Symbol for external ON/OFF
⑥	Variable assignment of the four menu keys on the dosing pump
⑦	Bar for representing the stroke frequency or delivery capacity

Table 10-2: Explanation of menu navigation

10.3 Explanation of the menu icons

10.3.1 Level monitoring

Symbol	Meaning
	Dosing tank full
	Dosing tank at minimum (alert)
	Dosing tank empty (main alarm)

Table 10-3: Explanation of the menu icons – Level monitoring

10.3.2 Operating modes

Symbol	Meaning
	Manual operation
	Analog input
	Pulse input

Table 10-4: Explanation of the menu icons – Operating modes

Symbol	Meaning
	Batch mode (interval/timer mode)
	Network mode (MAGDOS LP-Net only)

Table 10-4: Explanation of the menu icons – Operating modes

10.3.3 Release input

Symbol	Meaning
	Active and open
	Active and closed

Table 10-5: Explanation of the menu icons – Release input

10.4 Menu settings at initial commissioning

On first connecting the dosing pump to the mains or resetting it to the factory default setting, it is automatically in the *Language* menu (menu 6.3). The system prompts you to specify the menu language.

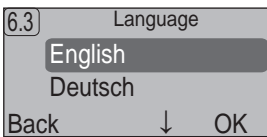

Fig. 10-4: Menu 6.3 Language

- Use the **↑** or **↓** key to choose a language.
- Press **OK**.
 - The dosing pump displays menu 6, *Setup system*.
- Press **Menu**.
 - The dosing pump displays menu 1 *Main menu*.
- Press **Back**.
 - The dosing pump displays the start screen. In the factory default setting, the *Manual mode* operating mode is preset and saved with a stroke frequency of 0 % (no dosing).

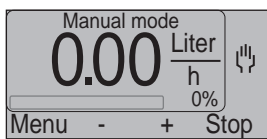

Fig. 10-5: Start screen of the dosing pump after initial commissioning

10.5 Main menu

- ➔ Press **Menu**.
 - The dosing pump displays menu 1 *Main menu*.

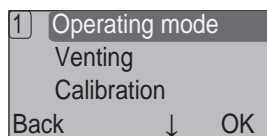

Fig. 10-6: Main menu

The main menu lists the main functions of the MAGDOS LP dosing pump:

- *Operating mode* (see “Operating modes” on page 40),
- *Venting* (see “Venting the dosing pump” on page 39),
- *Calibration* (see “Calibrating the dosing pump” on page 39),
- *System setup* (see “System setup” on page 32),
- *Info* (see “Information about the dosing pump” on page 37),
- *Messages* (see “Messages of the control unit” on page 37).



For a complete overview of the control unit's menu structure, see page 56.

10.6 System setup

In the *System setup* menu item, you configure all the dosing parameter's general parameters that do not depend on an operating mode.

- Press **Menu**.
- Use the **↑** or **↓** key to choose the *System setup* menu item and press **OK**.
 - The dosing pump displays the *System setup* menu.

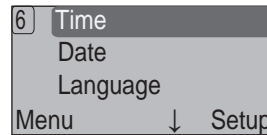

Fig. 10-7: System setup menu

10.6.1 Set "Time" menu item

- Use the **↑** or **↓** key to choose the *Time* menu item and press **Setup**.
- Use the **+** and **-** keys to set the desired hour and press **Next**.
- Use the **+** and **-** keys to set the desired minute.



If you keep the key pressed down, the dosing pump keeps incrementing the value by two hours or two minutes.

- Press **Back**.
 - ✓ **The time is set.**

10.6.2 Set "Date" menu item

1. Use the **↑** or **↓** key to choose the *Date* menu item and press **Setup**.
2. Use the **+** and **-** keys to set the desired day and press **Next**.
3. Use the **+** and **-** keys to set the desired month and press **Next**.
4. Use the **+** and **-** keys to set the desired year and press **Next**.
5. Use the **+** and **-** keys to set the desired day of the week.

 If you want to use the MAGDOS LP dosing pump's *Batch mode* function, you must set the correct day of the week.

6. Press **Back**.

✓ **The date is set.**

10.6.3 Set "Language" menu item

1. Use the **↑** or **↓** key to choose the *Language* menu item and press **Setup**.

You can choose from the following options:

- *English* (factory default setting),
- *Deutsch*,
- *Francais*,
- *Espanol*,
- *Portugues*,
- *Nederlands*,

2. Use the **↑** or **↓** key to choose a language and press **OK**.

✓ **The language is set.**

10.6.4 Set "Units" menu item

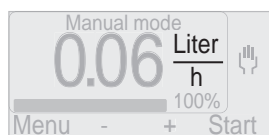

Fig. 10-8: Display of the unit of delivery capacity

1. Use the **↑** or **↓** key to choose the *Units* menu item and press **Setup**.

You can choose from the following units:

- Litres/Day,
- Litres/Hr.
- USgal/Day (American gallons),
- USgal/Hr. (American gallons),
- l.gal/Day (Imperial gallons),
- l. gal / Hr. (Imperial gallons),
- ml/Min.

2. Use the **↑** or **↓** key to choose the desired unit and press **OK**.

✓ **The unit is set.**

10.6.5 Set "Alarm relay" menu item

Using the alarm relay, it is possible to forward outwards disturbances on the dosing pump.

For information on the connection, see "Alarm relay output" on page 29.

1. Use the **↑** or **↓** key to choose the *Alarm relay* menu item and press **Setup**.

You can choose from the following options:

- *Not active* (factory default setting),
- *NO relay* (Normally open),
- *NC relay* (Normally closed).

2. Use the **↑** or **↓** key to choose the desired function and press **OK**.

✓ **The "alarm relay" is set.**

10.6.5.1 "Alarm relay" configuration

NC relay

Situation		Alarm relay output		Relay
Voltage supply	Fault	Pins 1/4	Pins 2/4	
No	No	closed	Open	inactive
	Yes	closed	Open	inactive
Yes	No	Open	closed	active
	Yes	closed	Open	inactive

Table 10-6: Configuration of NC relay

NO relay

Situation		Alarm relay output		Relay
Voltage supply	Fault	Pins 1/4	Pins 2/4	
No	No	closed	Open	inactive
	Yes	closed	Open	inactive
Yes	No	closed	Open	inactive
	Yes	Open	closed	active

Table 10-7: Configuration of NO relay

10.6.6 Set "Level input" menu item

Level monitoring of the dosing medium feed on the suction side with two alarm stages: Alert and main alarm

For more details on installing the level monitoring system, see "Level monitoring" on page 24.

For information on the connection, see "Level input" on page 29.

1. Use the **↑** or **↓** key to choose the *Level input* menu item and press **Setup**.

You can choose from the following options:

- *Not active* (factory default setting),
 - *Alarm = contact* (issues an alarm when the float contact is closed),
 - *Alarm = open* (issues an alarm when the float contact is open; setting for standard Lutz-Jesco GmbH level monitoring systems).
2. Use the **↑** or **↓** key to choose the desired function and press **OK**.
- ✓ **"Level input" is set.**

i The system displays the selected setting of the level input as an icon on the start screen of each operating mode. For an explanation of the icons, see page 31.

10.6.6.1 "Level input" configuration

Status	Display	Level input		Dosing pump
		Alarm = contact	Alarm = open	
Tank full				Running
Tank at minimum (alert)				Running
Tank empty (main alarm)				Stopped

Table 10-8: Level input configuration

10.6.7 Set "Diaphragm rupture" menu item

As an option, the MAGDOS LP dosing pump is supplied with a leak sensor in the diaphragm flange; in the case of a diaphragm rupture, the sensor passes on a signal to the dosing pump and stops it.

For more information, refer to "Diaphragm rupture sensor leak sensor" on page 20.

For information on the connection, see "Diaphragm rupture input" on page 29.

1. Use the **↑** or **↓** key to choose the *Diaphragm rupture* menu item and press **Set up**.

You can choose from the following options:

- *Not active* (factory default setting),

- *Alarm = contact* (issues an alarm if the sensor output is closed for five strokes; setting for standard Lutz-Jesco GmbH leak sensor),
- *Alarm = open* (issues an alarm if the sensor output is open for five strokes).

2. Use the **↑** or **↓** key to choose the desired function and press **OK**.

✓ **"Diaphragm rupture" is set.**

10.6.8 Set "Release input" menu item

Option of starting or stopping the dosing pump externally.

For information on the connection, see "Release input" on page 28.

For information on starting and stopping the dosing pump, see "External On/Off via Release input" on page 47.

1. Use the **↑** or **↓** key to choose the *Release input* menu item and press **Set up**.

You can choose from the following options:

- *Not active* (factory default setting),
- *Run = contact* (enables the dosing pump if both contacts are closed),
- *Run = open* (enables the dosing pump if both contacts are open).

2. Use the **↑** or **↓** key to choose the desired function and press **OK**.

✓ **"Release input" is set.**

i The system displays the selected setting of the Release input as an icon on the start screen of each operating mode. For an explanation of the icons, see page 32.

10.6.9 Set "Dosing control" menu item

The FLOWCON, which is available as an optional extra, allows you to monitor the dosing medium's flow motion after a dosing pump stroke.

For information on the connection, see "Dosing control input" on page 29.

1. Use the **↑** or **↓** key to choose the *Dosing control* menu item and press **Set up**.

- ▶ The dosing pump displays menu 6.9 *Dosing control*. *Not active* is preselected as the mode.

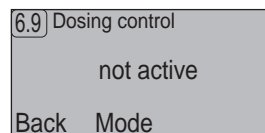

Fig. 10-9: Dosing control "not active"

2. Use **Mode** to activate the FLOWCON contact.

- ▶ The dosing pump is set to *Pump On* but continues to run in the case of FLOWCON error messages.

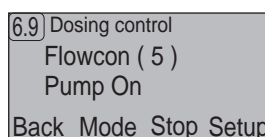

Fig. 10-10: Dosing control "Pump On"

3. Press **Stop**.
 - ▶ The dosing pump is set to *Pump Stop* and stops when an error message arrives.

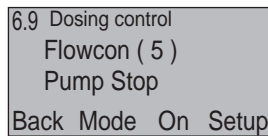

Fig. 10-11: Dosing control "Pump Stop"

4. Press **Setup** to set the *Faulty strokes*. The dosing pump's factory default setting is five strokes; this means that the system issues an error message after five faulty strokes.
 5. Use the **+** and **-** keys to set the desired value. Adjustment range: 0 - 100 faulty strokes.
 6. Press **OK**.
 7. Press **Back**.
- ✓ **"Dosing control" is set.**

10.6.10 Set "Release code" menu item

Protects menu 1 *Main menu* from unauthorized access. In the factory default setting, the code is not activated.

You can set any *Release code* you like from 0000 to 9999.

1. Use the **↑** or **↓** key to choose the *Release code* menu item and press **Setup**.
 - ▶ The dosing pump displays menu 6.10 *Release code*.

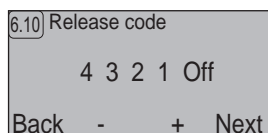

Fig. 10-12: Release code

2. Use the **+** and **-** keys to set a value of 0 to 9 for the first digit of the code and then press **Next**.
3. Proceed as described under point 2 for the other digits.
4. Choose the last item *Off* and press **+**.
5. Press **Back**.
 - ▶ The *Release code* is activated after 120 seconds. You must enter it when accessing the *Main menu*.

i After entering the correct *Release code* and exiting the *Main menu*, you must enter the code again when 120 seconds have elapsed and you access the *Main menu*.

10.6.10.1 Entering the Release code

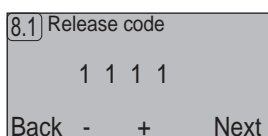

Fig. 10-13: Entering the Release code

1. Use the **+** and **-** keys to set a value of 0 to 9 for the first digit of the code and then press **Next**.
2. Proceed as described under point 1 for the other digits.
3. After entering all the digits, press **OK**.
 - ▶ If your input is correct, the dosing pump displays the *Main menu*.

i Should you have forgotten the code, please contact Lutz-Jesco GmbH.

10.6.10.2 Deactivating the Release code

1. Press **Menu**.
2. Enter the correct release code and press **OK**.
3. Use the **↑** or **↓** key to choose the *System setup* menu item and press **OK**.
4. Use the **↑** or **↓** key to choose the *Release code* menu item and press **Setup**.
5. Keep pressing **Next** until *On* is selected.
6. Press **-**.
7. Press **Back**.

✓ **Release code deactivated.**

10.6.11 Set "Safety code" menu item

Protects the *System setup* menu from unauthorized access. In the factory default setting, the code is not activated.

You can set any *Safety code* you like from 0000 to 9999.

1. Use the **↑** or **↓** key to choose the *Safety code* menu item and press **Setup**.
 - ▶ The dosing pump displays menu 6.11 *Safety code*.

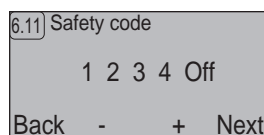

Fig. 10-14: Safety code

2. Use the **+** and **-** keys to set a value of 0 to 9 for the first digit of the code and then press **Next**.
3. Proceed as described under point 2 for the other digits.
4. Choose the last item *Off* and press **+**.
5. Press **Back**.
 - ▶ The *safety code* is activated after 120 seconds. You must enter it when accessing the *System setup* menu.

i After entering the correct *safety code* and exiting the *System setup* menu, you must enter the code again when 120 seconds have elapsed and you access the *System setup* menu.

10.6.11.1 Entering the safety code

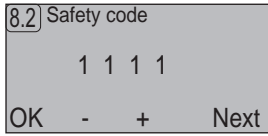



Fig. 10-15: Entering the safety code

1. Use the **+** and **-** keys to set a value of 0 to 9 for the first digit of the code and then press **Next**.
2. Proceed as described under point 1 for the other digits.
3. After entering all the digits, press **OK**.
 - ▶ If your input is correct, the dosing pump displays the *System setup* menu.

 Should you have forgotten the code, please contact Lutz-Jesco GmbH.

10.6.11.2 Deactivating the safety code

1. Press **Menu**.
2. Use the **↑** or **↓** key to choose the *System setup* menu item and press **OK**.
3. Enter the correct safety code and press **OK**.
4. Use the **↑** or **↓** key to choose the *Safety code* menu item and press **Setup**.
5. Keep pressing **Next** until *On* is selected.
6. Press **-**.
7. Press **Back**.

✓ **The safety code is deactivated.**

10.6.12 Set "Factory setup" menu item

Resets the dosing pump's control unit settings to the factory default setting.

1. Use the **↑** or **↓** key to choose the *Factory setup* menu item and press **Setup**.
2. Press **OK**.
 - ▶ The dosing pump displays the *Language* menu (menu 6.3); see also "Menu settings at initial commissioning" on page 32.

✓ **The dosing pump is reset to the factory setup setting.**

10.6.13 Set "Eco-Mode" menu item

Setting energy-saving mode. Doing this changes the power consumption, the delivery capacity and the delivery pressure; see also "Technical Data" on page 12.

1. Use the **↑** or **↓** key to choose the *Eco-Mode* menu item and press **Setup**.

You can choose from the following options:

- *Off* (factory default setting),
 - *Eco-Mode 1*,
 - *Eco-Mode 2*,
2. Use the **↑** or **↓** key to choose the desired function and press **OK**.
 - ▶ The system displays the selected *Eco-Mode* on the start screen after the respective operating mode.

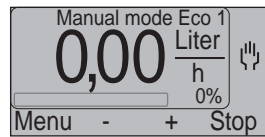

Fig. 10-16: Display of Eco-Mode 1 in manual operating mode

10.6.14 Set "User setup" menu item

This menu item allows you to save the settings you made in the *System setup* menu.

10.6.14.1 Saving own settings

1. Use the **↑** or **↓** key to choose the *User setup* menu item and press **Setup**.
2. Use the **↑** or **↓** to choose *Save* and press **OK**.

✓ **Own settings saved.**

10.6.14.2 Loading own settings

1. Use the **↑** or **↓** key to choose the *User setup* menu item and press **Setup**.
2. Use the **↑** or **↓** to choose *Load* and press **OK**.

✓ **Own settings loaded.**

10.6.15 Set "IP address" menu item (MAGDOS LP-Net only)

This menu item allows you to set the network address. Your local network administrator specifies the address. It is not possible to set up a subnet, a proxy or a gateway.

1. Use the **↑** or **↓** key to choose the *IP address* menu item and press **Setup**.
2. Use the **+** and **-** keys to set a value of 001 to 255 for the first digit of the IP address and then press **Next**.
3. Proceed as described under point 2 for the other digits of the IP address.
4. Press **Back**.

✓ **IP address is set.**

10.7 Information about the dosing pump

In the *Info* menu item, you can find a wide range of information about your dosing pump.

1. Press **Menu**.
2. Use the **↑** or **↓** key to choose the *Info* menu item and press **OK**.
 - ▶ The dosing pump displays menu 7.1 *Info 1*.

7.1	Info 1	
	Strokes / min	180
	Capacity	3.80 l/Std
	Calibration	3.80 l/Std
	Menu	Next

Fig. 10-17: Display of menu Info 1

3. Keep pressing **Next** to get to subsequent *Info* menus.

The *Info* menus display the following information:

Menu	Information
<i>Info 1</i>	<ul style="list-style-type: none"> ■ Maximum strokes/minute ■ Maximum delivery capacity in l/hr ■ Calibrated delivery capacity in l/hr
<i>Info 2</i>	<ul style="list-style-type: none"> ■ Stroke volume at factory setting in ml ■ Stroke volume after calibration in ml
<i>Info 3</i>	<ul style="list-style-type: none"> ■ Running time of the dosing pump in hrs. ■ Total strokes of the dosing pump carried out
<i>Info 4</i>	<ul style="list-style-type: none"> ■ Software version and date of updating ■ Part number ■ Serial number
<i>Info 5</i>	<ul style="list-style-type: none"> ■ Current value in mA at analog input ■ Date and time
<i>Info 6</i> (MAGDOS LP-Net only)	<ul style="list-style-type: none"> ■ MAC number ■ IP number
<i>Info 7</i>	Assignment of connection socket 1
<i>Info 8</i>	Assignment of connection socket 2
<i>Info 9</i>	Assignment of connection sockets 2 and 3
<i>Info 10</i>	Assignment of connection socket 4
<i>Info 11</i>	Assignment of connection socket 5

Table 10-9: Explanation of the *Info* menus

4. Press **Menu** to exit the *Info* menu.

10.8 Messages of the control unit

The system logs the disturbance messages of the dosing pump with the date, time and error code.

Refer to „Troubleshooting“ > „List of control unit messages“ (Page 53) for a list of all the disturbance messages and their meanings.

10	Messages	14:39:50
	01.02.2012 - 14.32 #09	▶
	Manual Stop	
	Menu	↑ ↓ Delete

Fig. 10-18: Display of disturbance messages

The following symbols are used:

Symbol	Meaning
!	Symbol for an event
▶	Symbol for the start of a message
▶	Symbol for the end of a message

Table 10-10: Explanation of the menu icons – disturbance messages

1. Press **Menu**.
2. Use the **↑** or **↓** key to choose the *Messages* menu item and press **OK**.
3. Keep pressing **↑** or **↓** to display the disturbance messages that are listed in chronological order.
4. Press **Menu** to exit the *Messages* menu.

10.8.1 Deleting the messages of the control unit

1. Press **Menu**.
2. Use the **↑** or **↓** key to choose the *Messages* menu item and press **OK**.
3. Press **Back**.
4. Press **Back**.

✓ **The messages of the control unit are deleted**

11 Operation

	WARNING
<p>Caustic burns or other burns through dosing media!</p> <p>After connecting the mains supply, residual dosing media in the dosing head can spray out.</p> <ul style="list-style-type: none"> ⇒ Before connecting the mains supply, connect the dosing lines. ⇒ Check that all the screw connections have been tightened correctly and are leak-proof. 	

	WARNING
<p>Caustic burns or other burns through dosing media!</p> <p>While working on the dosing head, valves and connections, you may come into contact with dosing media.</p> <ul style="list-style-type: none"> ⇒ Use sufficient personal protective equipment. ⇒ Rinse the dosing pump with a liquid (e.g. water) which does not pose any risk. Ensure that the liquid is compatible with the dosing medium. ⇒ Release pressure in hydraulic parts. ⇒ Never look into open ends of plugged pipelines and valves. 	

	CAUTION
<p>Danger of personal injury and material damage!</p> <p>Dosing medium can escape if you loosen connections on the dosing head, e.g. for venting, during operation.</p> <ul style="list-style-type: none"> ⇒ Follow the safety data sheet of the dosing medium. ⇒ Clean the dosing pump if dosing medium escapes. ⇒ Dispose of the dosing medium correctly. 	

	CAUTION
<p>Increased risk of accidents due to insufficient qualification of personnel!</p> <p>Dosing pumps and their accessories may only be installed, operated and maintained by personnel with sufficient qualifications. Insufficient qualification will raise the risk of accidents.</p> <ul style="list-style-type: none"> ⇒ Ensure that all action is taken only by personnel with sufficient and corresponding qualifications. ⇒ Prevent access to the system for unauthorised persons. 	

	CAUTION
<p>Danger of personal injury and material damage!</p> <p>Changing dosing media can lead to unpredictable reactions.</p> <ul style="list-style-type: none"> ⇒ Thoroughly clean the dosing pump and appropriate sections of the plant avoid chemical reactions. 	

	CAUTION
<p>Danger of automatic start up!</p> <p>The dosing pump does not have an ON/OFF switch and may start to pump as soon as it is connected to the mains supply. This means that dosing medium can escape. Depending on the type and hazardness of the dosing medium, this can result in injury.</p> <ul style="list-style-type: none"> ⇒ Stop the dosing pump before disconnecting it from the mains supply. ⇒ Ensure that the dosing pump has been installed correctly before connecting it to the mains supply. 	

11.1 Commissioning the dosing pump

Precondition for action:

- ✓ The dosing pump has been assembled and installed in accordance with Section "Installing the Dosing Pump" (see page 15), Section "Hydraulic installation" (see page 16) and Section "Electrical installation" (see page 27).
- ✓ All the mechanical fastenings have been inspected to ensure adequate load-bearing capacity.
- ✓ The dosing head screws have been tightened with the correct torque (see "Tighten dosing head bolts" on page 50).
- ✓ All the hydraulic sections have been inspected to ensure they are adequately leak-proof and that the through flow direction is correct.
- ✓ The dosing pump has been set in accordance with "Menu settings at initial commissioning" (see page 32) and, if necessary, the other settings in menu "System setup" (see page 32) have been carried out.
- ✓ Personnel have read all the operating instructions and understood them completely.

	<p>For initial commissioning, it is advisable to use water as the dosing medium to check that the system is leak-proof and that the dosing pump is functioning correctly. Check first whether undesirable reactions could occur between the actual dosing medium and the water.</p>
--	---

Perform the following working steps:

1. Open the shut-off valves on the suction and discharge sides if present.
2. Plug in the dosing pump's mains plug to the power supply.
3. Vent the dosing pump, (see "Venting the dosing pump" on page 39).
4. Calibrate the dosing pump (see "Calibrating the dosing pump" on page 39).
5. Select an operating mode and start the dosing pump in accordance with the instructions in the chapter entitled "Operating modes" (see page 40).
 - ▶ The dosing pump primes. if it does not prime enough, use a priming aid, (see "Priming aid" on page 24).

i At initial commissioning, it is advisable to prime the pump without backpressure. For this purpose, we recommend installing a relief valve on the discharge side of the dosing pump.

✓ **The dosing pump is commissioned.**

11.1.1 Venting the dosing pump

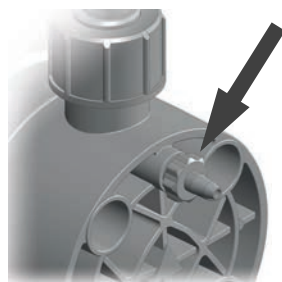

Fig. 11-1: Dosing head venting facility with vent screw

Precondition for action:

- ✓ The dosing head venting facility connected has been connected in accordance with the chapter entitled "Connecting the dosing head venting facility" (see page 19).

Perform the following working steps:

1. Open the vent screw by one complete turn (looking onto the dosing head, anti-clockwise).
2. Press **Menu**.
3. Use the **↑** or **↓** key to choose the *Venting* menu item and press **OK**.
4. Press the **Start** key and keep it pressed.
 - ▶ The dosing pump starts delivery at the highest stroke frequency.
5. Release **Start** key as soon as there is a continuous throughflow from the dosing head venting facility with no air bubbles.
 - ▶ The dosing pump stops delivery.
6. Close the vent screw.

✓ **The dosing pump is vented.**

i If you are using effervescent media, allow them to flow out continuously. Open the vent screw such that about one drop per 1- 3 strokes escapes.

11.1.2 Calibrating the dosing pump

In dependence on the dosing medium you are using and the existing delivery pressure, you must match the theoretical delivery capacity with that which is actually measured. You use the *Calibration* function to do this.

Precondition for action:

- ✓ The plant sections on the discharge side of the dosing pump have been installed correctly and are ready for operation.

Perform the following working steps:

1. Fill the metering container with the dosing medium.
2. Hold the end of the dosing pump's suction line in the metering container.
3. Vent the dosing pump, (see "Venting the dosing pump" on page 39).
4. Press **Menu**.
5. Use the **↑** or **↓** key to choose the *Calibration* menu item and press **OK**.
 - ▶ The dosing pump displays menu 5 *Calibration*.

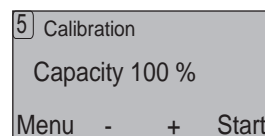

Fig. 11-2: Menu 5 Calibration

6. Use the **+** and **-** keys to set the percentage value of the delivery capacity with which you want to carry out calibration. Setting range 10 % - 100 %.
7. Press **Start**.
 - ▶ The dosing pump starts delivery and displays the number of executed strokes.
8. Press **Finish** as soon as you have achieved a measurable value in the metering container.
 - ▶ The dosing pump stops and displays the theoretical value of the delivery rate in ml.

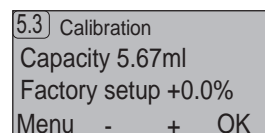

Fig. 11-3: Menu 5.3 Calibration

9. Read off the actual delivery rate from the metering container and use the **+** and **-** keys to correct the displayed delivery capacity. Adjustment range: -50 % - +50 %.
10. Press **OK**.

✓ **The dosing pump is calibrated.**

11.2 Operating modes

The MAGDOS LP dosing pump offers the following operating modes:

- *Manual operation* - Manual setting of the delivery capacity,
- *Analog input* - Controlling the delivery capacity by means of a 0/4 - 20 mA signal,
- *Pulse input* - Controlling the stroke frequency and number of strokes in dependence on the number of pulses and the pulse spacing,
- *Batch mode* - Controlling the delivery capacity and the delivery rate by means of manual starting, an external pulse at intervals or specified times in different modes,
- *Network mode* (MAGDOS LP-Net only) - Controlling the stroke frequency and number of strokes across a network.

11.2.1 Manual mode

CAUTION

Danger of automatic start up!

If the dosing pump is in manual mode with a specified stroke frequency, it retains the stroke frequency even after you disconnect it from the mains and then reconnect it. This means that dosing medium can escape. Depending on the type and hazardousness of the dosing medium, this can result in injury.

⇒ Stop the dosing pump before disconnecting it from the mains supply.

⇒ Ensure that the dosing pump has been installed correctly before connecting it to the mains supply.

11.2.1.1 Selecting the operating mode

1. Press **Menu**.
2. Use the **↑** or **↓** key to choose the *Operating mode* menu item and press **OK**.
3. Use the **↑** or **↓** key to choose the *Manual operation* menu item and press **OK**.
 - ▶ The dosing pump displays the start screen of *Manual operation* mode.

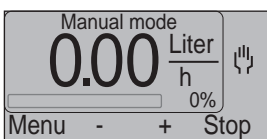

Fig. 11-4: Start screen of Manual operation

11.2.1.2 Starting the dosing pump

1. Press the **+** key to increase the stroke frequency by 1 %.
 - ▶ The dosing pumps starts dosing immediately. The system automatically calculates the resulting delivery capacity and displays it.
 2. Use the **+** and **-** keys to set the desired stroke frequency.
- ✓ **Dosing pump has started.**

11.2.1.3 Stopping the dosing pump

- ➔ Press **Stop**.
 - ▶ The system displays the "Stop" signal and **Stop** changes to **Start**. Press **Start** to restart the dosing pump.
- ✓ **Dosing pump has stopped.**

Pressing **Menu** does not interrupt dosing!
You do not stop the dosing pump until you change to a different operating mode using the menu.

11.2.2 Analog input

In *Analog input* operating mode, an external 0/4 - 20 mA signal, which is connected to the analogue input (see "Connection socket 2" on page 28) controls the stroke frequency.

11.2.2.1 Selecting the operating mode

1. Press **Menu**.
2. Use the **↑** or **↓** key to choose the *Operating mode* menu item and press **OK**.
3. Use the **↑** or **↓** key to choose the *Analog input* menu item and press **OK**.
 - ▶ The dosing pump displays the current configuration of this operating mode's parameters (Menu 3.21).

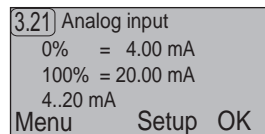

Fig. 11-5: Parameters of the operating mode

4. Press **OK**.
 - ▶ The dosing pump displays the start screen of *Analog input* mode.

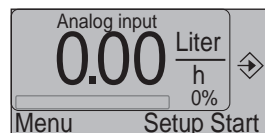

Fig. 11-6: Start screen of Analog input

11.2.2.2 Setting the signal mode

You have the option of setting a 0 - 20 mA signal or a 4 - 20 mA one.

1. Press **Setup**.
 - ▶ The dosing pump displays the current configuration of this operating mode's parameters (Menu 3.21).
2. Press **Setup**.
3. Use the **↑** or **↓** key to choose the *0/4..20mA* menu item and press **Setup**.
4. Press **Mode** to set 0 - 20 mA or 4 - 20 mA.
5. Press **OK**.
 - ▶ The dosing pump displays the current configuration of this operating mode's parameters (Menu 3.21).

6. Press **OK**.
 - ▶ The dosing pump displays the start screen of *Analog input* mode.

✓ **The signal mode is set.**

11.2.2.3 Setting the current value for 0 % delivery capacity

1. Press **Setup**.
 - ▶ The dosing pump displays the current configuration of this operating mode's parameters (Menu 3.21).
2. Press **Setup**.
3. Use the **↑** or **↓** key to choose the *0% current* menu item and press **Setup**.
4. Use the **+** and **-** keys to set the desired current value. Admissible values are in the range 0.00 - 20.00 mA. The value that is displayed in brackets indicates the actual connected current value.
5. Press **OK**.
 - ▶ The dosing pump displays the current configuration of this operating mode's parameters (Menu 3.21).
6. Press **OK**.
 - ▶ The dosing pump displays the start screen of *Analog input* mode.

✓ **The current value for 0 % delivery capacity is set.**

11.2.2.4 Setting the current value for 100 % delivery capacity

1. Press **Setup**.
 - ▶ The dosing pump displays the current configuration of this operating mode's parameters (Menu 3.21).
2. Press **Setup**.
3. Use the **↑** or **↓** key to choose the *100% current* menu item and press **Setup**.
4. Use the **+** and **-** keys to set the desired current value. Admissible values are in the range 0.00 - 20.00 mA. The value that is displayed in brackets indicates the actual connected current value.
5. Press **OK**.
 - ▶ The dosing pump displays the current configuration of this operating mode's parameters (Menu 3.21).
6. Press **OK**.
 - ▶ The dosing pump displays the start screen of *Analog input* mode.

 To process a 20 - 4 mA (inverted) analogue signal, you must configure parameter *0% current* to 20 mA and parameter *100% current* to 4 mA.

✓ **The current value for 100 % delivery capacity is set.**

11.2.2.5 Starting the dosing pump

Precondition for action:

- ✓ The dosing pump has been connected in accordance with the chapter entitled Section "Analog input" (see page 28).
1. Press **Start**.
 2. Apply a 0 - 20 mA or a 4 - 20 mA signal to the dosing pump's analog input.
 - ▶ The dosing pumps starts dosing immediately. The system automatically calculates the resulting delivery capacity and displays it.

✓ **Dosing pump has started.**

11.2.2.6 Stopping the dosing pump

- ➔ Press **Stop** or reduce the incoming signal to the value for *0% current* or less.

 If the signal value is below 4 mA with a 4 - 20 mA signal, the system issues an "Analog input error" message.

✓ **Dosing pump has stopped.**

11.2.3 Pulse input

In the *Pulse input* operating mode, the system regulates the stroke frequency and the number of strokes in dependence on the number of pulses and the pulse spacing of the pulse signal that is connected at the pulse input (see "Connection socket 2" on page 28).

11.2.3.1 Selecting the operating mode

1. Press **Menu**.
2. Use the **↑** or **↓** key to choose the *Operating mode* menu item and press **OK**.
3. Use the **↑** or **↓** key to choose the *Pulse input* menu item and press **OK**.
 - ▶ The dosing pump displays the current configuration of this operating mode's parameters (Menu 3.31).

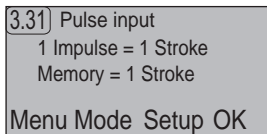

Fig. 11-7: Parameters of the operating mode

4. Press **OK**.
 - ▶ The dosing pump displays the start screen of *Pulse input* mode.

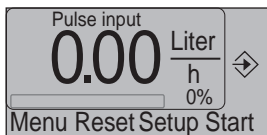

Fig. 11-8: Start screen of Pulse input

11.2.3.2 Choosing the pulse input mode

You can choose from the following modes in *Pulse input* operating mode:

Mode	Explanation
<i>Strokes</i>	Transmission and reduction of the number of pulses compared to the number of strokes
<i>Output</i>	Delivery of a fixed output per pulse
<i>Water meter</i>	Operation on a contact-type water meter

Table 11-1: Explanation of pulse input modes

The system marks the currently active mode by displaying *(On)* after the menu item. In the factory default setting, the *Strokes* mode is preselected: *Strokes (On)*.

1. Press **Setup**.
 - ▶ The dosing pump displays the current configuration of this operating mode's parameters (Menu 3.31).
2. Press **Mode**.
3. Use the **↑** or **↓** key to choose a Mode and press **OK**.
 - ▶ The dosing pump displays the current configuration of this operating mode's parameters (Menu 3.31).

4. Press **OK**.
 - ▶ The dosing pump displays the start screen of *Pulse input* mode.

11.2.3.3 Pulse input modes

The parameters that you can set are different depending on the mode.

Strokes

The *Strokes* pulse input mode offers the following configuration options:

Parameter	Explanation
<i>strokes / pulse</i>	Specifies the required number of strokes that the dosing pump carries out per pulse. In this connection, the system determines the stroke frequency on a dynamic basis based on the time between the last two pulses. Stroke frequency = number of strokes/pulse spacing Default settings: 1 stroke Adjustment range: 1 - 999 strokes.
<i>pulses / stroke</i>	Specifies the required number of pulses that must be connected to the input to trigger a stroke. Default setting: 1 pulse Adjustment range: 1 - 999 pulses.
<i>Stroke buffer</i>	The strokes that have still to be executed are saved in the stroke buffer. If stroke multiplication is set, the system writes all the strokes belonging to one pulse into the stroke buffer. With each pulse, the number of strokes in the accumulator increases; with each executed stroke, it decreases. The limit of the stroke buffer must be raised to save pulse requests that arrive during execution of the strokes from the previous pulse request. If the number of requested strokes exceeds the stroke buffer capacity, the system issues a "Stroke buffer maximum" message. Default setting: 1 stroke Adjustment range: 1 - 999 strokes.

Table 11-2: Strokes configuration Mode

In the case of pulse multiplication, you must increment the stroke buffer manually. Otherwise, you can confirm the configuration by pressing **OK**.

You can configure parameters *strokes / pulse* and *pulses / stroke* at the same time to define an exact number of strokes for a number of pulses. In this connection, the system determines the stroke frequency on a dynamic basis based on the time between the last two pulses.

Example:

If you set "7 strokes / pulse" and "3 pulses / stroke", the dosing pump carries out 7 strokes per 3 input pulses.

Output

The *Output* pulse input mode offers the following configuration options:

Parameter	Explanation
<i>Output</i>	Specifies the required output per pulse in ml. The output is calculated from the dosing pump's stroke volume after calibration and the automatically calculated ratio of the number of strokes to the number of pulses. The value that is displayed in brackets indicates the number of strokes and pulses (number of strokes/number of pulses).
<i>Stroke buffer</i>	See "Stroke buffer" mode under "Strokes" on page 42.

Table 11-3: Output configuration mode



The delivery capacity depends on the dosing pump's delivery pressure. To display the delivery capacity correctly, you must calibrate the dosing pump, see Page 39.

Water meter

The *Water meter* pulse input mode offers the following configuration options:

Parameter	Explanation
<i>Output</i>	Specifies the delivered output of the dosing pump per cubic metre (m ³) throughflow of the water meter in ml. The value corresponds to the throughflow amount per pulse. Since the dosing pump only controls the output via the stroke frequency, you must set the cycle between the water meter pulse and the dosing pump's stroke. The value that is displayed in brackets indicates the number of strokes that must be triggered per number of water meter pulses. (Number of strokes/number of pulses).
<i>Stroke buffer</i>	See "Stroke buffer" mode under "Strokes" on page 42.
<i>ml/pulse</i>	Specifies the water meter's throughflow amount per pulse in ml.
<i>l/Imp.</i>	Specifies the water meter's throughflow amount per pulse in l.
<i>m3/pulse</i>	Specifies the water meter's throughflow amount per pulse in m ³ .
<i>Maximum</i>	Specifies the water meter's maximum throughflow amount in m ³ /hr.

Table 11-4: Water meter configuration mode

On the basis of the water meter's values (*ml/pulse*, *l/pulse* or *m3/pulse*) and the delivered dosing capacity (output), the dosing pump automatically determines the stroke frequency. If the dosing pump's maximum output is exceeded during a fast sequence of pulses, the system issues a warning message.



If you enter contradictory parameters, the system displays this when you try to save them (Menu 3.41). It is not possible to activate the operating mode without correcting the parameters.

11.2.3.4 Configuring the pulse input mode

- Press **Setup**.
 - The dosing pump displays the current configuration of this operating mode's parameters (Menu 3.31).
- Press **Setup**.
- Use the **↑** or **↓** key to choose a parameter of the mode and press **OK**.
- Press the **+** key to increment the parameter's value or the **-** key to decrement it.
- Press **OK**.
 - The dosing pump displays the current configuration of this operating mode's parameters (Menu 3.31).
- Press **OK**.
 - The dosing pump displays the start screen of *Pulse input* mode.

11.2.3.5 Starting the dosing pump

Precondition for action:

- ✓ The dosing pump has been connected in accordance with the chapter entitled Section "Pulse input" (see page 28).
- Press **Start**.
 - Supply a pulse to the pulse input of the dosing pump.
 - ▶ The dosing pumps starts dosing immediately. The system automatically calculates the resulting delivery capacity and displays it.
- ✓ **Dosing pump has started.**

11.2.3.6 Stopping the dosing pump

- ➔ Press **Stop**.
- ✓ **Dosing pump has stopped.**

11.2.3.7 Clearing the stroke buffer

- ➔ Press **Reset**.
 - ▶ All the strokes in the accumulator that are still pending are deleted. The dosing pump stops; however, it is still active and waiting for the next pulse.
- ✓ **The stroke buffer has been cleared.**

11.2.4 Batch mode

In *Batch mode*, the system regulates the dosing pump's stroke frequency and the number of strokes in dependence on the delivered output. You can set the output on an individual basis for the dosing pump's run time, number of strokes and delivery capacity (stroke frequency),

It is started either manually or via a pulse signal applied at the pulse input (see "Connection socket 2" on page 28).

Dosing is possible at intervals or at specified times in the course of a week.

11.2.4.1 Selecting the operating mode

1. Press **Menu**.
2. Use the **↑** or **↓** key to choose the *Operating mode* menu item and press **OK**.
3. Use the **↑** or **↓** key to choose the *Batch mode* menu item and press **OK**.
 - ▶ The dosing pump displays the current configuration of this operating mode's parameters (Menu 3.41).

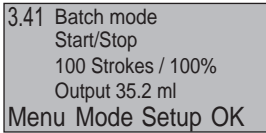

Fig. 11-9: Parameters of the operating mode

4. Press **OK**.
 - ▶ The dosing pump displays the start screen of *Batch mode*.

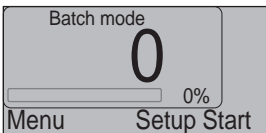

Fig. 11-10: Start screen of Batch mode

11.2.4.2 Choosing the batch mode mode

You can choose from the following modes in *Batch mode*:

Mode	Explanation
<i>Start/Stop</i>	Manual starting of dosing
<i>Ext. Start</i>	External starting of dosing
<i>Interval</i>	Automatic starting of dosing at regular intervals
<i>Timer</i>	Starting of dosing at a specific time

Table 11-5: Explanation of batch mode modes

The system marks the currently active mode by displaying *(On)* after the menu item. In the factory default setting, the *Start/Stop* mode is preselected: *Start/Stop (On)*.

1. Press **Setup**.
 - ▶ The dosing pump displays the current configuration of this operating mode's parameters (Menu 3.41).
2. Press **Mode**.
3. Use the **↑** or **↓** key to choose a Mode and press **OK**.
 - ▶ The dosing pump displays the current configuration of this operating mode's parameters (Menu 3.41).
4. Press **OK**.
 - ▶ The dosing pump displays the start screen of *Pulse input* mode.

11.2.4.3 Batch mode modes

The parameters that you can set are different depending on the mode.

Start/Stop and Ext. Start

The *Start/Stop* and *Ext. Start* batch modes do not differ in terms of the configuration; the only difference is in the way in which the dosing pump is started (see "Starting the dosing pump" on page 46). They offer the following configuration options:

Parameter	Explanation
<i>Runtime</i>	Specifies the required runtime of the dosing pump; input in minutes. The value that is displayed in brackets indicates the calculated output.
<i>No. of strokes</i>	Specifies the number of required strokes. The value that is displayed in brackets indicates the calculated output.
<i>Capacity</i>	Specifies the required stroke frequency stated as a percentage of the maximum stroke frequency (see "Delivery capacity data" on page 12).

Table 11-6: Start/Stop and Ext. configuration Start

Interval

The *Interval* batch mode mode offers the following configuration options:

Parameter	Explanation
<i>Runtime</i>	Specifies the required runtime of the dosing pump; input in minutes. The value that is displayed in brackets indicates the calculated output.
<i>No. of strokes</i>	Specifies the number of required strokes. The value that is displayed in brackets indicates the calculated output.
<i>Capacity</i>	Specifies the required stroke frequency stated as a percentage of the maximum stroke frequency (see "Delivery capacity data" on page 12).
<i>Interval</i>	Specifies the interval at which dosing is to take place on a regular basis. The interval cannot be shorter than the specified or calculated runtime; if necessary, the system corrects it automatically to the minimum value.

Table 11-7: Interval configuration mode

The system displays the *Interval* with a clock icon and the time elapsing until the start of next dosing.

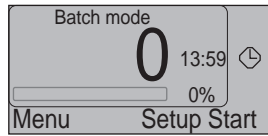

Fig. 11-11: Start screen of Interval batch mode mode

Timer

Using the MAGDOS LP dosing pump *Timer* batch mode mode, you can program two different dosing procedures for a period of one week.

You can provide one or two dosing procedure(s) for each day of the week which start at a specific time (this start time is repeated for each further dosing procedure of the same mode on other days of the week). You can therefore program up to 14 dosing procedures per week. You must specify for each day of the week if no dosing procedure, dosing procedure 1, dosing procedure 2, or both dosing procedures should be started after each other.

Apart from this, you must specify for each dosing procedure whether the dosing pump is to carry out dosing for a specific time or for a specific number of strokes.

You can configure the parameters below for dosing procedure 1:

- *Start time 1*,
- *Run time 1*,
- *Preset strokes 1*,
- *Delivery capacity* (applies to dosing procedures 1 and 2),
- *Mo-Su*.

You can configure the parameters below for dosing procedure 2:

- *Start time 2*,
- *Run time 2*,
- *Preset strokes 2*,
- *Delivery capacity* (applies to dosing procedures 1 and 2),
- *Mo-Su*.



You must set the date, time and day of the week before configuring the parameters. For more information, refer to Page 32.

The *Timer* batch mode mode offers the following configuration options:

Parameter	Explanation
<i>Start time 1</i>	Specifies the required time for dosing procedure 1.
<i>Start time 2</i>	Specifies the required time for dosing procedure 2.
<i>Runtime 1</i>	Specifies the required run time of dosing procedure 1, stated in minutes. The bracket value in the display shows the calculated delivery rate (based on the setting in the <i>Delivery capacity</i> parameter).

Table 11-8: Timer configuration mode

Parameter	Explanation
<i>Runtime 2</i>	Specifies the required run time of dosing procedure 2, stated in minutes. The bracket value in the display shows the calculated delivery rate (based on the setting in the <i>Delivery capacity</i> parameter).
<i>Preset strokes 1</i>	Specifies the required number of strokes of dosing procedure 1. The value that is displayed in brackets indicates the calculated output.
<i>Preset strokes 2</i>	Specifies the required number of strokes of dosing procedure 2. The value that is displayed in brackets indicates the calculated output.
<i>Capacity</i>	Specifies the required stroke frequency for both dosing procedures stated as a percentage of the maximum stroke frequency (see "Delivery capacity data" on page 12).
<i>Mo-Su</i>	Specifies the day of the week on which a specific dosing procedure is to be started.

Table 11-8: Timer configuration mode

11.2.4.4 Programming the dosing procedures

1. Press **Setup**.
 - ▶ The dosing pump displays the current configuration of this operating mode's parameters (Menu 3.41).
2. Press **Setup**.
3. Use the **↑** or **↓** key to choose the *Start time 1* menu item and press **Setup**.
4. Press the **+** key to increment the parameter's value or the **-** key to decrement it.
5. Press **OK**.
6. Using **↑** or **↓** select *Runtime 1* or *Preset strokes 1* and then press **Setup**.
7. Press the **+** key to increment the parameter's value or the **-** key to decrement it.
8. Press **OK**.
9. Use the **↑** or **↓** key to choose the *Capacity* menu item and press **Setup**.
10. Press the **+** key to increment the parameter's value or the **-** key to decrement it.
11. Press **OK**.
 - ▶ The dosing pump displays the current configuration of this operating mode's parameters (Menu 3.41).
12. If required, also program the dosing procedure 2 with the parameters *Start time 2*, *Runtime 2* or *Preset strokes 2*.
13. Use the **↑** or **↓** key to choose the *Mo-Su* menu item and press **Setup**.
14. Press **Next** to select a weekday.
15. Press **1/2/-** to program the dosing procedures for the selected weekday. The following settings can be made:

Setting	Explanation
1	Dosing procedure 1 will be carried out on the selected weekday.
2	Dosing procedure 2 will be carried out on the selected weekday.
3	Dosing procedures 1 and 2 will be carried out on the selected weekday.
-	No dosing procedure will be carried out on the selected weekday.



Please note that, if setting 3 is chosen, dosing procedure 1 and dosing procedure 2 must be programmed with a sufficient time gap between them. If one dosing procedure has not finished before the start time of the other one, the first will be interrupted and the other dosing procedure started.

16. Press **OK.**

- ▶ The dosing pump displays the current configuration of this operating mode's parameters (Menu 3.41).

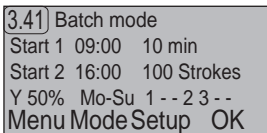

Fig. 11-12: Configuring the batch mode mode Timer

In this example, the dosing procedure 1 starts on Monday and on Friday at 9 o'clock in the morning. Dosing procedure 1 runs for 10 minutes at 50% of the stroke frequency (Y 50%). Dosing procedure 2 starts on Thursday and on Friday at 4 o'clock in the afternoon. Dosing procedure 2 runs for 100 strokes at 50% stroke frequency.

17. Press **OK.**

- ▶ The dosing pump displays the start screen of *Batch mode*.

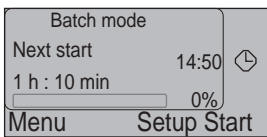

Fig. 11-13: Start-up display of the batch mode mode Timer

The start-up display of the batch mode mode *Timer* shows the remaining time until the next start as well as the current time.

- ✓ **Dosing procedures programmed.**

11.2.4.5 Starting the dosing pump

If batch mode mode *Start/Stop* is set:

1. Press **Start**.
2. Press **Start** again.
 - ▶ The dosing pumps starts dosing immediately. The system automatically calculates the resulting delivery capacity and displays it.

- ✓ **Dosing pump has started.**

If batch mode is set to *Ext. Start*:

1. Press **Start**.
2. Supply a pulse to the pulse input of the dosing pump.
 - ▶ The dosing pumps starts dosing immediately. The system automatically calculates the resulting delivery capacity and displays it.

- ✓ **Dosing pump has started.**

If batch mode mode *Interval* is set:

- ➔ Press **Start**.
 - ▶ The dosing pump displays the time remaining until the set interval is reached. After the time has expired, the pump starts dosing.

- ✓ **Dosing pump has started.**

If batch mode mode *Timer* is set:

- ➔ Press **Start**.
 - ▶ The dosing pump starts dosing when one of the set days of the week and one of the set start times are reached.

- ✓ **Dosing pump has started.**

11.2.4.6 Stopping the dosing pump

- ➔ Press **Stop**.

- ✓ **Dosing pump has stopped.**

11.2.5 Network mode (MAGDOS LP-Net only)

11.2.5.1 Selecting the operating mode

1. Press **Menu**.
2. Use the **↑** or **↓** key to choose the *Operating mode* menu item and press **OK**.
3. Use the **↑** or **↓** key to choose the *Network mode* menu item and press **OK**.
 - ▶ The dosing pump displays the start screen of *Network mode*.

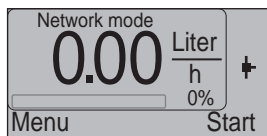

Fig. 11-14: Start screen of Network mode

In *Network mode*, the signal that is connected to the Ethernet connection controls the dosing pump's stroke frequency and number of strokes (see Page 30). In addition, it is possible to transmit in the opposite direction all the disturbance and status messages (see "Addresses of MODBUS TCP/IP protocol (MAGDOS LP-Net)" on page 64).

You do not need to make any further configurations in the operating mode.

You must, however, enter or check the IP address (see "Set "IP address" menu item (MAGDOS LP-Net only)" on page 36).

The dosing pump has a globally unique MAC number for unambiguous identification (for example: "00-C0-3D-00-27-8B"). To uniquely identify the dosing pump on a TCP/IP network, it must be given an IP number (for example: "169.254.55.114"). The local network administrator assigns the IP number. There is no DHCP function to automatically assign numbers.

If you operate several dosing pumps on one network, their IP addresses must be matched with each other to differentiate them and to make possible unique addressing.

TCP/IP packets must conform with the Modbus TCP/IP protocol; this means that they can be sent from and received by the TOPAX DX Net multi-channel controller, by an Ethernet-capable PLC or a PC control console.

You can only operate the dosing pump in a local TCP/IP network (not via a gateway).

The dosing pump monitors the network connection. If packets fail, the dosing pump automatically stops delivery. This means that the PLC or the PC control console must continuously trigger the dosing pump in an interval of less than one second.

A Web server is integrated in the dosing pump. To check the network connection, you can surf to the Web server from a PC with a Web browser and read out the current delivery capacity. Addressing is by means of the IP address.

For more information about parameterising the Modbus TCP/IP protocol, see Section "Addresses of MODBUS TCP/IP protocol (MAGDOS LP-Net)" (see page 64).

11.3 External On/Off via Release input

Regardless of the selected operating mode, you can start or stop the MAGDOS LP dosing pump by means of the closed switching contact on the Release input.

If you set the function (see "Set "Release input" menu item" on page 34), the system displays in the selected operating mode the symbol for configuration of the Release input (see also "Explanation of the menu icons" on page 31).



Fig. 11-15: Start screen of Analog input with icon for open contact

11.3.1 Starting the dosing pump

If *Run = contact* is set:

- ➔ Close the switching contact on the Release input.
- ✓ **Dosing pump has started.**

If *Run = open* is set:

- ➔ Open the switching contact on the Release input.
- ✓ **Dosing pump has started.**

11.3.2 Stopping the dosing pump

If *Run = contact* is set:

- ➔ Open the switching contact on the Release input.
- ✓ **Dosing pump has stopped.**

If *Run = open* is set:

- ➔ Close the switching contact on the Release input.
- ✓ **Dosing pump has stopped.**

11.4 Decommissioning the dosing pump

Perform the following working steps:

1. Stop the dosing pump in accordance with the selected operating mode.
 2. Unplug the dosing pump's mains plug from the power supply.
 3. Disconnect all electrical connections.
 4. Depressurize all the hydraulic parts in the system.
 5. Unplug all the hydraulic connections on the dosing pump.
 6. Empty the dosing head.
 7. Remove any residual dosing medium from the dosing head by flushing the system with a washing agent. Ensure that the washing agent is compatible with the dosing medium.
- ✓ **Dosing pump is decommissioned.**

11.5 Shutting down in an emergency

- In an emergency, you must immediately disconnect the dosing pump from the mains supply or activate the Emergency Stop switch installed in the system.
- Depending on the type of incident, you must depressurized the hydraulic connections or locked to prevent dosing medium from escaping.
- You must follow the safety data sheet of the dosing medium.

11.6 Storage

Storing the dosing pump correctly extends its service life. You should avoid negative influences like extreme temperatures, high humidity, dust, chemicals, etc.

Ensure ideal storage conditions where possible:

- the storage place must be cold, dry, dust-free and generously ventilated,
- Temperatures between + 2 °C and + 40 °C (with PP and PVDF dosing heads, between + 2 °C and + 60 °C),
- Relative humidity must not exceed 90%.

11.7 Transportation

Perform the following working steps:

- The unit should be thoroughly cleaned. Any dangerous dosing media must be additionally neutralised and decontaminated.
- All accessories should be dismantled.
- All openings should be closed, so that no foreign objects can get into the system.
- The dosing pump must be suitably packed, preferably in the original packing, for transportation.

Should the unit be sent back to the manufacturer, please follow chapters "Declaration of harmlessness" (see page 70) and "Warranty application" (see page 72).

11.8 Disposal of old units

- The waste unit must be thoroughly cleaned. Any dangerous dosing media must be additionally neutralised and decontaminated.
- Any residual dosing media must be removed in a professional manner.
- The dosing pump must be disposed of in accordance with applicable local laws and regulations. The unit does not belong to household waste!
- As the disposal regulations may differ from country to country in the European Union, please consult your supplier if necessary.

12 Maintenance

Lutz-Jesco dosing pumps are produced to the highest quality standards and have a long service life. Nevertheless, some of their parts are subject to wear due to operation (e.g. diaphragms, valve seats, valve balls). This means that regular visual inspections are necessary to ensure a long operating life. Regular maintenance will protect the dosing pump from operation interruptions.

	DANGER
<p>Danger to life due to electric shock</p> <p>Live parts can inflict fatal injuries.</p> <ul style="list-style-type: none"> ⇒ Before carrying out any maintenance work, always disconnect the dosing pump from the power supply. ⇒ Secure the dosing pump from accidental power-up. 	

	WARNING
<p>Caustic burns or other burns through dosing media!</p> <p>While working on the dosing head, valves and connections, you may come into contact with dosing media.</p> <ul style="list-style-type: none"> ⇒ Use sufficient personal protective equipment. ⇒ Rinse the dosing pump with a medium (e.g. water) which does not pose any risk. ⇒ Release pressure in hydraulic parts. ⇒ Never look into open ends of plugged pipelines and valves. 	

	WARNING
<p>Caustic burns or other burns through dosing media!</p> <p>After connecting the mains supply, residual dosing media in the dosing head can spray out.</p> <ul style="list-style-type: none"> ⇒ Before connecting the mains supply, connect the dosing lines. ⇒ Check that all the screw connections have been tightened correctly and are leak-proof. 	

	CAUTION
<p>Danger of personal injury and material damage!</p> <p>The dosing pump can generate a pressure that is many times the rated one. The dosing medium can escape in the case of material failure or wear on the dosing head, the connection pipe or the seals that are used.</p> <ul style="list-style-type: none"> ⇒ Carry out maintenance work at the recommended intervals. 	

	CAUTION
<p>Increased risk of accidents due to insufficient qualification of personnel!</p> <p>Dosing pumps and their accessories may only be installed, operated and maintained by personnel with sufficient qualifications. Insufficient qualification will raise the risk of accidents.</p> <ul style="list-style-type: none"> ⇒ Ensure that all action is taken only by personnel with sufficient and corresponding qualifications. ⇒ Prevent access to the system for unauthorised persons. 	

12.1 Maintenance intervals

This table gives you an overview of maintenance work and the intervals at which you must carry it out. The next few chapters contain instructions for carrying out this work.

Maintenance work to be carried out	Frequency
Check that piping is seated firmly	Regularly
Check that suction and discharge valves are seated firmly	Regularly
Clean suction and discharge valves	Regularly
Check that electrical connections are not damaged	Regularly
Tighten dosing head bolts	<ul style="list-style-type: none"> ■ Regularly ■ Before initial commissioning ■ Each time you replace the diaphragms
Check diaphragms for leakage due to rupture	Regularly (assuming that no leakage monitoring facility was installed)
Check that the installed accessories are functioning correctly	Regularly
Check the dosing pump for unusual noises during operation, unusual temperatures or smells	Regularly

Table 12-1: Maintenance information and maintenance intervals

Maintenance work to be carried out	Frequency
Replace parts that are subject to wear (diaphragms, valves, seals, etc.)	if you detect unacceptable wear
Rinse out and clean the dosing pump	<ul style="list-style-type: none"> ■ before changing diaphragms ■ before decommissioning for a long period of time ■ after feeding aggressive, adhesive, crystallising or contaminated liquids

Table 12-1: Maintenance information and maintenance intervals

12.2 Tighten dosing head bolts

➔ Tighten the dosing head bolts in diagonally opposite sequence with a torque wrench.

The necessary torque is 180 Ncm.

12.3 Change the diaphragm

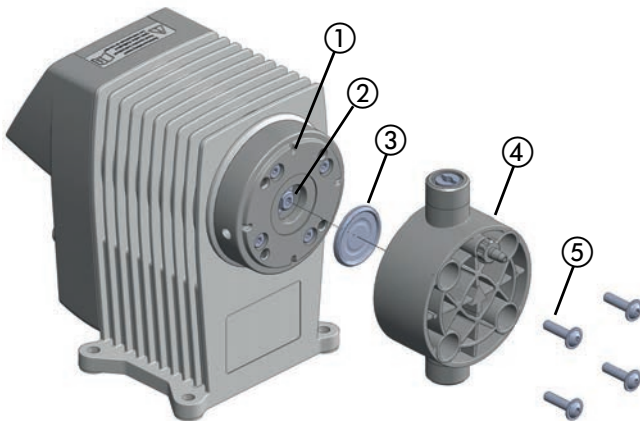

Fig. 12-1: Exploded view of the diaphragm and dosing head

12.3.1 Dismount the old diaphragm

Precondition for action:

- ✓ You have disconnected the dosing pump from the mains supply.
- ✓ You have depressurised the hydraulic sections of the plant.
- ✓ You have rinsed the dosing pump using a safe medium (e.g. water).

Perform the following working steps:

1. Screw out the four screws (5) on the dosing head using a suitable tool (SW 3 Allen key) and take off the dosing head (4).
2. Use pliers to bend the edge of the diaphragm (3) slightly upwards and screw it out counter-clockwise.

12.3.2 Install a new diaphragm

Precondition for action:

- ✓ You have thoroughly cleaned the diaphragm rod (2) and the diaphragm flange (1) so that the new diaphragm is not affected by dosing medium residues.
 - ✓ You have slightly greased the diaphragm thread (3) (e.g. using Molykote Longterm W2).
1. Screw the diaphragm manually (3) in the clockwise direction until it safely contacts into the diaphragm rod.
 2. Bring the dosing head into position and insert the screws. First tighten the screws finger-tight. After this, tighten the screws in diagonally opposite sequence, e.g. top left and bottom right and top tight and bottom left.

NOTICE

Damage to the dosing head/leakiness of the diaphragm

If you tighten the screws too much, this can lead to the dosing head being damaged. However, not tightening the screws enough leads to the diaphragm being leaky and correct functioning being affected.

⇒ Tighten the screws to a torque of 180 Ncm.

✓ **Diaphragm change finished.**

i It may be necessary to recalibrate the dosing pump after replacing the diaphragm or other spare parts on it. For more information, refer to page 39.

12.4 Clean suction and discharge valves

Contaminated valves affect the dosing precision and this means that you should clean the valves on a regular basis.

With dosing heads made of plastic, when replacing a valve you must replace the complete dosing head (see „Spare parts“ on page 54).

13 Troubleshooting

See below for information about how to rectify faults on the device or the system. If you cannot eliminate the fault, please consult with the manufacturer on further measures or return the dosing pump for repair.

13.1 Type of fault

13.1.1 Dosing pump not delivering or output too low

Possible cause	Remedy
Wrong type of dosing pump selected	→ Check the dosing pump's technical data and if necessary select a type with a higher delivery capacity.
Valve leaking or blocked	→ Clean the valve and vent the dosing pump. → Tighten the screw connections.
Valve installed incorrectly	→ Reassemble the valve. Ensure that the valve balls are located above the valve seats.
Valve damaged (e.g. valve balls)	→ Remove the damaged parts or install a new valve.
Suction line is leaking	→ Seal the leak locations or replace the parts.
Suction line is blocked (e.g. screen in foot valve)	→ Clean the suction line
Shut-off valves closed	→ Open the shut-off valves Inspect the dosing pump for possible damage.
Suction head too high	→ Set the dosing pump to feed or reduce the suction head. → Install a priming aid.
Viscosity too high	→ Possibly reduce the concentration of the dosing medium or increase the temperature. → Install spring-loaded valves. → Increase the pipe diameter.
Current supply interrupted	→ Reconnect the current supply
The dosing pump's electrical data does not match that of the mains supply	→ Check the electrical installation.
Eco-Mode set (driving power reduced)	→ Switch off Eco-Mode.

Table 13-1: Type of fault: Dosing pump not delivering or output too low

Possible cause	Remedy
System backpressure too high (measured at discharge connection of dosing pump)	→ Clean blocked injection nozzle. → Install pulsation dampeners to reduce pressure peaks if pipes are too long. → Check function of safety valves.

Table 13-1: Type of fault: Dosing pump not delivering or output too low

13.1.2 Dosing pump does not prime

Possible cause	Remedy
Valve leaking or blocked	→ Clean the valve and vent the dosing pump. → Tighten the screw connections.
Valve installed incorrectly	→ Reassemble the valve. Ensure that the valve balls are located above the valve seats.
Valve damaged (e.g. valve balls)	→ Remove the damaged parts or install a new valve.
Suction line is leaking	→ Seal the leak locations or replace the parts.
Suction line is blocked (e.g. screen in foot valve)	→ Clean the suction line
Shut-off valves closed	→ Open the shut-off valves Inspect the dosing pump for possible damage.
Suction head too high	→ Set the dosing pump to feed or reduce the suction head. → Install a priming aid.
Viscosity too high	→ Possibly reduce the concentration of the dosing medium or increase the temperature. → Install spring-loaded valves. → Increase the pipe diameter.
Current supply interrupted	→ Reconnect the current supply
Dry the valves	→ Dampen the dosing head and the valves → Vent the dosing head.
Air in the suction line with simultaneous pressure on the discharge valve	→ Vent the dosing head or the lines.

Table 13-2: Type of fault: Dosing pump does not prime

13.1.3 Delivery rate varies

Possible cause	Remedy
Valve leaking or blocked	<ul style="list-style-type: none"> ➔ Clean the valve and vent the dosing pump. ➔ Tighten the screw connections.
Valve damaged (e.g. valve balls)	➔ Remove the damaged parts or install a new valve.
Suction line is leaking	➔ Seal the leak locations or replace the parts.
Suction line is blocked (e.g. screen in foot valve)	➔ Clean the suction line
Viscosity too high	<ul style="list-style-type: none"> ➔ Possibly reduce the concentration of the dosing medium or increase the temperature. ➔ Install spring-loaded valves. ➔ Increase the pipe diameter.
The dosing pump's electrical data does not match that of the mains supply	➔ Check the electrical installation.
Suction side pressure too high (pump siphoning)	➔ Install a pressure control valve in the pressure line.
Pressure peaks due to acceleration with long suction lines	➔ Install a suction pressure regulator.
Imprecise dosing due to changeable positive and negative suction heads.	➔ Install a suction pressure regulator.
System backpressure too high (measured at discharge connection of dosing pump)	<ul style="list-style-type: none"> ➔ Clean blocked injection nozzle. ➔ Install pulsation dampeners to reduce pressure peaks if pipes are too long. ➔ Check function of safety valves.

Table 13-3: Type of fault: Delivery rate varies

13.1.4 No stroke movement observed

Possible cause	Remedy
Diaphragm return spring broken.	➔ Contact the manufacturer.
Current supply interrupted	➔ Reconnect the current supply
The dosing pump's electrical data does not match that of the mains supply	➔ Check the electrical installation.

Table 13-4: Type of fault: No stroke movement observed

Possible cause	Remedy
Pressure peaks due to acceleration with long suction lines	➔ Install a suction pressure regulator.
System backpressure too high (measured at discharge connection of dosing pump)	<ul style="list-style-type: none"> ➔ Clean blocked injection nozzle. ➔ Install pulsation dampeners to reduce pressure peaks if pipes are too long. ➔ Check function of safety valves.

Table 13-4: Type of fault: No stroke movement observed

13.1.5 Dosing pump delivery rate too high

Possible cause	Remedy
Suction side pressure too high (pump siphoning)	➔ Install a pressure control valve in the pressure line.
Pressure peaks due to acceleration with long suction lines	➔ Install a suction pressure regulator.

Table 13-5: Type of fault: Dosing pump delivery rate too high

13.1.6 Diaphragm is torn or tears too often

Possible cause	Remedy
Shut-off valves closed	➔ Open the shut-off valves Inspect the dosing pump for possible damage.
Pressure peaks due to acceleration with long suction lines	➔ Install a suction pressure regulator.
The materials are not suitable for the dosing medium being used	➔ Check the resistance of the materials.
Diaphragm not screwed up to the end stop on the diaphragm rod	➔ Screw a new diaphragm up to the end stop.
System backpressure too high (measured at discharge connection of dosing pump)	<ul style="list-style-type: none"> ➔ Clean blocked injection nozzle. ➔ Install pulsation dampeners to reduce pressure peaks if pipes are too long. ➔ Check function of safety valves.
Media sediment in dosing head	➔ Clean the dosing head.

Table 13-6: Type of fault: Diaphragm is torn or tears too often

13.1.7 Loud noises on the dosing pump

Possible cause	Remedy
The drive magnet's stop damper is worn-out	→ Contact the manufacturer.

Table 13-7: Type of fault: Loud noises on the dosing pump

13.2 List of control unit messages

Display	Description in "Messages" menu	Explanation	Error code Messages Menu	Stop the dosing pump	Fault signalling relay
-	Restart pump	Reset to factory settings	#00	Yes	Yes
Tank at minimum level	Minimum level	Level monitoring messages	#01	No	Yes
Tank empty	Empty level		#02	Yes	Yes
Flowcon error	Dosing control	Flowcon reports faulty strokes Dosing pump continues to run	#05	No	Yes
Flowcon stop	Dosing control	Flowcon reports faulty strokes Dosing pump stopped	#05	Yes	Yes
Release input stop	No external release	Dosing pump waiting for external On/Off	#06	Yes	Yes
Diaphragm rupture stop	Diaphragm rupture	Leakage sensor reports diaphragm rupture	#07	Yes	Yes
Analogue input error	20mA input error	No signal or faulty signal at the analogue input	#08	Yes	Yes
Stop	Manual stop	Dosing pump stopped by user	#09	Yes	Yes
Set-up error	General unit error	Internal hardware fault	#10	Yes	Yes
Stroke error	General unit error	Internal hardware fault	#10	No	Yes
-	Excess temperature	Temperature monitoring	#11	Yes	Yes
Offline	Offline	No signal in network operation or faulty data transfer	#12	Yes	Yes
Battery error	Clock	Time error stops dosing pump in batch operation, timer type	#13	Yes	Yes
Stroke buffer maximum	Stroke buffer full	Stroke buffer is too small	#14	No	No
Mains supply error	Voltage error	Overvoltage	#15	Yes	Yes
-	Alarm list deleted	Delete list of messages	#18	No	No

Table 13-8: List of control unit messages

14 Spare parts

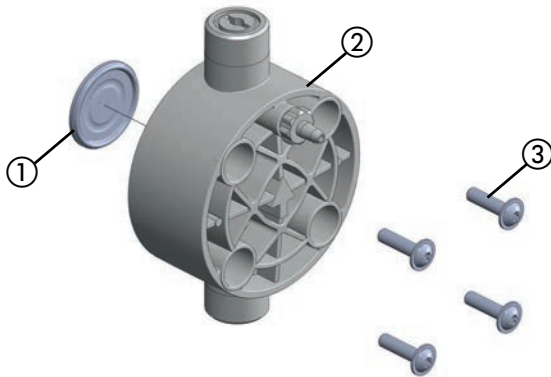

Fig. 14-1: Spare parts kits (dosing head made of plastic)

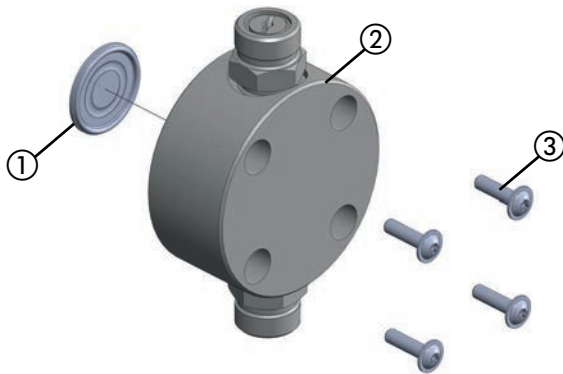

Fig. 14-2: Spare parts kits (dosing head made of stainless steel)

Required kits for a complete service:

- 1 diaphragm spare parts kit,
- 1 dosing head spare parts kit including valves.

14.1 Diaphragm spare parts kits

Diaphragm spare parts kit containing:

- 1 diaphragm (1),
- 1 set of dosing head screws (3).

Diaphragm kit	Type	Part No.
	LP 05, LP 1	39121
	LP 2, LP 4	39122
	LP 6, LP 10, LP 15	39123

14.2 Dosing head spare parts kits including valves

Dosing head spare parts kits including screws containing:

- Dosing head (2),
- Valves,
- 1 set of dosing head screws (3).

PVC	Type	Part No.
Glass/PVDF/FPM (ball/seat/seals)	LP 05, LP 1	38981
	LP 2, LP 4	38982
	LP 6, LP 10, LP 15	38983

PP	Type	Part No.
Glass/PVDF/FPM (ball/seat/seals)	LP 05, LP 1	38978
	LP 2, LP 4	38979
	LP 6, LP 10, LP 15	38980

PVDF	Type	Part No.
PTFE/PVDF/FPM (ball/seat/seals)	LP 05, LP 1	38984
	LP 2, LP 4	38985
	LP 6, LP 10, LP 15	38986

1.4571	Type	Part No.
Stainless steel / stain- less steel / FPM (ball/seat/seals)	LP 05, LP 1	39942
	LP 2, LP 4	39943
	LP 6, LP 10, LP 15	39944

15 Delivery characteristic curves

This Chapter is intended to give you an idea of the delivery capacity that the dosing pump can achieve at specific back pressures. These delivery capacities were determined on the manufacturer's test stands. They apply at 20 °C (68 °F) for water, at 100 % stroke frequency. The delivery capacity depends on the medium (density and viscosity) and temperature. Since these conditions vary at every installation location, you should calibrate the dosing pump.

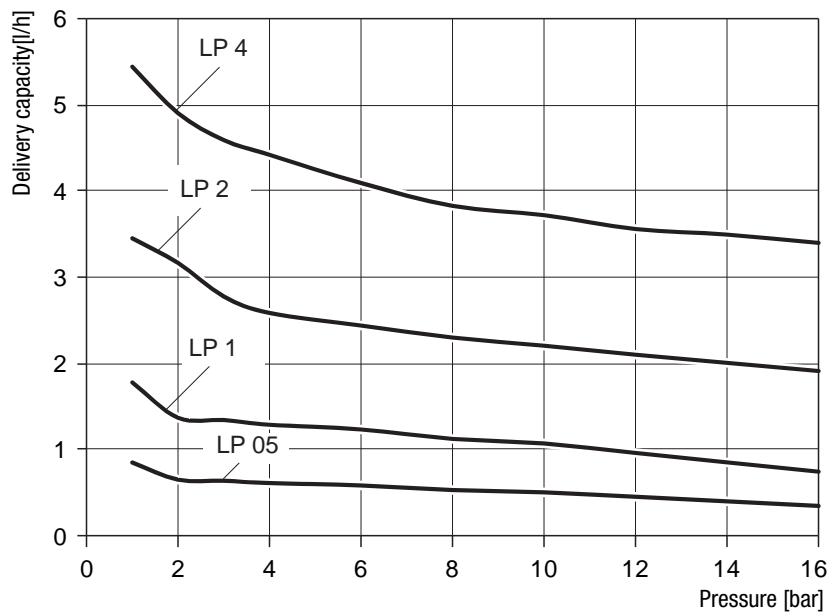

Fig. 15-1: Delivery capacity diagrams of MAGDOS LP 05 - 4

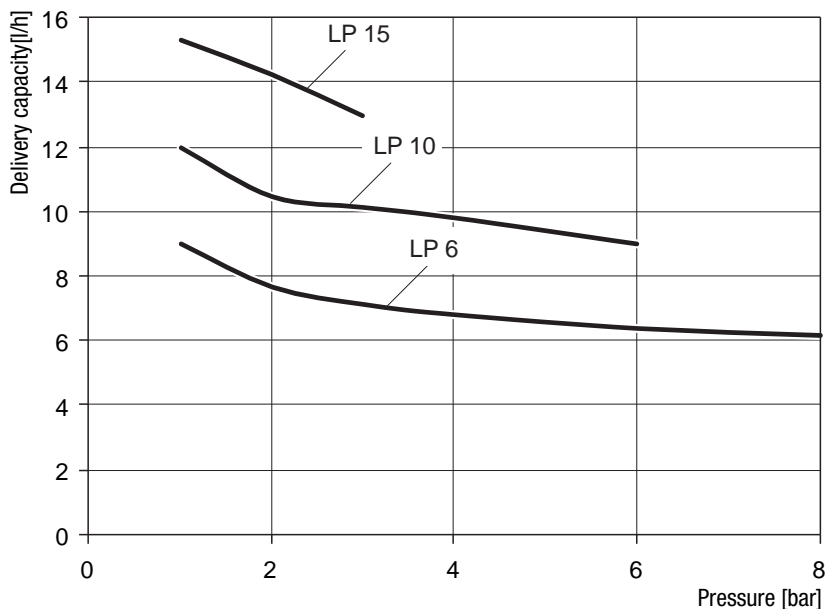
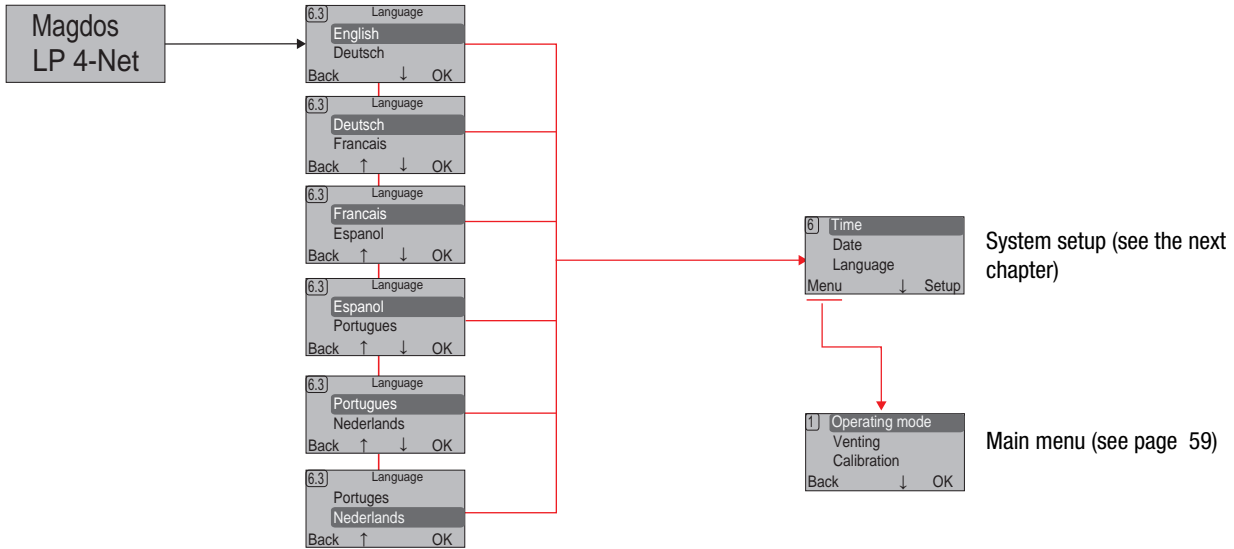

Fig. 15-2: Delivery capacity diagrams of MAGDOS LP 6 - 15

16 Menu structure of the Control Unit

16.1 Program start



16.2 System setup

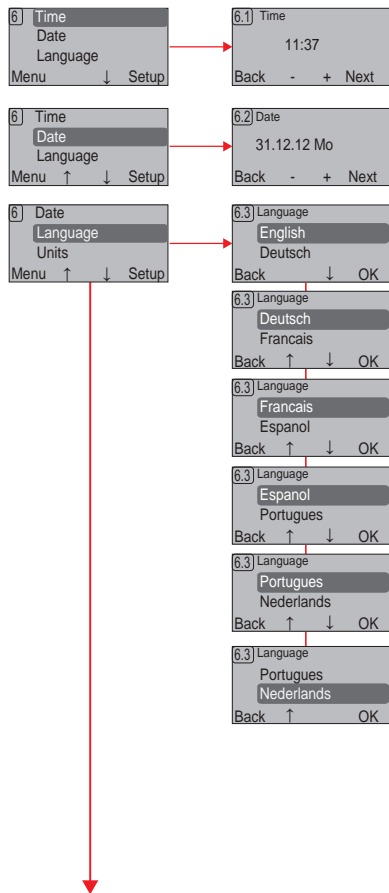

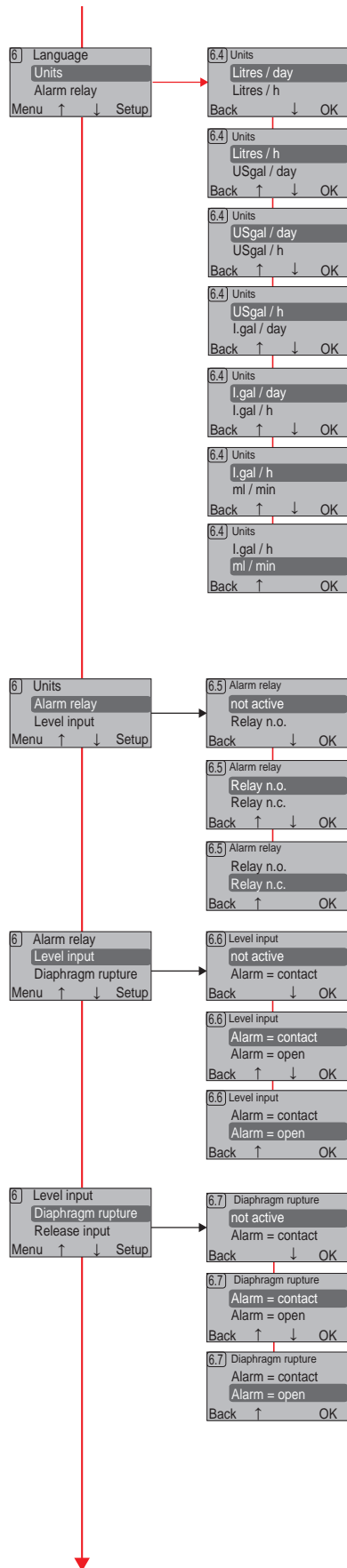

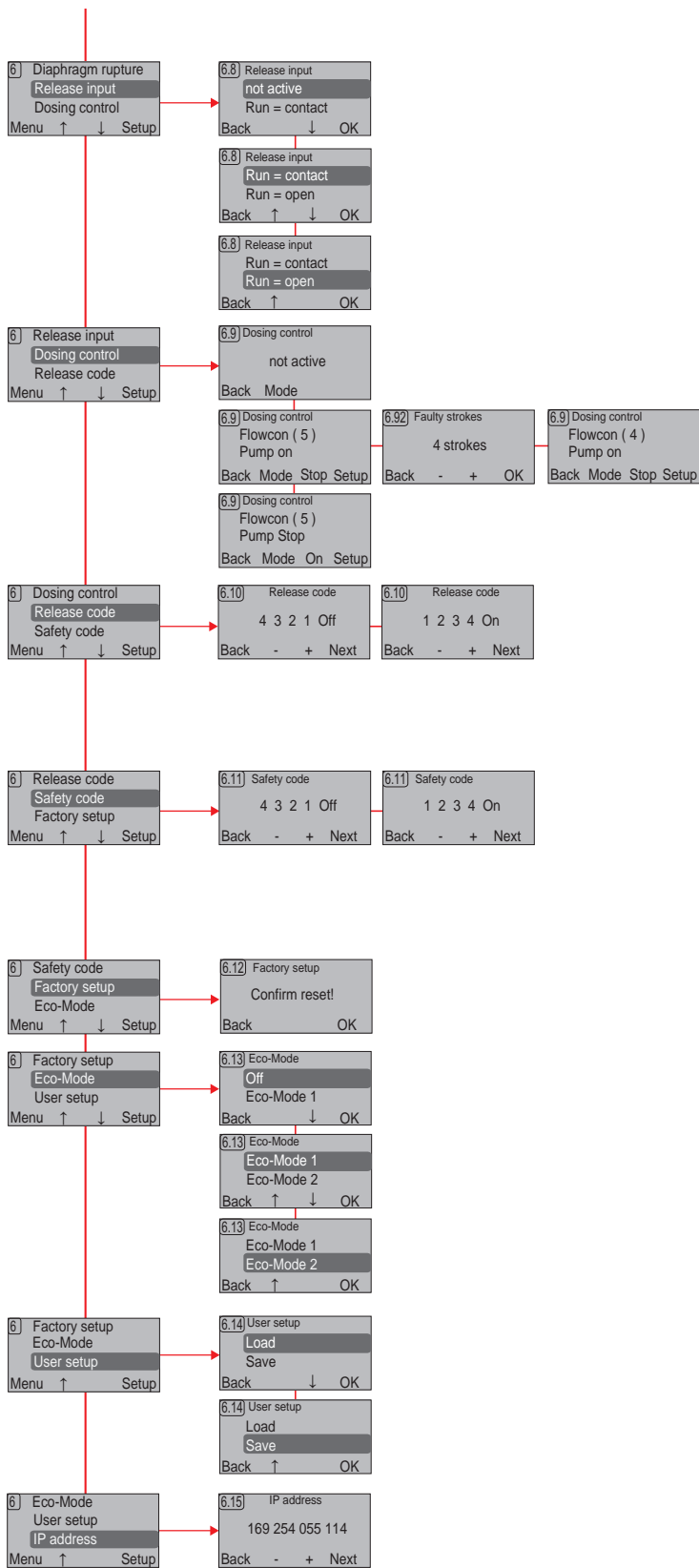

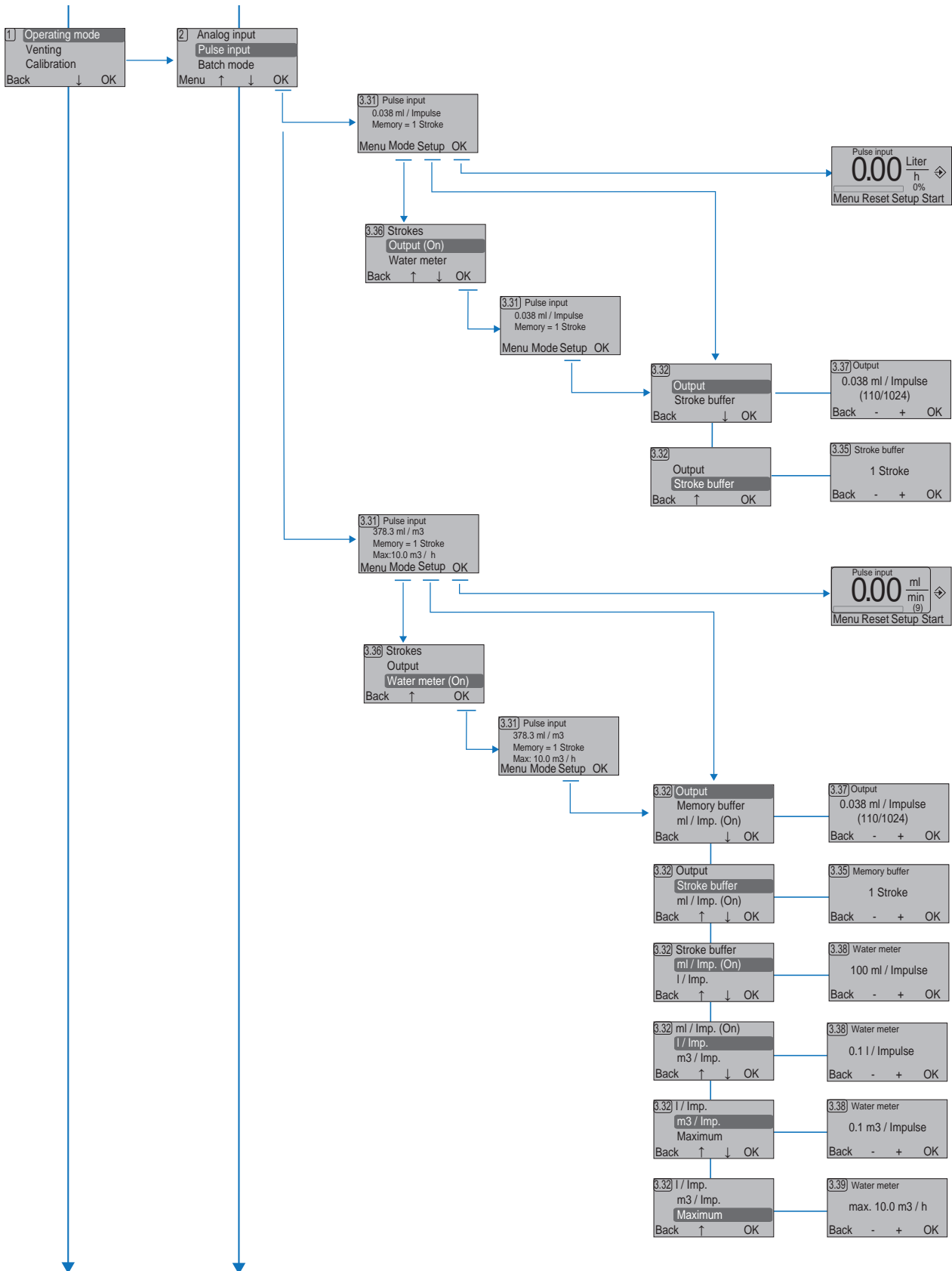

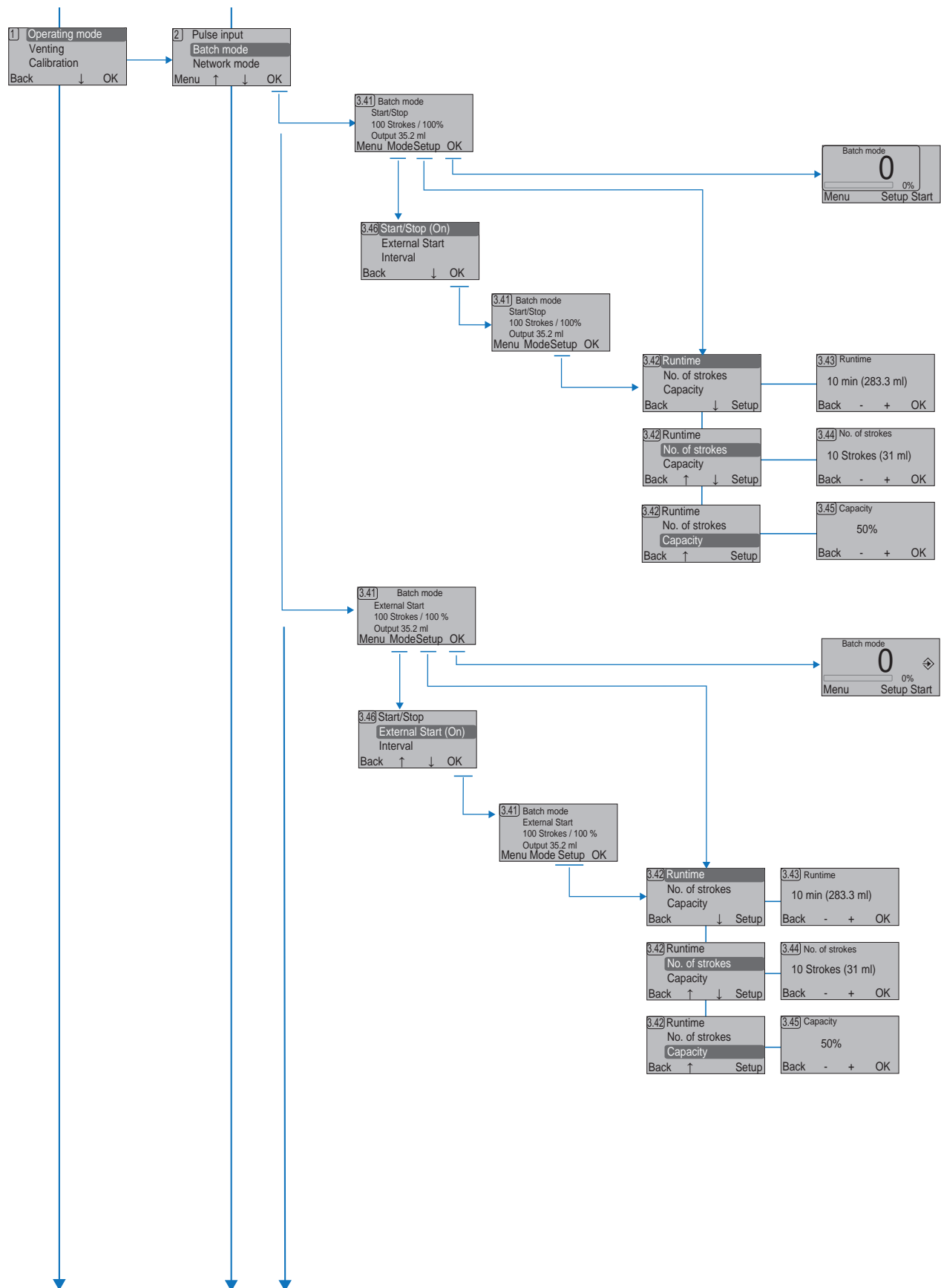

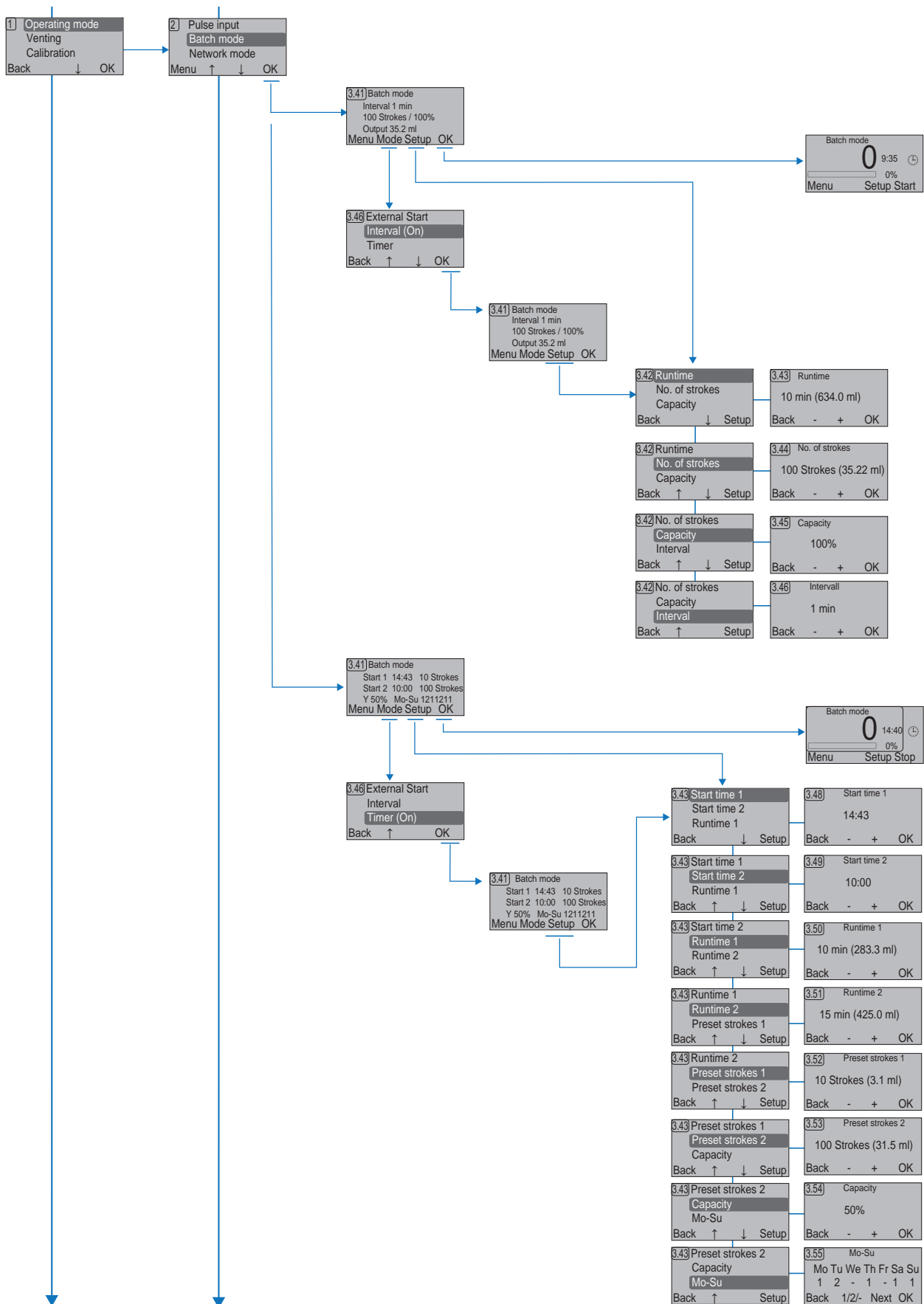

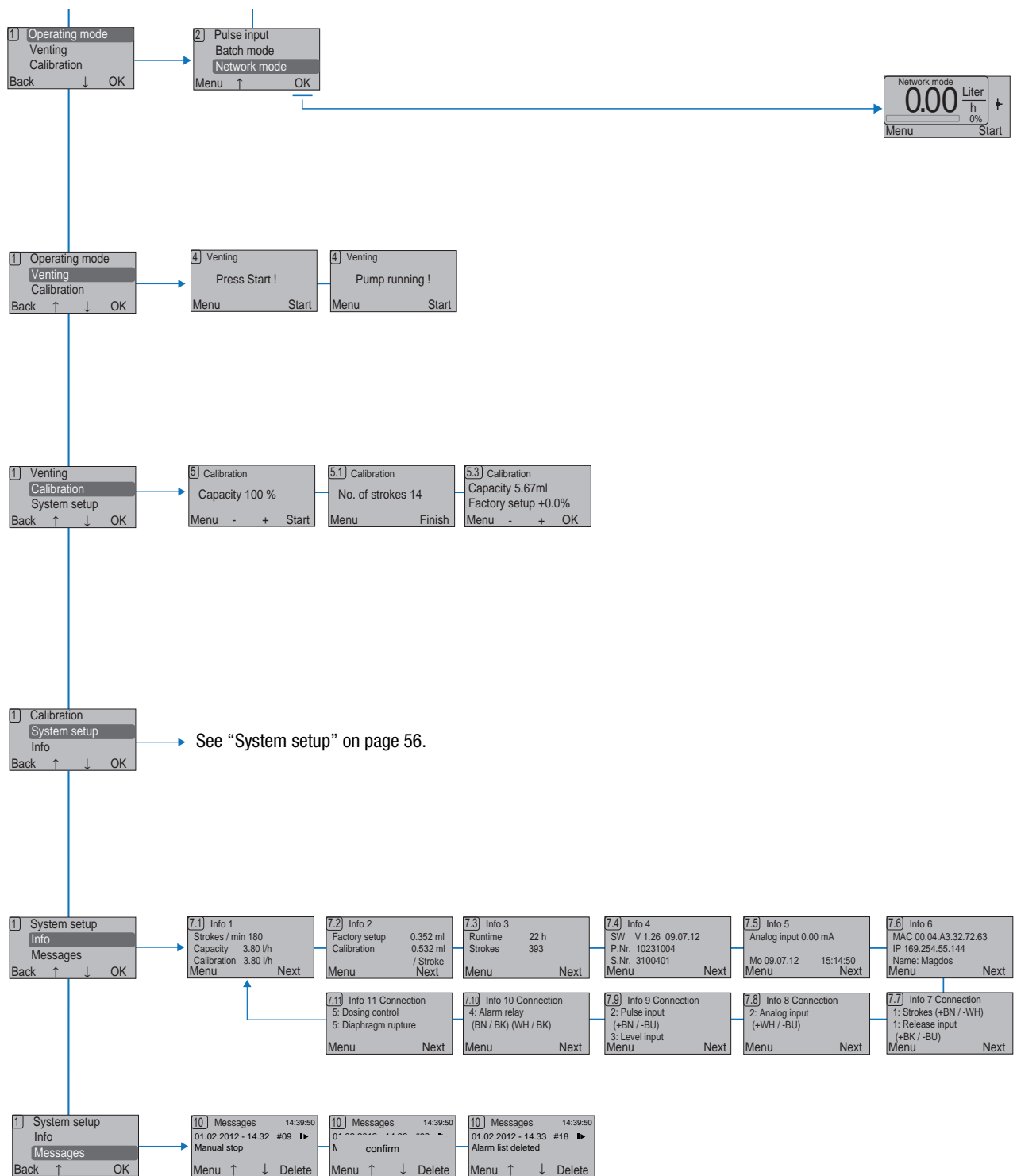

17 Appendix

17.1 Addresses of MODBUS TCP/IP protocol (MAGDOS LP-Net)

Address	Word	r/w	Type	Field	Description
0 - 3	-				
4	1	r	Number	Model	0300 _{hex} : LP 05 0301 _{hex} : LP 1 0302 _{hex} : LP 2 0303 _{hex} : LP 4 0304 _{hex} : LP 6 0305 _{hex} : LP 10 0306 _{hex} : LP 15
5	1	r	Number	Nominal delivery capacity	Example: 380 = "3,8 l/h"
6 - 7	2	r	Text	Software Version:	Example: "1.20"
8 - 9	-				
10	1	r	Number	Operating hours	
11	1	r	Number	Operating seconds	
12	1	r	Number	Modbus address	= 1
13 - 14	2	r	Number	MAC address	
15	-				
16 - 17	2	r	Number	IP address	
18	1	r	Number	Watchdog	Example: 12300 = "12,3 s", max. 15000
19 - 29	-				
30 - 35	6	r/w	Text	Device names	Max. of 12 characters
36 - 39	-				
40 - 45	6	r	Text	Serial number	Max. of 11 characters
46 - 49	-				
50	1	r	Number	Operating mode	0000 _{hex} : Manual operation 0001 _{hex} : Analog input 0002 _{hex} : Pulse input 0003 _{hex} : Batch mode 0004 _{hex} : Network mode
51	1	r/w	Number	Stroke frequency control variable	0 ... 1000 The watchdog is reset to 0 by writing the control variable.
52	1	r	Number	Actual delivery rate	Example: 240 = "2,4 l/h"

Table 17-1: Addresses of MODBUS TCP/IP protocol (MAGDOS LP-Net)

Address	Word	r/w	Type	Field	Description
53	1	r	Number	Reporting of last event	0300 _{hex} + 0000 _{hex} : Not an error 0001 _{hex} : Container at minimum level 0002 _{hex} : Container at empty level 0005 _{hex} : Flowcon/dosing control error 0006 _{hex} : Release input stop 0007 _{hex} : Diaphragm rupture 0008 _{hex} : 0/4 ... 20mA input error 0009 _{hex} : Manual stop 000A _{hex} : General unit error 000B _{hex} : Over temperature/overload 000C _{hex} : Offline/transfer error 000D _{hex} : RTC error/battery error 000E _{hex} : Stroke buffer maximum 000E _{hex} : Voltage error 0010 _{hex} : List of messages deleted
54	-				
55	1	r	Number	Current on 0/4 ... 20 mA input	Example: 1814 = "18.14 mA"
56	1	r/w	Number	Specified delivery capacity %	Example: 830 = "83.0%"
57	1	r/w	Number	Countdown specification	With batch mode, start amount specified under No. of strokes
58	1	r/w	Number	Current countdown	In batch mode, (Type Start/Stop or Ext. Start), the number of strokes that still have to be carried out. Example: 1200 = "20 strokes" With batch mode (interval or timer type) the strokes that have still to be carried out at 100 % delivery capacity. You must multiply the value by the delivery capacity (address 56).
59-60	2	r	Number	Stroke counter	Number of strokes that have been carried out up to now
61 - 62	-				
63	1	r	Number	Strokes/min. max.	Maximum output after factory calibration
64	1	r/w	Number	Strokes/min. calibrated	Output after calibration by customer
90 - 91	High	r	Number	Status bit message	00000000 _{bin} 00000010 _{bin} : List of messages deleted
	Low	r	Number		0000 0000 _{bin} 0000 0001 _{bin} : Container at minimum level 0000 0000 _{bin} 0000 0010 _{bin} : Container at empty level 0000 0000 _{bin} 0001 0000 _{bin} : Flowcon/dosing control error 0000 0000 _{bin} 0010 0000 _{bin} : Release input stop 0000 0000 _{bin} 0100 0000 _{bin} : Diaphragm rupture 0000 0000 _{bin} 1000 0000 _{bin} : 0/4 - 20mA input error 0000 0001 _{bin} 0000 0000 _{bin} : Manual stop 0000 0010 _{bin} 0000 0000 _{bin} : General unit error 0000 0100 _{bin} 0000 0000 _{bin} : Over temperature/overload 0000 1000 _{bin} 0000 0000 _{bin} : Offline/transfer error 0001 0000 _{bin} 0000 0000 _{bin} : RTC error/battery error 0010 0000 _{bin} 0000 0000 _{bin} : Stroke buffer maximum 0100 0000 _{bin} 0000 0000 _{bin} : Voltage error

Table 17-1: Addresses of MODBUS TCP/IP protocol (MAGDOS LP-Net)

r/w = read/write, 1 address space = 1 word = 2 Bytes = 16 Bits

Type	Description
Number	2 Bytes = 0000 _{hex} ... FFFF _{hex} = 0 _{dec} ... 65536 _{dec} = 00000000 _{bin} ... 11111111 _{bin}
Text	2 Bytes = "aa" _{ASCII} ... "ZZ" _{ASCII}

17.2 Default settings

Preset operating mode *Manual mode* (delivery capacity 0 %)

Parameter		Factory setting	Own setting
Language		English	
Units		Litres/hr.	
Alarm relay		Not active	
Level input		Not active	
Diaphragm rupture		Not active	
Release input		Not active	
Dosing control		Not active	
Release code		Off	
Safety code		Off	
Eco-Mode		Off	
IP address (MAGDOS LP-Net)		169,254,055,114	
Analog input	0/4 ... 0.20mA	4..20 mA	
	0%	4.0 mA	
	100%	20.00 mA	
Pulse input	Type	Strokes	
	Strokes p. pulse	1 stroke	
	Pulses p. stroke	1 pulse	
	Stroke buffer	1 stroke	
	Output	64/64	
	Unit	ml/pulse	
	Maximum	10 m3 /hr.	

Table 17-2: Default settings

	Parameter	Factory setting	Own setting
Batch mode	Type	Start/Stop	
	Runtime	10 min.	
	No. of strokes	100 strokes	
	Capacity	100 %	
	Interval	10 min.	
	Start time 1	08:00	
	Start time 2	10:00	
	Runtime 1	10 min.	
	Runtime 2	10 min.	
	Preset strokes 1	100 strokes	
	Preset strokes 2	100 strokes	
	Capacity	100 %	

Table 17-2: Default settings

18 EC Declaration of Conformity



(DE) EG-Konformitätserklärung

Der Unterzeichnete Lutz-Jesco GmbH, Am Bostelberge 19, 30900 Wedemark, bestätigt, dass die nachfolgend bezeichneten Geräte in der von uns in Verkehr gebrachten Ausführung die Anforderungen der harmonisierten EU-Richtlinien, EU-Sicherheitsstandards und produktspezifischen Standards erfüllen. Bei einer nicht mit uns abgestimmten Änderung der Geräte verliert diese Erklärung ihre Gültigkeit.

(EN) EC Declaration of Conformity

The undersigned Lutz-Jesco GmbH, Am Bostelberge 19, 30900 Wedemark, hereby certifies that, when leaving our factory, the units indicated below are in accordance with the harmonised EC guidelines, EC standards of safety and product specific standards. This certificate becomes void if the units are modified without our approval.

(FR) Certificat de conformité aux directives européennes

Le constructeur, soussigné: Lutz-Jesco GmbH, Am Bostelberge 19, 30900 Wedemark, déclare qu'à la sortie de ses usines le matériel neuf désigné ci-dessous était conforme aux prescriptions des directives européennes énoncées ci-après et conforme aux règles de sécurité et autres règles qui lui sont applicables dans le cadre de l'Union européenne. Toute modification portée sur ce produit sans l'accord express de Jesco supprime la validité de ce certificat.

(ES) Declaración de conformidad de la UE

El que suscribe Lutz-Jesco GmbH, Am Bostelberge 19, 30900 Wedemark, declara que la presente mercancía, objeto de la presente declaración, cumple con todas las normas de la UE, en lo que a normas técnicas, de homologación y de seguridad se refiere. En caso de realizar cualquier modificación en la presente mercancía sin nuestra previa autorización, esta declaración pierde su validez.

(NL) EU-overeenstemmingsverklaring

Ondergetekende Lutz-Jesco GmbH, Am Bostelberge 19, 30900 Wedemark, bevestigt, dat het volgende genoemde apparaat in de door ons in de handel gebrachte uitvoering voldoet aan de eis van, en in overeenstemming is met de EU-richtlijnen, de EU-veiligheidsstandaard en de voor het product specifieke standaard. Bij een niet met ons afgestemde verandering aan het apparaat verliest deze verklaring haar geldigheid.

(HU) EG (EK)– Egyezőségi nyilatkozat

A Lutz-Jesco GmbH, Am Bostelberge 19, 30900 Wedemark ezúton kijelenti, hogy a szóban forgó termék annak tervezése és szerkezeti módja, valamint forgalomba hozott kivitele alapján a vonatkozó alapvető biztonság technikai és egészségügyi követelményeknek és az alábbi felsorolt EG –irányelveknek minden szempontból megfelel. A terméken engedélyünk nélkül végrehajtott módosítások következtében jelen nyilatkozat érvényét veszíti.

(PT) Certificado de conformidade da UE

Os abaixo mencionados Lutz-Jesco GmbH, Am Bostelberge 19, 30900 Wedemark, por este meio certificam que ao sair da fábrica o aparelho abaixo mencionado está de acordo com as directrizes harmonizadas da UE, padrões de segurança e de produtos específicos. Este certificado ficará nulo se a unidade for modificada sem a nossa aprovação.

Bezeichnung des Gerätes:	Magnet-Dosierpumpe
Description of the unit:	Solenoid Metering Pump
Désignation du matériel:	Pompe doseuse électromagnétique
Descripción de la mercancía:	Bomba Dosificadora tipo Solenoide
Omschrijving van het apparaat:	Magneetdoseerpomp
A termék megnevezése:	Mágneses adagolószivattyúk
Designação do aparelho:	Bomba doseadora de membrana magnética

Typ / Type	EU-Richtlinie / EU directives	Harmonisierte Normen / harmonized standards
MAGDOS LP 05 – 15	2006/42/EG 2006/95/EG	DIN EN 809:2011-01 DIN EN ISO 12100:2011-03



Lucjan Gogolin
 Leiter Dosiertechnik
 Head of Dosing Department
 Lutz-Jesco, Wedemark, 01.06.2012

Dokumentationsbevollmächtigter:
 Authorized person for documentation:
 Lucjan Gogolin
 Adresse: siehe Adresse des Herstellers
 Address: see manufacturer's address

Lutz-Jesco GmbH
 Am Bostelberge 19
 30900 Wedemark
 Germany

Notes

19 Declaration of harmlessness

Copy the Declaration of harmlessness and complete it separately for each unit. Enclose one copy to the unit you are sending. Please send the declaration of harmlessness to us also in advance per fax or e-mail!

Declaration of Harmlessness

Please fill out a separate form for each appliance!

We forward the following device for repairs:

Device and device type: Part-no.:

Order No.: Date of delivery:

Reason for repair:
.....
.....

Dosing medium

Description: Irritating: Yes No

Properties: Corrosive: Yes No

We hereby certify, that the product has been cleaned thoroughly inside and outside before returning, that it is free from hazardous material (i.e. chemical, biological, toxic, flammable, and radioactive material) and that the lubricant has been drained.

If the manufacturer finds it necessary to carry out further cleaning work, we accept the charge will be made to us.

We assure that the aforementioned information is correct and complete and that the unit is dispatched according to the legal requirements.

Company / address: Phone:

..... Fax:

..... Email:

Customer No.: Contact person:

Date, Signature:

Notes

20 Warranty application

Warranty Application

Please copy and send it back with the unit!

If the device breaks down within the period of warranty, please return it in a cleaned condition with the complete warranty application, filled out.

Sender

Company: Phone: Date:

Address:

Contact person:

Manufacturer order no.: Date of delivery:

Device type: Serial number:

Nominal capacity / nominal pressure:

Description of fault:.....

.....

.....

.....

.....

.....

.....

.....

.....

Service conditions of the device

Point of use / system designation:.....

.....

.....

Accessories used (suction line etc.):.....

.....

.....

.....

.....

Commissioning (date):

Duty period (approx. operating hours):

Please describe the specific installation and enclose a simple drawing of the chemical feed system, showing materials of construction, diameters, lengths and heights of suction and discharge lines.

21 Index

A

Accessories	20
Alarm messages	53
Alarm relay	33
Alarm relay output	29
Analog input	
Connection	28
Operating mode	40
Appropriate and intended use	8

B

Batch mode	44
Batch mode modes	44
Bonded connection	18

C

Calibrating the dosing pump	39
Calibration	39
Cemented conn.	18
Change the diaphragm	50
Clearing the stroke buffer	43
Commissioning	38
Commissioning the dosing pump	38
Connection sockets	27
Contact Water Meter	21
Control	31
Control elements	11

D

Date	33
Declaration of harmlessness	70
Decommissioning the dosing pump	47
Default settings	
List of default settings	66
Delivery capacity data	12
Delivery characteristic curves	55
Device revision	8
Diaphragm	
Spare parts kits	54
Diaphragm rupture	
Configuration of the control unit	34
Diaphragm rupture input	29
Diaphragm rupture sensor	20
Dimensioned drawings	14
Dimensioning of the system	16
Dimensions	14
Disposal of old units	48
Dosing control	
Configuration of the control unit	34
Dosing control input	29
Dosing head	
Aligning the dosing head	17
Spare parts	54
Structure	10
Dosing head venting facility	19

Dosing media

Permitted temperature of the medium	13
Prohibited dosing media	8

E

EC Declaration of Conformity	68
Eco-Mode	
Setting	36
Technical data	12
Electric data	13
Electrical installation	27
Error messages	53
Ethernet connection socket	30
Expert staff	7
Ext. Start (batch mode mode)	44
External On/Off via Release input	47

F

Factory default setting	
Resetting to factory default setting	36
Foreseeable misuse	9
Function description	11

H

Hazards due to non-compliance with the safety instructions	7
Hose clip	17
Hydraulic connections	17
Hydraulic installation	16

I

Information about the dosing pump	37
Initial commissioning	
Menu settings	32
Injection nozzle	20
Inputs of the control unit	27
Installation	15
Electrical	27
Hydraulic	16
Network	30
Installing the Dosing Pump	15
Instructions for action	
Identification	5
Intended purpose	8
Interval (batch mode mode)	44

L

Language	33
Leak sensor	20
Leakage drain	19
Level input	
Configuration of the control unit	33
Connection	29
Level monitoring	24
Explanation of the icons	31

M		Safety code	35
Main menu	32	Scope of delivery	10
Maintenance	49	Set IP address	36
Maintenance intervals	49	Set up information	15
Manual mode	40	Setting the 0/4- 20 mA signal	40
Menu icons	31	Setting the current value for 0 % delivery capacity	41
Menu navigation		Setting the current value for 100 % delivery capacity	41
Explanation	31	Shutdown	47
Menu settings at initial commissioning	32	Shutting down in an emergency	48
Menu structure of the control unit	56	Signal words	
Messages of the control unit	37, 53	Explanation	4
List of all messages	53	Spare parts	54
MODBUS addresses	64	Start/Stop (batch mode mode)	44
N		Storage	48
Nameplate	11	Stroke feedback output	28
Network		Strokes (pulse input mode)	42
Adresses	64	Structure of the dosing pump	10
Installation	30	Suction pressure regulator	23
Network mode	47	Suspensions	25
Notes to the reader	4	System piping	17
O		System setup	32
Operating conditions and limits	12	T	
Operating modes	40	Technical data	12
Explanation of the icons	31	Temperature	
Operation	38	Permitted ambient temperature	12
Operator controls of the control unit	31	Permitted temperature of the medium	13
Output (pulse input mode)	43	Tighten dosing head bolts	50
Outputs of the control unit	27	Time	32
P		Timer (batch mode mode)	45
Personal protective equipment	7	Trained person	7
Personnel qualification	7	Transportation	48
Piping	17	Troubleshooting	51
Pressure control valve	22	U	
Pressure relief valve	21	Units	33
Priming aid	24	User setup	36
Product description	10	V	
Product warranty	8	Venting	39
Programming the dosing procedures	45	Venting the dosing pump	39
Protective equipment		W	
Personal protective equipment	7	Wall assembly	15
Pulsation dampener	23	Wall bracket	15
Pulse input		Warning signs	
Connection	28	Explanation	4
Operating mode	42	Warnings	
Pulse input modes	42	General warnings	6
R		Identification	4
Release code	35	Warranty application	72
Release input		Water meter	21
Configuration of the control unit	34	Water meter (pulse input mode)	43
Connection	28		
Explanation of the icons	32		
S			
Safe operation	7		
Safety	6		



Metering pumps, accessories chlorine gas technology, measuring and control technology, centrifugal pumps, disinfection systems and plant engineering and construction



Products for swimming pool water disinfection based on brine-electrolysis, domestic water systems technology

Lutz-Jesco GmbH
Am Bostelberge 19 • D-30900 Wedemark
www.lutz-jesco.de



Tap and tank pumps, flow meters, double diaphragm pumps, centrifugal pumps

Lutz Pumpen GmbH
P.O. Box 1462 • D-97864 Wertheim
www.lutz-pumpen.de



Head office
Lutz-Jesco GmbH
Am Bostelberge 19
30900 Wedemark
Germany

Tel.: +49 5130 5802-0
Fax: +49 5130 580268

E-mail: info@lutz-jesco.com
Internet: www.lutz-jesco.de

Hungary
Lutz-Jesco Üzletág
Vasvári P. u. 9.
9024 Győr
Hungary

Tel.: +36 96 523046
Fax: +36 96 523047

E-mail: info@lutz-jesco.hu
Internet: www.lutz-jesco.hu

Austria
Lutz-Jesco GmbH
Aredstraße 7/2
2544 Leobersdorf
Austria

Tel.: +43 2256 62180
Fax: +43 2256 6218062

E-mail: info@lutz-jesco.at
Internet: www.lutz-jesco.at

Netherlands
Lutz-Jesco Nederland B.V.
Nijverheidstraat 14 C
2984 AH Ridderkerk
Netherlands

Tel.: +31 180 499460
Fax: +31 180 497516

E-mail: info@lutz-jesco.nl
Internet: www.lutz-jesco.nl

Great Britain
Lutz-Jesco (GB) Ltd.
Gateway Estate
West Midlands Freeport
Birmingham B26 3QD
Great Britain

Tel.: +44 121 782 2662
Fax: +44 121 782 2680

E-mail: info@lutz-jesco.co.uk
Internet: www.lutz-jesco.co.uk

USA
Lutz-JESCO America Corp.
55 Bermar Park
Rochester, N.Y. 14624
USA

Tel.: +1 585 426-0990
Fax: +1 585 426-4025

E-mail: mail@jescoamerica.com
Internet: www.jescoamerica.com

East Asia
Lutz-Jesco East Asia Sdn Bhd
6 Jalan Saudagar U1/16
Hicom Glenmarie Industrial Park
40150 Shah Alam/ Selangor
Malaysia

Tel.: +603 55692322
Fax: +603 55691322

E-mail: info@lutz-jescoasia.com
Internet: www.lutz-jescoasia.com

Middle East
Lutz-Jesco Middle East FZE
P.O. Box 9614
SAIF-Free Zone Center
Sharjah
UAE

Tel.: +971 6 5572205
Fax: +971 6 5572230

E-mail: info@jescome.com
Internet: www.jescome.com