

## MAGDOS LB

Solenoid-driven diaphragm dosing pump



EN

02

## Operation & Maintenance Instructions

Read these operation and maintenance instructions before start up!

To be held for future reference.

# List of Contents

|  |           |
|--|-----------|
| <b>1. Safety</b>   | <b>3</b>  |
| 1.1 General  | 3         |
| 1.2 Warnings used in this Operation & Maintenance Manual             | 3         |
| 1.3 Qualification and training of personnel                          | 3         |
| 1.4 Important safety instructions                                    | 3         |
| 1.5 Hazards due to non-compliance with the safety instructions       | 4         |
| 1.6 Safe operation   | 4         |
| 1.7 Safety instructions for the owner/operator                       | 4         |
| 1.8 Safety instructions for installation, maintenance and inspection | 4         |
| 1.9 Unauthorized modification and production of spare parts          | 4         |
| 1.10 Impermissible modes of operation                                | 5         |
| 1.11 Dosing of Chemicals   | 5         |
| 1.12 Scope of delivery   | 6         |
| <b>2. Compliant use</b>  | <b>7</b>  |
| <b>3. Function</b>   | <b>7</b>  |
| <b>4. Dimensions</b>   | <b>7</b>  |
| <b>5. Technical data</b>   | <b>8</b>  |
| <b>6. Performance curves</b>   | <b>9</b>  |
| <b>7. Installation</b>   | <b>10</b> |
| 7.1 General notes of instruction                                     | 10        |
| 7.2 Installation location  | 10        |
| 7.3 Arrangement of the dosing pump                                   | 10        |
| 7.4 Electrical connection  | 11        |
| 7.5 Hydraulic connections  | 11        |
| 7.6 Injection nozzle installation                                    | 12        |
| 7.7 Installation example/ Example for accessories                    | 12        |
| <b>8. Operation</b>  | <b>13</b> |
| 8.1 Setting of flow rate   | 13        |
| <b>9. Start up</b>   | <b>14</b> |
| <b>10. Shutdown</b>  | <b>15</b> |
| 10.1 Disposal of old equipment                                       | 15        |
| <b>11. Maintenance</b>   | <b>16</b> |
| 11.1 Replacing the diaphragm   | 16        |
| 11.2 Valves  | 17        |
| <b>12. Calibration of the stroke frequency adjustment</b>            | <b>18</b> |
| 12.1 Calibration procedure   | 18        |
| 12.2 Deleting the calibration  | 18        |
| <b>13. Spare part list</b>   | <b>19</b> |
| <b>14. Troubleshooting</b>   | <b>20</b> |
| <b>15. Unit revision</b>   | <b>21</b> |
| <b>16. Index</b>   | <b>22</b> |
| <b>17. Drill template</b>  | <b>23</b> |
| <b>Declaration of conformity</b>                                     | <b>25</b> |
| <b>Declaration of harmlessness</b>                                   | <b>26</b> |
| <b>Warranty Application</b>  | <b>27</b> |

## 1. Safety

### 1.1 General

This Operating & Maintenance Manual contains basic information to be noted during installation, operation and maintenance. It is therefore essential that the Manual be read by the contractor before installing and commissioning the pump/system, as well as by the relevant operating personnel /owner of the unit. It must remain accessible at the dosing pump/system for reference at all times.

In addition to the general safety instructions under this main heading Safety, the special safety precautions outlined in other sections must also be observed.

### 1.2 Warnings used in this Operation & Maintenance Manual

This Operation & Maintenance Manual contains vital information which may endanger people, the environment and the dosing pump/system if they are disregarded. These statements are identified by the following symbols:

#### **DANGER!**

*Refers to an imminent danger.*

*Non-compliance can lead to death or extremely serious injury.*



#### **WARNING!**

*Refers to a potentially hazardous situation. Non-compliance can lead to death or extremely serious injury.*

#### **CAUTION!**

*Refers to a potentially hazardous situation. Non-compliance can lead to minor injury or property damage.*

#### **IMPORTANT! or NOTICE!**

*Appears in conjunction with safety instructions which may endanger the machine and its operation if disregarded.*

#### **IMPORTANT!**

*Draws attention to supplementary information to make the work easier and ensure troublefree operation.*



Markings which are affixed directly to the pump, such as

- Cable markings
- Markings for process fluid connections

must be observed without fail and must remain fully legible at all times.

### 1.3 Qualification and training of personnel

The personnel employed for installation, operation, inspection, and maintenance, must be suitably qualified for this work. The areas of responsibility, competence and supervision of the personnel must be precisely defined by the owner. Personnel who do not have the required know-how must be duly trained and instructed. If necessary, this can also be undertaken by the manufacturer/supplier on behalf of the owner. In addition, the owner of the system must ensure that the relevant personnel are fully familiar with and have understood the contents of this Operation & Maintenance Manual.

### 1.4 Important safety instructions

When installing and using this electrical equipment, basic safety precautions should always be followed, including the following:

#### **NOTICE!**

*Read and follow all instructions!*

*Save these instructions!*



**WARNING!**

To reduce the risk of injury, do not permit children to use this product unless they are closely supervised at all times.

**WARNING!**

*Risk of Electric Shock. Connect only to a grounding type receptacle protected by a ground-fault circuit-interrupter (GFCI). Contact a qualified electrician if you cannot verify that the receptacle is protected by a GFCI. Do not bury cord. Locate cord to minimize abuse from lawn mowers, hedge trimmers, and other equipment.*

**WARNING!**

To reduce the risk of electric shock, replace damaged cord immediately.

**WARNING!**

To reduce the risk of electric shock, do not use extension cord to connect unit to electric supply; provide a properly located outlet.

**1.5 Hazards due to non-compliance with the safety instructions**

Failure to comply with the safety instructions may endanger not only people, but also the environment and the unit. Non-compliance with the safety instructions can lead to the loss of all entitlement to damages.

The following hazards in particular may arise:

- Failure of major unit functions.
- Failure of specified methods for maintenance and repair.
- Danger to people due to electrical, mechanical and chemical effects.
- Danger to the environment due to leakage of hazardous substances.

**1.6 Safe operation**

The safety instructions contained in this Operation & Maintenance Manual must be observed. The owner is responsible for ensuring compliance with local safety regulations.

Disturbances susceptible of impairing safety are to be eliminated immediately!

**1.7 Safety instructions for the owner/operator**

- Leakages (e.g. when a membrane breaks) of dangerous materials to be conveyed (e.g. aggressive, poisonous) must be purged in such a way that they do not become a risk to people and the environment. Statutory regulations must be observed.
- Danger due to electric current must be excluded (for further details, refer to the German VDE<sup>1)</sup> standards as well as local rules and regulations as well as chapter 1.4).

<sup>1)</sup> Association of German Electrotechnical Engineers

**1.8 Safety instructions for installation, maintenance and inspection**

The owner must ensure that all maintenance, inspection and installation work is undertaken by authorized and duly qualified skilled personnel who have also studied this Operation & Maintenance Manual.

The dosing pump must always have come to a complete stop before starting any work on the pump. The procedure specified in the Operation & Maintenance Manual for shutting down the dosing pump/system must be observed without fail.

Dosing pumps or systems in contact with potentially harmful media must be decontaminated.

All safety mechanisms and guards must be refitted and reactivated as soon as the work is complete.

The instructions outlined in chapter 7.2 "Installation location" and 9. "Start up" must be observed before starting the pump/system.

**1.9 Unauthorized modification and production of spare parts**

The device may only be modified or converted in consultation with the manufacturer. Genuine spare parts and accessories authorized by the manufacturer ensure greater safety. The use of other parts can void the liability for the subsequent consequences.

### 1.10 Impermissible modes of operation

Other usage and modifications in opposition to chapter 2 "Appropriate and intended use" will lead to the immediate cancellation of the warranty and any other manufacturer's liability.

### 1.11 Dosing of Chemicals

#### CAUTION!

*When working on dosing systems, the accident prevention regulations applicable on site must be observed and the specified personal protective equipment worn.*

The following standard protective clothing is recommended, depending on the hazard associated with the metered medium:



Protective clothing



Protective gloves



Goggles

All people responsible for installation and maintenance of pumps, piping, hoses and accessories should wear this protective equipment.

Before working on the dosing pump and plant, disconnect it from the mains supply and protect it against reconnection.

#### CAUTION!

*Any chemical still present in the dosing head may spray out when the power supply is reconnected. This may lead to caustic or other burns to the face and hands. Dosing lines must always be connected before starting the pump again.*

The chemical resistance of the pump's materials of construction must be verified before dosing aggressive media!

The dosing head of the dosing pump as well as connections and lines of the system may be under pressure. Working on the dosing plant requires special safety precautions and may only be carried out by instructed technical personnel:

#### CAUTION!

*Chemical could spray out. This may lead to caustic or other burns. Always relieve the pressure before starting work on the dosing pump.*

Before working on the dosing head, valves and connections, flush the dosing pump with a harmless medium (mainly water) to avoid unintentional contact with the metered medium.

#### WARNING!

*Never look into the open end of a clogged line or valve. Chemical may emerge unexpectedly and cause caustic or other burns to face and hands.*

*Before start up, all connections must be inspected for correct tightness and, if necessary, must be tightened up using appropriate tools.*

#### CAUTION!

*If connections at the dosing head are loosened during operation for venting or other reasons, leaking chemical must be removed professionally. This is the only way to avoid the danger of physical injury and corrosion at the dosing pump. Leaking chemical may also damage the diaphragm at its mounting points.*



**NOTICE!**

*When changing the chemical, check whether the pump's and the system's materials are chemically resistant. If there is the danger of a chemical reaction between different media, a thorough cleaning first is mandatory.*

**DANGER!**

*Fire hazard. Pressure surge: parts may burst and cause fatal injury. The equipment may not be used in a highly combustible area under any circumstances.*

**CAUTION!**

*Hot metal parts may burn your hands. Always disconnect the mains power supply before opening the magnetic drive and let the dosing pump cool down for at least one hour.*

**CAUTION!**

*Malfunctions may arise in circuits, magnetic strips or mobile phones if brought into the direct vicinity of the stroking solenoid.*

**1.12 Scope of delivery****IMPORTANT!**

*Please unpack the dosing pump and ordered accessories carefully in order not to miss small parts. Immediately compare the scope of delivery to the delivery note. If there are any discrepancies, contact your local distributor.*



## 2. Compliant use

The product is especially designed for the following purpose: conveyance and dosing of chemicals.

The operational safety of the delivered unit can only be guaranteed when it is used in conformity with its intended use. Other usage and modifications will determine the immediate cancellation of the warranty and any other manufacturer's liability. The operating conditions described in chapter 5 "Technical Data" must be observed!

## 3. Function

Dosing pumps are used to add chemicals specifically in various processes. Metering capacities range from 0.5 to 15 litres per hour. The exact metered capacities can be derived in the chapter "performance curves".

## 4. Dimensions

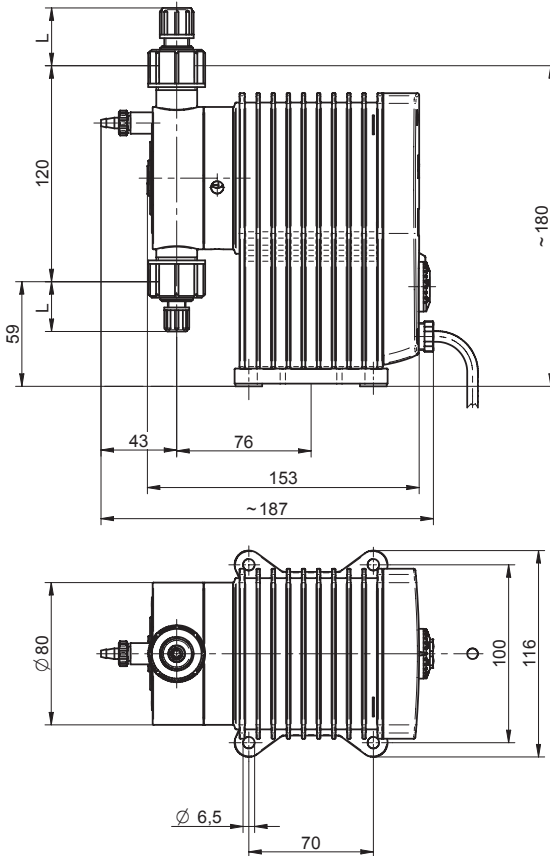

| MAGDOS      | Tube connection with union nut G5/8 | Dim. L |
|-------------|-------------------------------------|--------|
| LB 05 ... 2 | 4/6                                 | 31     |
| LB 4 ... 15 | 6/9, 1/4"-3/8"                      | 34     |
|             | 6/12                                | 15     |

Fig. 4.1: all dimensions in mm.

## 5. Technical data

| MAGDOS                                      | LB 05                                | LB 1                  | LB 2                  | LB 4                  | LB 6     | LB 10    | LB 15                 |
|---|--------------------------------------|-----------------------|-----------------------|-----------------------|----------|----------|-----------------------|
| Diaphragm ø                                 | 24 mm                                |                       | 33 mm                 |                       | 39 mm    |          |                       |
| max. back pressure                          | 16 bar                               | 16 bar                | 16 bar                | 16 bar                | 8 bar    | 6 bar    | 3 bar                 |
| Flow rate at max. pressure *                | 0.36 l/hr                            | 0.75 l/hr             | 1.9 l/hr              | 3.4 l/hr              | 6.2 l/hr | 9.0 l/hr | 13 l/hr               |
| Average back pressure                       | 8 bar                                | 8 bar                 | 8 bar                 | 8 bar                 | 4 bar    | 3 bar    | 1 bar                 |
| Flow rate at medium pressure *              | 0.54 l/hr                            | 1.1 l/hr              | 2.3 l/hr              | 3.8 l/hr              | 6.8 l/hr | 10 l/hr  | 15 l/hr               |
| Max. stroke frequency                       | 120 min <sup>-1</sup>                | 250 min <sup>-1</sup> | 160 min <sup>-1</sup> | 180 min <sup>-1</sup> |          |          | 250 min <sup>-1</sup> |
| Suction lift for non-ef-fervescent media    | 5 mWS                                | 5 mWS                 | 3 mWS                 | 3 mWS                 | 2 mWS    | 2 mWS    | 2 mWS                 |
| Max. inlet pressure                         | 800 mbar                             |                       |                       |                       |          |          |                       |
| Power supply                                | 110 – 240 V AC, -10% / +5%, 50/60 Hz |                       |                       |                       |          |          |                       |
| Power supply cable                          | 1.8 m with mains plug                |                       |                       |                       |          |          |                       |
| Power consumption                           | 18 W                                 |                       |                       |                       |          |          |                       |
| Max. power consumption during dosing stroke | approx. 4 A                          |                       |                       |                       |          |          |                       |
| Protection class                            | IP 65                                |                       |                       |                       |          |          |                       |
| Insulation class                            | F                                    |                       |                       |                       |          |          |                       |
| Weight                                      | approx. 3 kg                         |                       |                       |                       |          |          |                       |
| Max. ambient temperature                    | 45 °C (with PVC parts 40 °C)         |                       |                       |                       |          |          |                       |
| Max. media temperature                      | 50 °C (with PVC parts 35 °C)         |                       |                       |                       |          |          |                       |

\* The exact metered capacities can be derived from the performance curves.

## 6. Performance curves

The performance curves refer to water at 20 °C (68 °F). The performance of the dosing pump depends on the viscosity of the process fluid and hydraulic installation conditions. Dosing pumps must therefore be gauged in litres during application.

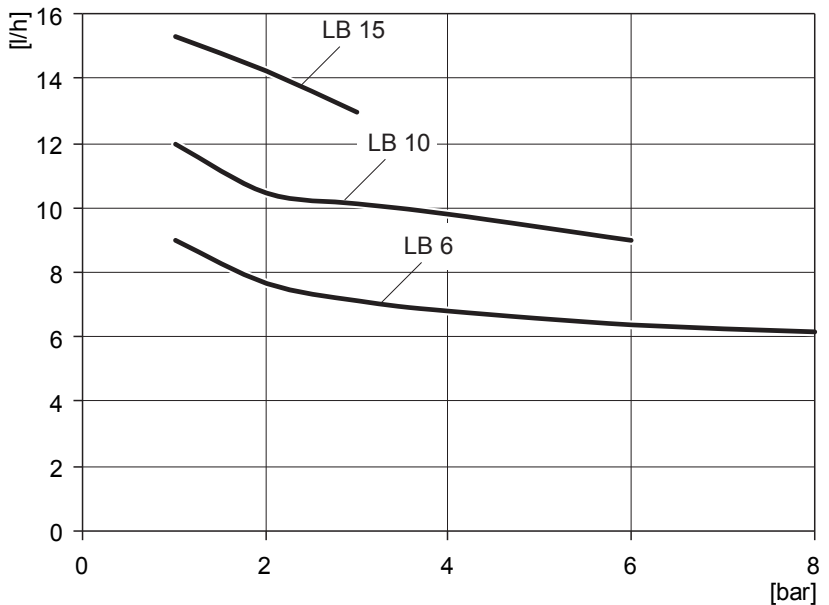
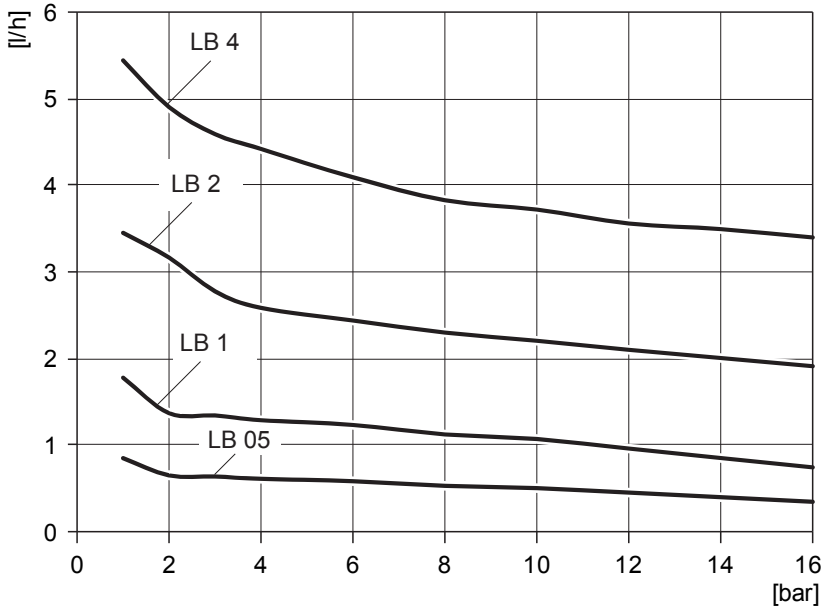

## 7. Installation

### 7.1 General notes of instruction

For the selection of a dosing pump when designing a system as well as for the installation and operation, local rules and regulations must be observed. This applies to the selection of appropriate materials of construction, the handling of the chemicals and the electrical installation. At the same time the technical data of the dosing pump (chapter 5.) must be taken into consideration. The system must be designed accordingly/ properly (e.g. pressure loss in lines depending on nominal diameter and length).

The designer and the user are responsible to make sure that the whole plant including the dosing pump is constructed so that neither plant equipment nor buildings are damaged in the case of chemical leakage due to the failure of wear parts (e.g. diaphragm rupture) or burst tubing. If the chemical plant represents a potential source of danger, the installation must be carried out in a way that no unreasonably high consequential damages occur, even if the dosing pump fails. Therefore we recommend the installation of containment tanks.

The drain outputs of the dosing head must be visible in order for a diaphragm failure to be detected. The flow of the drainage outputs must be on a free downwards gradient if possible.

To increase the dosing accuracy and to ensure the functional reliability, we recommend the use of additional accessories. This includes back pressure valves and relief valves.

Always use appropriate tools for the installation of plastic connecting parts. To avoid damage, never apply excessive force.



#### **IMPORTANT!**

*Plastic parts (especially PVC parts) can be tightened and loosened more easily if the thread is lubricated with slip additive (e.g. silicone grease or PTFE spray).*

#### **NOTICE!**

*The slip additive must be compatible with the chemical to be metered.*



### 7.2 Installation location

The installation location of the dosing pump must be easily accessible for the operating and service staff.

When installing the dosing pump below the storage level of the process fluid, care must be taken to ensure that chemical leakages due to a broken diaphragm cannot cause any damage (collecting pan). It is also possible to mount the pump with a container adapter on the chemical supply tank.

Please note the ambient temperature of the dosing pump (refer to the technical data table). Radiant heat of apparatus and heat exchangers must be shielded so that the dosing pump can still dissipate its own heat sufficiently. Exposure to direct sunlight must be avoided. If the dosing pump is installed outside, provide a roof to protect it against weather.

### 7.3 Arrangement of the dosing pump

The dosing pump can be mounted to the floor but also mounted directly on the wall without additional elements. The dosing head must be turned accordingly (for installation and tightening torque see chapter 11, Maintenance), in order to ensure the flow direction of the medium through the dosing head.

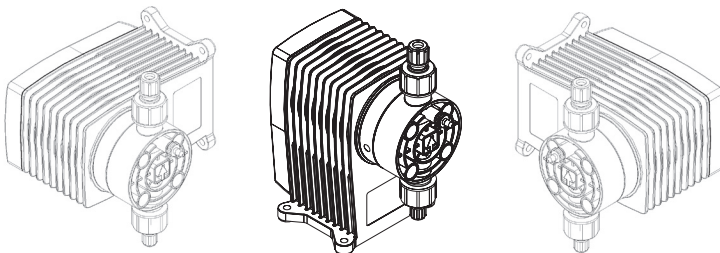

Fig. 7.1: Floor or wall mounting of the dosing pump

## 7.4 Electrical connection

### DANGER!

Fire hazard. Pressure surge: parts may burst and cause fatal injury. The equipment may not be used in a highly combustible area under any circumstances.

The electrical connection of the dosing pump must be made according to the local rules and regulations and may only be carried out by technical personnel.



### NOTICE!

The metering pump has to be plugged into a grounded power outlet.

### NOTICE!

The metering pump is double-insulated and grounded. To avoid incorrect metering after the process is finished, the dosing pump must be locked electrically and hydraulically.



## 7.5 Hydraulic connections

The MAGDOS LB is delivered with loose hose connections. The tubings to the pump may not be under pressure and must be equipped with a tension safeguard. Cut the tubing neatly and in an exact right angle to the appropriate length. Choose the tubing connection according to the character of the tubing (material, inner diameter, wall thickness) in order to considerate the maximum pressure load.

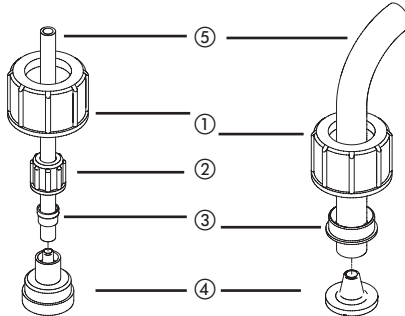

Fig. 7.2: Example 4/6 tubing connection      Example 6/12 tubing connection

To mount the union nuts ①/② and the clamping ring ③, pull them onto the tube ⑤. Then push the tube as far as it will go on the connection ④. Tighten the union nut ②. Place the connection ④ with the gasket to the dosing head and tighten it with the union nut ①.

When connecting the tubing connections observe the flow direction and the horizontal positioning of the dosing head. The dosing head is marked with an arrow ⑦. The suction line ⑧ must always point to the bottom. Consequently the arrow ⑦ and the pressure line ⑥ always point to the top. This is irrespective from the positioning of the dosing head to the drive (see fig. 7.1).

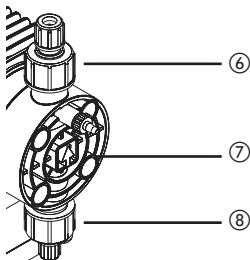

Fig. 7.3: Dosing head flow direction

## 7.6 Injection nozzle installation

Injection nozzles are used to mix the metered process fluid into a main stream and simultaneously fulfill a non-return function. The injection nozzle is usually installed in the main line from above. Installation from below is only recommended in the case of media with a tendency to crystallize. Thus entrapped air is able to leave.

In the case of media with a tendency to contaminate the injection nozzle, it is advisable to use an injection nozzle which can be dismantled for maintenance and shut off.

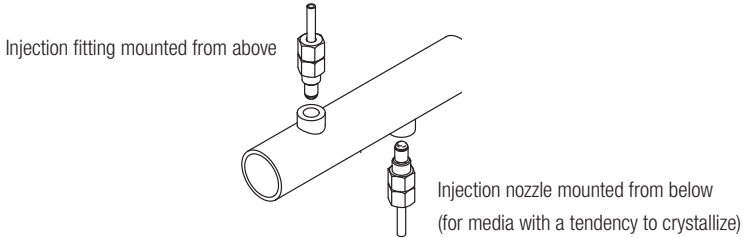

Fig. 7.4: Injection nozzle installation

## 7.7 Installation example/ Example for accessories

Excerpt of the comprehensive metering technology accessory program of the manufacturer.

Mounting of the MAGDOS LB on a container with a container adapter.

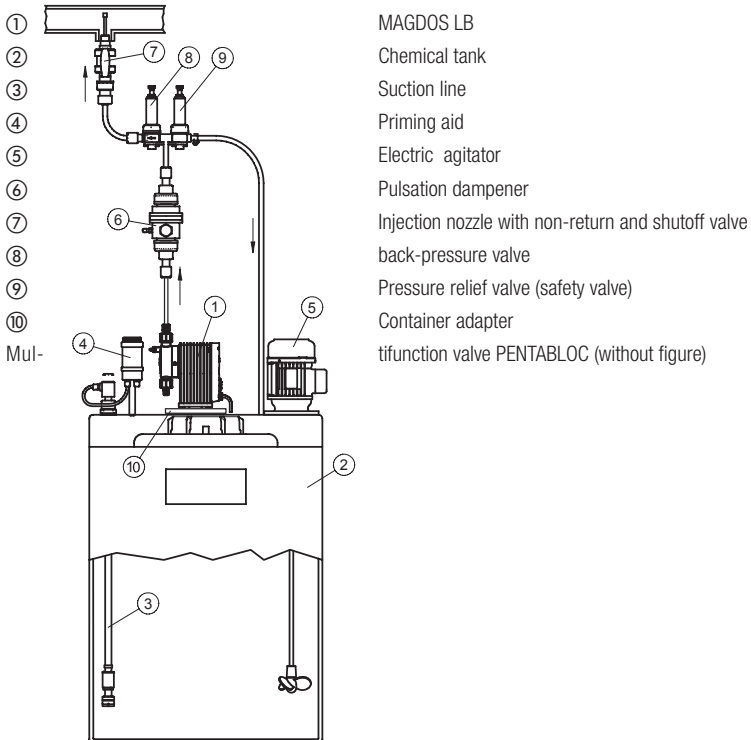

Fig. 7.5: Example of installation of a dosing pump with accessories

## 8. Operation

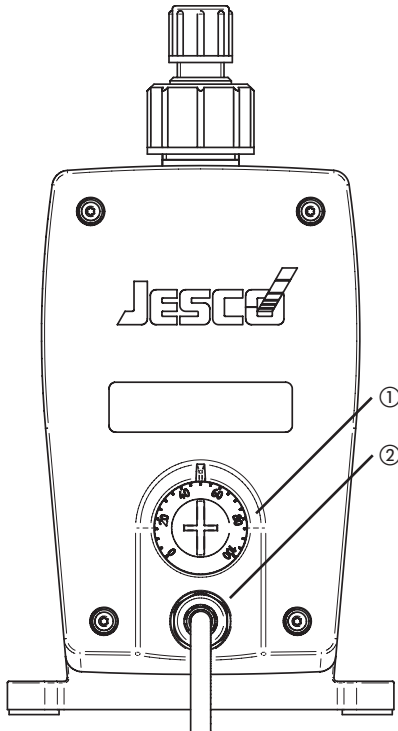

Fig. 8.1: Control panel MAGDOS LB with ① stroke frequency adjustment with dial, ② power cable

The dosing pump has no on/off-switch and is operated externally via the power supply. To stop the dosing pump, the power supply must be interrupted, or the metering capacity must be adjusted by turning the stroke frequency dial to the right to "0 %".

### 8.1 Setting of flow rate

In dependence to the model variant, the dosing pump has a fixed stroke length and a fixed dosing quantity per stroke. The dosing quantity is controlled continuously variable via the stroke frequency in the metering capacity of 0 to 100% (see stroke frequency adjustment ①). The stroke frequency adjustment is approximately linear in proportion to the conveyed dosing quantity. For the maximum dosing quantity (100% metering capacity) in dependence of the back pressure refer to the flow rate characteristics. The maximum and the medium capacity are also indicated on the type plate of the dosing pump.

The actual metering capacity in the respective surroundings may differ from the theoretical capacity. The stroke frequency adjustment may be adapted by a calibration process to the surrounding (see chapter 12).

## 9. Start up



### CAUTION!

Personal protective equipment as specified by the applicable accident prevention regulations must be worn during all work on the dosing pump/system!



Protective clothing



Protective gloves



Goggles

The start-up may only take place after the installation was completed (see chapter 7). All lines must be connected pressure-resistant.



### WARNING!

Chemical could spray out. This may lead to caustic or other burns. Ensure that the discharge line is pressureless before disconnecting it.

1. For the first start-up, set the pump to 100% stroke frequency and allow the pump to prime. Priming aid is recommended. (Refer to installation examples, Chapter 7.7)
2. Open the vent screw in the dosing head while the dosing pump is switched on until fluid comes out. Then close it again. In the case of effervescent media, allow the liquid to escape permanently (approx. 1 drop for 1...3 strokes). The escaping chemical must be returned to the supply tank with the aid of a hose connector.
3. When correct operation is achieved, set desired flow rate. For a rough estimation, please refer to the performance ratings on the type plate of the dosing pump. Intermediate values must be acquired.



### NOTICE!

Depending on the installation, the chemicals used and the temperature of the process fluid, these values may differ and must be checked under operating conditions.

The manufacturer of the dosing equipment is not responsible for damages due to excessive or low flow rates resulting from faulty dosing pump settings or insufficient and incorrect installation of peripheral accessories.



Abb. 9.1: ① Vent screw, automatic dosing head vent valve

## 10. Shutdown

Before starting any maintenance and before prolonged downtime, drain the chemical from the dosing pump and rinse it thoroughly with a neutral medium.

### CAUTION!

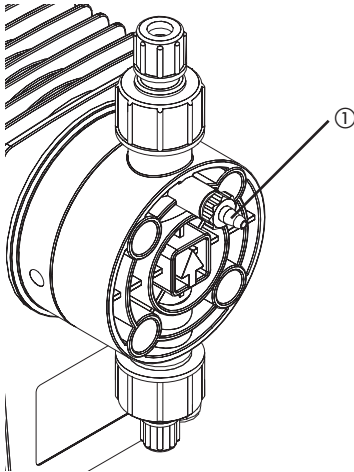
*Excess chemical must be disposed of in accordance with local rules and regulations. Note the applicable accident prevention regulations and wear personal protective equipment.*



Protective clothing



Protective gloves



Goggles

### CAUTION!

*The dosing pump must be disconnected from the power supply and secured to prevent unauthorized restarting.*



### CAUTION!

*The pressure must be relieved before disconnecting the discharge line from the pump discharge valve so that chemical cannot be sprayed out.*



### 10.1 Disposal of old equipment

If the equipment is to be disposed of, it has to be thoroughly rinsed. Excess chemicals must be disposed of in accordance with local rules and regulations. The equipment is manufactured allowing for the ROHS guideline and the old electrical equipment law. The manufacturer takes care of the disposal if the equipment is sent back free of charge. It is not part of domestic waste.

## 11. Maintenance

Dosing pumps are produced according to the highest quality standards and have a long service life. Nevertheless some parts are subject to wear caused by operation (e.g. diaphragm, valve seats, valve balls). To ensure a long operating life, visual inspections are recommended regularly. Periodic maintenance protects the dosing pump and system from unexpected downtime. The manufacturer recommends an annual maintenance if local valid regulations do not stipulate more frequent maintenance.



### NOTICE!

*Before working on the dosing head, valves and connections, flush the dosing pump with a harmless medium (mainly water) to avoid unintentional contact with the metered medium.*



### NOTICE!

*After replacing the diaphragm or other spare parts it might become necessary to gauged in litres, readjust or calibrate (stroke frequency) the dosing pump.*

### 11.1 Replacing the diaphragm



### CAUTION!

*Chemical could spray out. This may lead to caustic or other burns. The dosing pump head must always be depressurized and rinsed thoroughly with water or a suitable medium before starting any work on the dosing pump.*

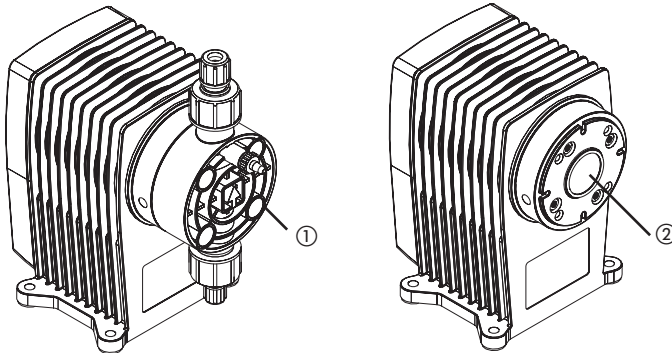

### Replacing the diaphragm

#### IMPORTANT!

*Do not continue before having disconnected the power supply of the pump.*

Remove the dosing head ① by loosening the four dosing head screws with a suitable tool (Allen wrench SW 3).

Bend the diaphragm edge ② slightly up, grip it with pliers and unscrew it anticlockwise.

#### IMPORTANT!

*The diaphragm section of the dosing pump must be cleaned to remove any chemical before fitting a new diaphragm, otherwise the diaphragm may be attacked from the rear.*

Apply some grease (for example Molykote Longterm W2) to the thread of the new diaphragm. The new diaphragm is turned clockwise manually until it sits close in the diaphragm rod.

Fit the dosing head at the front. Insert all four dosing head screws and tighten them lightly. After this tighten the screws alternately, e.g. top left – bottom right – top right – bottom left. A tightening torque of 180 Ncm is required for the dosing head screws.

**IMPORTANT!**

*The diaphragm will not provide a tight seal if the tightening torque is too low. The dosing head may be damaged if the tightening torque is too high.*

The dosing pump is started as described in the section Start-up (Chapter 9) after connecting the dosing lines. If the diaphragm is frequently worn down, refer to the section "Troubleshooting" (Chapter 14) for a description of possible causes.

**11.2 Valves**

Check the double-ball valves of the dosing pumps regularly for impurities. A valve is replaced by replacing the complete dosing head.

**CAUTION!**

*Chemical could spray out. This may lead to caustic or other burns. The dosing pump must always be depressurized and rinsed with water or a suitable medium before starting any work on the dosing pump.*

**NOTICE!**

*Debris in the check valves will reduce the dosing accuracy.*



## 12. Calibration of the stroke frequency adjustment

The maximum performance of the pump was calibrated by the manufacturer under standard conditions. In operation the performance may differ according to the surroundings and the medium. The operator may therefore adapt the performance of the pump to the actual flow rate.

### 12.1 Calibration procedure

1. After installation and start-up of the pump, take the suction line out of the dosing container and put it into a priming aid containing the same medium.
2. In order to ventilate the dosing pump and the line, operate the dosing pump until no bubbles are left in the lines. Then switch off the dosing pump.
3. Fill up the priming aid again and mark the fluid level.
4. Turn the stroke frequency dial to the right ( $< 0\%$ ).
5. Adjust the required flow rate as follows:
  - 5.1 Switch on the dosing pump and after 1 s turn the dial within 5 s right to the left ( $> 100\%$ ).
  - 5.2 Within 5 s turn it to the right ( $< 0\%$ ).
  - 5.3 Within 5 s adjust it to the required flow rate (Target %).

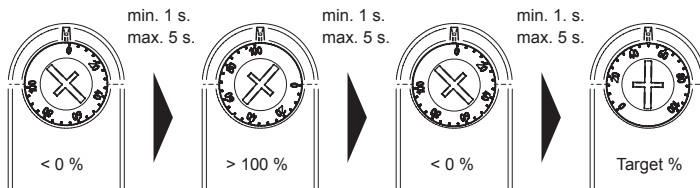

(If one of the steps takes longer than 5 s, no calibration takes place and the dosing pump starts). The required flow rate can be calculated via the maximum performance of the dosing pump. Example: 15 l/h = max. performance of the dosing pump, 9 l/h = required performance -->  $9/15 = 60\%$ .

6. The dosing pump will start operating for 60 s and will then stop automatically. Then switch off the dosing pump.
7. Fill up the quantity that was conveyed from the priming aid with a measuring glass to the marked fluid level.
8. The quantity in ml or  $\text{cm}^3$  filled up from the measuring glass corresponds with the dosing quantity. The actual flow rate of the maximum performance in % can now be calculated. This means: actual flow rate [%] = quantity taken out \* 6 / max. performance of the dosing pump. (Example: 15 l/h = max. performance of the dosing pump, 180 ml = quantity taken out in 60 s --> actual flow rate =  $180 * 6 / 15 = 72\%$ )
9. Put the suction line back into the container.
10. Turn the stroke frequency dial to the right ( $< 0\%$ ).
11. Switch on the dosing pump and after 1 s turn the dial within 5 s right to the left ( $> 100\%$ ).
12. Within 5 s turn it to the right ( $< 0\%$ ).
13. Adjust it within 5 s to the calculated, actual flow rate (ACTUAL %).

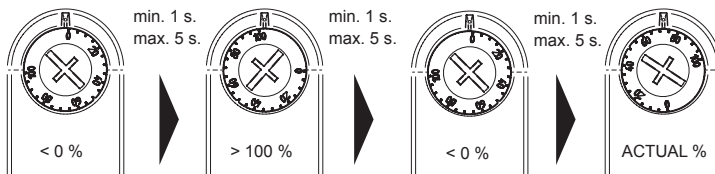

14. The pump will calibrate automatically to the new value.

### 12.2 Deleting the calibration

- Turn the stroke frequency dial to the right ( $< 0\%$ ) while the dosing pump is switched off.
- Switch on, after 1 second turn the stroke frequency dial within 5 s to the left ( $> 100\%$ ). Within 5 s turn it to the right ( $< 0\%$ ) and then turn it to the left ( $> 100\%$ ).

After switching on/off the dosing pump once, it is back in delivery status.

### 13. Spare part list

#### Diaphragm with dosing head screws

| Material    | Part-no. for pump dimension |      |         |      |         |       |       |
|-------------|-----------------------------|------|---------|------|---------|-------|-------|
|             | LB 05                       | LB 1 | LB 2    | LB 4 | LB 6    | LB 10 | LB 15 |
|             | d 24 mm                     |      | d 33 mm |      | d 39 mm |       |       |
| PTFE-coated | 39121                       |      | 39122   |      | 39123   |       |       |

#### Dosing head including valves and dosing head screws

| Material | Valves          |      | Gas-kets | Part-no. for pump dimension |       |         |      |         |       |
|----------|-----------------|------|----------|-----------------------------|-------|---------|------|---------|-------|
|          |                 |      |          | LB 05                       | LB 1  | LB 2    | LB 4 | LB 6    | LB 10 |
|          | Ball            | Seat |          | d 24 mm                     |       | d 33 mm |      | d 39 mm |       |
| PVC      | Glass           | PVDF | FPM      | 38981                       | 38982 | 38983   |      |         |       |
|          | PTFE            | PVDF |          | 39081                       | 39082 | 39083   |      |         |       |
|          | Stainless steel |      |          | 39087                       | 39088 | 39089   |      |         |       |
|          | Glass           | PVDF | EPDM     | 39042                       | 39043 | 39044   |      |         |       |
|          | PTFE            | PVDF |          | 39096                       | 39097 | 39098   |      |         |       |
|          | Stainless steel |      |          | 39102                       | 39103 | 39104   |      |         |       |
| PP       | Glass           | PVDF | FPM      | 38978                       | 38979 | 38980   |      |         |       |
|          | PTFE            | PVDF |          | 39084                       | 39085 | 39086   |      |         |       |
|          | SS              | SS   |          | 39090                       | 39091 | 39092   |      |         |       |
|          | Glass           | PVDF | EPDM     | 39045                       | 39046 | 39047   |      |         |       |
|          | PTFE            | PVDF |          | 39099                       | 39100 | 39101   |      |         |       |
|          | Stainless steel |      |          | 39105                       | 39106 | 39107   |      |         |       |
| PVDF     | Glass           | PVDF | FPM      | -                           | -     | -       |      |         |       |
|          | PTFE            | PVDF |          | 38984                       | 38985 | 38986   |      |         |       |
|          | Stainless steel |      |          | 39093                       | 39094 | 39095   |      |         |       |
|          | Glass           | PVDF | EPDM     | -                           | -     | -       |      |         |       |
|          | PTFE            | PVDF |          | 39048                       | 39049 | 39050   |      |         |       |
|          | Stainless steel |      |          | 39108                       | 39109 | 39110   |      |         |       |

## 14. Troubleshooting

| Problem   | Possible cause   | Recommended Action   |
|---|--|--|
| Dosing pump not delivering or output too low.     | Check valves leaking or blocked.   | Clean check valves and bleed dosing head.<br>See also "start up".  |
|   | Suction valve or suction line leaking or blocked.                                | Clean or seal suction line.  |
|   | Suction lift too high.   | - Install dosing pump at lower position.<br>- Install pulsation dampener on suction side.<br>- Install priming aid.  |
|   | Viscosity too high   | - Enlarge suction and discharge line/diameter.<br>- Use special dosing head<br>>> Contact manufacturer   |
| No stroke movement observed                       | Stroke length set to zero.   | Correctly adjust pump stroke frequency.  |
|   | Diaphragm return spring broken.  | inform Lutz-Jesco service.   |
|   | Fuse blown.  | Check power supply voltage, contact service.   |
|   | Power supply interrupted   | Switch on power supply voltage.  |
|   | Solenoid defective.  | inform Lutz-Jesco service.   |
| Frequent diaphragm failures                       | Diaphragm was not properly tightened to the diaphragm rod.                       | Screw in new diaphragm.  |
|   | System back pressure too high. (measured at discharge connection of dosing pump) | Inspect system. Clean blocked injection nozzle. Reduce pressure spikes resulting from extremely long tubes by installing pulsation dampeners. Check function of safety valves. |
|   | Media sediment in dosing head.   | Flush dosing head.   |
| Dosing Pump delivering too much. (Pump siphoning) | Pressure on suction side too high.   | Install back pressure valve or suction controller.   |

If the problem cannot be solved with the support of the above instructions, contact our After-Sales Service for further assistance or return dosing pump to manufacturer. Repairs will be carried out immediately.

## 15. Unit revision

This operation manual apply to following units:

| Unit      | Year of manufacture | Firmware |
|-----------|---------------------|----------|
| MAGDOS LB | 05/2009             | 2.03     |

It contains all the technical information required for installation, start-up and maintenance. Should you have any questions or require further informations regarding these operating instructions, please contact the manufacturer or its official national representative.

## 16. Index

|                                      |    |                                     |    |
|--------------------------------------|----|-------------------------------------|----|
| <b>A</b>                             |    | <b>M</b>                            |    |
| Accessories .....                    | 12 | Maintenance .....                   | 16 |
| Agitator .....                       | 12 | <b>O</b>                            |    |
| Arrow .....                          | 11 | Operation .....                     | 13 |
| <b>B</b>                             |    | <b>P</b>                            |    |
| Back pressure regulating valve ..... | 12 | Performance curves .....            | 9  |
| <b>C</b>                             |    | Personal protection equipment.....  | 14 |
| Calibration .....                    | 18 | Positioning of the dosing pump..... | 10 |
| Chemical tank.....                   | 12 | Pressure relief valve .....         | 12 |
| Compliant use.....                   | 7  | Priming aid.....                    | 12 |
| <b>D</b>                             |    | Problem .....                       | 20 |
| Declaration of conformity .....      | 25 | Protective clothing.....            | 5  |
| Declaration of harmlessness.....     | 26 | Pulsation dampener .....            | 12 |
| Delivery capacity.....               | 14 | <b>R</b>                            |    |
| Dimensions .....                     | 7  | Replacing the diaphragm.....        | 16 |
| Dosing accuracy .....                | 10 | <b>S</b>                            |    |
| dosing head vent valve .....         | 14 | Shutdown .....                      | 15 |
| Dosing of Chemicals .....            | 5  | Spare part list.....                | 19 |
| Double-ball valves.....              | 17 | Start up.....                       | 14 |
| Drill template .....                 | 23 | System consideration .....          | 10 |
| <b>E</b>                             |    | <b>T</b>                            |    |
| Electrical connection .....          | 11 | Technical data .....                | 8  |
| Example for accessories.....         | 12 | Troubleshooting .....               | 20 |
| <b>F</b>                             |    | Tubing connection.....              | 11 |
| Function.....                        | 7  | <b>V</b>                            |    |
| <b>H</b>                             |    | Valves .....                        | 17 |
| Hydraulic connections .....          | 11 | Vent screw .....                    | 14 |
| <b>I</b>                             |    | Vent valve.....                     | 14 |
| Initial start-up .....               | 14 | <b>W</b>                            |    |
| Injection nozzle .....               | 12 | Wall mount.....                     | 10 |
| Injection nozzle installation .....  | 12 | Warranty Application .....          | 27 |
| Installation .....                   | 10 |                                     |    |
| Installation examples.....           | 12 |                                     |    |
| Installation location .....          | 10 |                                     |    |

## 17. Drill template

Scale 1:1

All dimensions in mm

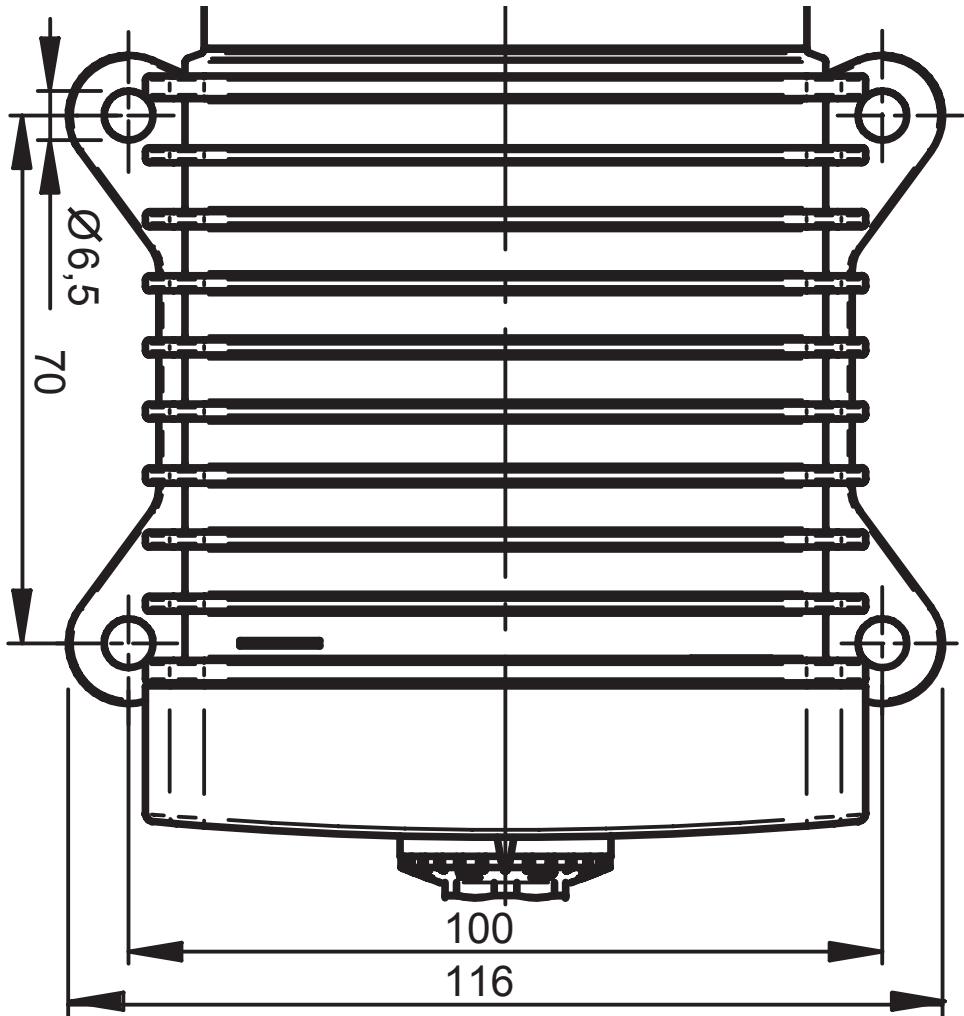



#### EG-Konformitätserklärung

Der Unterzeichnete Lutz-Jesco GmbH, Am Bostelberge 19, 30900 Wedemark, bestätigt, dass die nachfolgend bezeichneten Geräte in der von uns in Verkehr gebrachten Ausführung die Anforderungen der harmonisierten EU-Richtlinien, EU-Sicherheitsstandards und produktspezifischen Standards erfüllen. Bei einer nicht mit uns abgestimmten Änderung der Geräte verliert diese Erklärung ihre Gültigkeit.

#### (EN) EU Certificate of Conformity

The undersigned Lutz-Jesco GmbH, Am Bostelberge 19, 30900 Wedemark, hereby certifies that, when leaving our factory, the units indicated below are in accordance with the harmonised EU guidelines, EU standards of safety and product specific standards. This certificate becomes void if the units are modified without our approval.

#### (FR) Certificat de conformité aux directives européennes

Le constructeur, soussigné: Lutz-Jesco GmbH, Am Bostelberge 19, 30900 Wedemark, déclare qu'à la sortie de ses usines le matériel neuf désigné ci-dessous était conforme aux prescriptions des directives européennes énoncées ci-après et conforme aux règles de sécurité et autres règles qui lui sont applicables dans le cadre de l'Union européenne. Toute modification portée sur ce produit sans l'accord express de Jesco supprime la validité de ce certificat.

#### (ES) Declaración de conformidad de la UE

El que suscribe Lutz-Jesco GmbH, Am Bostelberge 19, 30900 Wedemark, declara que la presente mercancía, objeto de la presente declaración, cumple con todas las normas de la UE, en lo que a normas técnicas, de homologación y de seguridad se refiere. En caso de realizar cualquier modificación en la presente mercancía sin nuestra previa autorización, esta declaración pierde su validez.

#### (NL) EU-overeenstemmingsverklaring

Ondergetekende Lutz-Jesco GmbH, Am Bostelberge 19, 30900 Wedemark, bevestigt, dat het volgende genoemde apparaat in de door ons in de handel gebrachte uitvoering voldoet aan de eis van, en in overeenstemming is met de EU-richtlijnen, de EU-veiligheidsstandaard en de voor het product specifieke standaard. Bij een niet met ons afgestemde verandering aan het apparaat verliest deze verklaring haar geldigheid.

#### (HU) EG (EK)– Egyezőségi nyilatkozat

A Lutz-Jesco GmbH, Am Bostelberge 19, 30900 Wedemark ezúton kijelenti, hogy a szóban forgó termék annak tervezése és szerkezeti módja, valamint forgalomba hozott kivitele alapján a vonatkozó alapvető biztonságtechnikai és egészségügyi követelményeknek és az alábbi felsorolt EG –irányelveknek minden szempontból megfelel. A terméken engedélyünk nélküli végrehajtott módosítások következtében jelen nyilatkozat érvényét veszíti.

#### (PT) Certificado de conformidade da UE

Os abaixo mencionados Lutz-Jesco GmbH, Am Bostelberge 19, 30900 Wedemark, por este meio certificam que ao sair da fábrica o aparelho abaixo mencionado está de acordo com as directrizes harmonizadas da UE, padrões de segurança e de produtos específicos. Este certificado ficará nulo se a unidade for modificada sem a nossa aprovação.

|                                |  |
|--------------------------------|--|
| Bezeichnung des Gerätes:       | <b>Magnet-Dosierpumpe</b>                |
| Description of the unit:       | <b>Solenoid Metering Pump</b>            |
| Désignation du matériel:       | <b>Pompe doseuse électromagnétique</b>   |
| Descripción de la mercancía:   | <b>Bomba Dosificadora tipo Solenoide</b> |
| Omschrijving van het apparaat: | <b>Magneetdosserpomp</b>                 |
| A termék megnevezése:          | <b>Mágneses adagolószivattyúk</b>        |
| Designação do aparelho:        |  |

Typ / Type / Tipo / Típusjelölés:

**MAGDOS LB**

EU-Richtlinie / EU directives/  
Directives européennes / Normativa UE /  
EU-richtlijnen / Vonatkozó EG-irányelvek /  
Directrizes da UE

**2006/95/EG**  
**2006/42/EG**  
**2004/108/EG**

Harmonisierte Normen / harmonized  
standards / Normes harmonisées /  
Estándares acordemente / Toegepaste normeringen /  
Hatályos normák / Normas harmonizadas

**EN 55014-1 : 2006**  
**EN 55014-2 : 1997**  
**EN 61000-3-3 : 2005**  
**EN 61000-6-2 : 03.2006**  
**EN 61000-6-3 : 06.2005**  
**EN ISO 12100-1 : 2003**  
**EN ISO 12100-2 : 2003**  
**EN 809 : 1998**



Lucjan Gogolin  
Lutz-Jesco, Wedemark, 02.05.2009

Leiter Dosiertechnik  
Director Dosing Technology

Dokumentation / documentation / documentación /  
documentação / dokumentációt / documentatie:  
Lucjan Gogolin

## Declaration of harmlessness

Please copy and send with and fill out for each device!

### Declaration of harmlessness

(please fill out a separate form for each appliance)

We forward the following device for repairs:

Device and device type: .....

Part-no.: .....

Order No.: .....

Date of delivery: .....

Reason for repair: .....

#### Chemical metered:

Description .....

Properties:.....

Irritating:                      Yes/No\*)                      Corrosive:    Yes/No\*)

\*) If not applicable please cross out!

We hereby certify, that the product has been cleaned thoroughly inside and outside before returning, that it is free from hazardous material (i.e. chemical, biological, toxic, flammable, and radioactive material) and that the lubricant has been drained. \*)

If the manufacturer find it necessary to carry out further cleaning work, we accept the charge will be made to us.

We assure that the aforementioned information is correct and complete and that the unit is dispatched according to the legal requirements.

Company:.....

Address:.....

.....

.....

Phone: .....

Fax:.....

E-Mail: .....

Customer No.: .....

Contact person: .....

Date, Signature.....

## Warranty Application

Please copy and send it back with the unit!

If the device breaks down within the period of warranty, please return it in a cleaned condition with the complete warranty application, filled out.

---

Sender

Company:..... Phone:..... Date:.....

Address:.....

Contact person: .....

Manufacturer order-no.: ..... Date of delivery: .....

Device type:..... Serial number:.....

Nominal delivery capacity / nominal pressure:.....

Description of fault: .....

.....  
.....

---

Type of fault:

1. Mechanical fault

Premature wear

Wear parts

Breakage / other damage

Corrosion

Damage in transit

2. Electrical fault

Connections, plug connectors or cables loose

Operating elements (e.g. switches / push-buttons)

Electronic unit

3. Leaks

Connections

Dosing head

4. No or inadequate function

Diaphragm defective

Other

---

Service conditions of the device

Point of use / system designation:.....

Accessories used (Suction line, etc.):.....

.....  
.....

Commissioning (date):.....

Duty period (approx. operating hours): .....

Please describe the specific installation and enclose a simple drawing of the chemical feed system, showing materials of construction, diameters, lengths and heights of suction and discharge lines.



## Lutz-Jesco GmbH

Am Bostelberge 19  
30900 Wedemark  
Germany

Phone: +49 5130 5802-0  
Fax: +49 5130 580268  
info@lutz-jesco.com  
www.lutz-jesco.com/de

## Austria

Lutz-Jesco GmbH  
  
Aredstraße 7/2  
2544 Leobersdorf  
Austria

Phone: +43 2256 62180  
Fax: +43 2256 6218062  
E-Mail: info@lutz-jesco.at  
Internet: www.lutz-jesco.at

## USA

Lutz-JESCO America Corp.  
  
55 Bermar Park  
Rochester, NY 14624  
USA

Phone: +1 585 426-0990  
Fax: +1 585 426-4025  
E-Mail: mail@jescoamerica.com  
Internet: www.jescoamerica.com

## Great Britain

Lutz-Jesco (GB) Ltd.  
  
Gateway Estate  
West Midlands Freeport  
Birmingham B26 3QD  
Great Britain

Phone: +44 121 782 2662  
Fax: +44 121 782 2680  
E-Mail: info@lutz-jesco.co.uk  
Internet: www.lutz-jesco.co.uk

## East Asia

Lutz-Jesco  
East Asia Sdn Bhd  
6 Jalan Saudagar U1/16  
Hicom Glenmarie Industrial Park  
40150 Shah Alam /Selangor  
Malaysia

Phone: +603 5569 2322  
Fax: +603 5569 1322  
E-Mail: info@lutz-jescoasia.com  
Internet: www.lutz-jescoasia.com

## Netherlands

Lutz-Jesco Nederland B.V.  
  
Nijverheidstraat 14 C  
2984 AH Ridderkerk  
Netherlands

Phone: +31 180 499460  
Fax: +31 180 497516  
E-Mail: info@lutz-jesco.nl  
Internet: www.lutz-jesco.nl

## Middle East

Lutz-Jesco Middle East FZE  
  
P.O. Box 9614  
SAIF-Free Zone Center  
Sharjah  
UAE

Phone: +971 6 5572205  
Fax: +971 6 5572230  
E-Mail: info@jescome.com  
Internet: www.jescome.com

## Hungary

Lutz-Jesco Üzletág  
  
Vasvári P. u. 9.  
9024 Győr  
Hungary

Phone: +36 96 523046  
Fax: +36 96 523047  
E-Mail: info@lutz-jesco.hu  
Internet: www.lutz-jesco.hu



Best.-Nr. BA-10211-02-V06  
Subject to technical changes  
© Lutz-Jesco GmbH 06.2014  
Printed in Germany