

EASYCHLORGEN

Operating instructions



Read the operating manual!

The user is responsible for installation and operation related mistakes!

List of Contents

1	Notes for the Reader	4	10.3	Remote Inhibit	28
1.1	General non-discrimination	4	10.4	Softener Regeneration	28
1.2	Explanation of the signal words	4	10.5	Replace Water Softener Cartridge	29
1.3	Explanation of the warning signs	4	10.6	Emergency Shutdown	29
1.4	Identification of warnings	4	10.7	Record Log of Operation	29
1.5	Instruction for action identification	5			
1.6	References to intellectual property rights	5	11	Shutdown	30
1.7	Details for the operator	5	11.1	Short-term shutdown (up to 6 months)	30
1.8	Instruction & training course assistance	5	11.2	Long-term shutdown	30
1.9	Example of training course topics	5	11.3	Storage	30
			11.4	Transportation	30
2	Safety	6	11.5	Disposal of old equipment	30
2.1	General warnings	6	12	Maintenance	31
2.2	Hazards due to non-compliance with the safety instructions	6	12.1	Maintenance Intervals	31
2.3	Working in a safety-conscious manner	6	12.2	Electrolyser cleaning	33
2.4	Personal protective equipment	7	12.3	Finishing maintenance	33
2.5	Personnel qualification	7	13	Troubleshooting	35
3	Intended Use	8	14	Spare Parts	36
3.1	Notes on product warranty	8	14.1	Recommended spare parts	36
3.2	Intended purpose	8	14.2	Maintenance sets	36
3.3	Device revision	8	15	EC conformity/declaration of incorporation	37
3.4	Sodium Chloride Chemical Specification	8	16	Declaration of no objection	39
3.5	Water Quality	9	17	Warranty Application	41
3.6	Standard warranty conditions	9	Index		43
4	Product description	10			
4.1	Scope of delivery	10			
4.2	Design and function	10			
5	Technical data	13			
5.1	Output data	13			
5.2	Operating conditions and limits	13			
5.3	Electrical specifications	14			
5.4	Connection dimensions	14			
5.5	Components coming into contact with the media	14			
5.6	Other data	14			
6	Dimensions	15			
6.1	EASYCHLORGEN Compact Modular	15			
6.2	EASYCHLORGEN Compact SKID-1	15			
6.3	EASYCHLORGEN Compact SKID-2	15			
7	Installation	16			
7.1	Installation location	16			
7.2	Hydraulic installation	17			
7.3	Electrical installation	19			
7.4	Installation schematics	21			
8	Control	25			
8.1	Control display	25			
9	Start-up	26			
9.1	Turning on the system	26			
9.2	Commissioning the system	26			
10	Operation	28			
10.1	Automatic Operation	28			
10.2	Manual Inhibit	28			

1 Notes for the Reader

This operating manual provides significant assistance in the successful and smooth running of the EASYCHLORGEN Compact 25/ 50/ 100 electrolysis systems, also referred to, in short, as “system” in the following instructional text.

The operating manual for the EASYCHLORGEN Compact 25/ 50/ 100 electrolysis systems must always be available where the system is located and it has to be read and used by every person who is assigned to working on the system. This includes amongst other things:

- the installation
- the servicing and repair work
- the maintenance (maintenance, care, repair)
- the transport

1.1 General non-discrimination

In this operating manual, only the male gender is used where grammar allows gender allocation. The purpose of this is to make the text clearly legible. Men and women are always referred to equally. We would like to ask female readers for understanding of this text simplification.

1.2 Explanation of the signal words

Different signal words in combination with warning signs are used in this operating manual. Signal words illustrate the gravity of possible injuries if the risk is ignored:

Signal word	Meaning
DANGER!	Refers to imminent danger. Ignoring this sign may lead to death or the most serious injuries.
WARNING	Refers to a potentially hazardous situation. Failure to follow this instruction may lead to death or severe injuries.
CAUTION	Refers to a potentially hazardous situation. Failure to follow this instruction may lead to minor injury or damage to property.
<i>Note</i>	Refers to a danger which, if ignored, may lead to risk to the machine and its function.

Table 1: Explanation of the signal words

1.3 Explanation of the warning signs

Warning signs represent the type and source of a danger:





Warning sign	Type of danger
	General danger zone
	Danger of electric shock
	Danger of explosion
	Danger of damage to machine or functional influences

Table 2: Explanation of the warning signs

1.4 Identification of warnings

Warnings are intended to help you recognise risks and avoid negative consequences.

This is how warnings are identified:

Warning sign	SIGNAL WORD
Description of danger.	
Consequences if ignored.	
⇒ The arrow signals a safety precaution to be taken to eliminate the danger.	

1.5 Instruction for action identification

This is how pre-conditions for action are identified:

- ✓ Pre-condition for action which must be met before taking action.

This is how instructions for action are identified:

➔ Separate step with no follow-up action.

1. First step in a series of steps.
2. Second step in a series of steps.
 - ▶ Result of the above action.

- ✓ **Action completed, aim achieved.**

1.6 References to intellectual property rights

This operating manual must be treated confidentially. Only authorised persons should have access to it. It may only be given to third parties with the written consent of Lutz-Jesco GmbH.

All documents are protected in the sense of the copyright law. It is forbidden to forward on and copy the documents, even in part, as well as to use and communicate their contents, insofar as this is not expressly conceded in writing. Violations are punishable and incur an obligatory payment of damages. Lutz-Jesco GmbH reserves all the rights for the practice of industrial property rights.

1.7 Details for the operator

The operating manual is a significant component of the EASYCHLORGEN electrolysis system. The operator must ensure that the service personnel learn these guidelines.

The operating manual is to be supplemented by the operator regarding the operating instructions; national regulations for Health and Safety at Work and Environmental Protection, including information on the responsibilities of supervision and the observance of operational specifics, e.g. concerning labour organisations, operational sequences and appointed personnel.

Besides the operating manual and the obligatory regulations for Health and Safety at Work applicable in the country of use, as well as in the place of use, the recognised specialist technical regulations for safe and professional work must also be observed.

The operator of the EASYCHLORGEN system may not make any changes, attach fittings or make alterations to the construction of the EASYCHLORGEN system that may impair security, without the written consent of Lutz-Jesco GmbH. This also applies to the installation and setup of safety devices.

Any replacement parts to be used have to correspond to the technical requirements specified by Lutz-Jesco GmbH. This is always guaranteed in the case of original spare parts. Only appoint trained or instructed personnel. Clearly specify the responsibilities of the personnel for operating, servicing and repairing the system.

1.8 Instruction & training course assistance

As a contractor/operator you are obligated to inform and/or instruct the operating personnel about existing provisions of law and accident prevention regulations, as well as existing safety regulations at the plant. In doing so, the different technical qualifications have to be taken into account. The operating personnel must have understood the training and it must be ensured that the training is adhered to.

Only in this way can you ensure that your personnel work in a safety conscious and risk aware manner. This should be controlled on a regular basis. As the contractor/operator you should therefore obtain confirmation of each of the employee's attendance in writing.

On the following pages you will find examples of the training course topics, as well as a main form to copy for the confirmation of attendance.

If the operating personnel still require further training after the system has been delivered to the operator, please contact Lutz-Jesco GmbH.

1.9 Example of training course topics

For safety:

- Accident prevention regulations
- General safety precautions
- Action to be taken in an emergency
- Safety precautions for operating
- Safety devices
- Definition of symbols and signs

To operate

- How to operate the controls
- Elimination of operational disturbances
- Interpretation of fault indications

For maintenance and service instructions:

- Inspection/testing of the system
- Cleaning the system and exchange of replacement parts

2 Safety

2.1 General warnings

The following warnings are intended to help you to eliminate the dangers that can arise while handling the device. Risk prevention measures always apply regardless of any specific action.

Safety instructions warning against risks arising from specific activities or situations can be found in the respective sub-chapters.

	DANGER!
<p>Mortal danger from electric shock!</p> <p>Live parts can inflict fatal injuries.</p> <p>⇒ Ensure that the mains voltage is switched off before opening the control cabinet door.</p>	

	DANGER!
<p>Danger to life through explosions!</p> <p>When using dosing devices without ATEX certification in a potentially explosive area, explosions can occur that result in fatal injuries.</p> <p>⇒ Never use the device in potentially explosive areas.</p>	

	DANGER!
<p>Increased risk of accidents due to insufficient qualification of personnel!</p> <p>The equipment and accessories may only be installed, operated and maintained by personnel with sufficient qualifications. Insufficient qualification will increase the risk of accidents.</p> <p>⇒ Ensure that all action is taken only by personnel with sufficient and corresponding qualifications.</p> <p>⇒ Prevent access to the system for unauthorised persons.</p>	

2.2 Hazards due to non-compliance with the safety instructions

Failure to follow the safety instructions may endanger not only persons, but also the environment and the device.

The specific consequences can be:

- failure of important functions of the device and of the corresponding system,
- failure of required maintenance and repair methods,
- danger to persons,
- danger to the environment caused by substances leaking from the system.

2.3 Working in a safety-conscious manner

Besides the safety instructions specified in this operating manual, further safety rules apply and must be followed:

- accident prevention regulations
- safety and operating provisions
- environmental protection provisions
- applicable standards and legislation

2.4 Personal protective equipment

Based on the degree of risk posed by the dosing medium and the type of work you are carrying out, you must use corresponding protective equipment. Although the dosing media produced by the EASYCHLORGEN system is classified non-hazardous, the following protective equipment is recommended:



Protective clothing



Protective Gloves



Protective Goggles

Corresponding protective equipment must be used during these tasks:

- Commissioning
- Working on pressurised dosing devices
- Shutdown
- Maintenance
- Disposal

2.5 Personnel qualification

Any personnel who work on the device must have appropriate special knowledge and skills.

Anybody who works on the device must meet the conditions below:

- attendance at all the training courses offered by the owner
- personal suitability for the respective activity
- sufficient qualification for the respective activity
- training in how to handle the device
- knowledge of safety equipment and the way this equipment functions
- knowledge of these operating instructions, particularly of safety instructions and sections relevant for the activity
- knowledge of fundamental regulations regarding health and safety and accident prevention.

All persons must generally have the following minimum qualification:

- training as specialists to carry out work on the device unsupervised,
- sufficient training that they can work on the device under the supervision and guidance of a trained specialist.

This operating manual differentiates between these user groups:

2.5.1 Specialist staff

Specialist staff are able, thanks to their professional training, knowledge and experience as well as knowledge of the respective provisions, to do the job allocated to them and recognise and/or eliminate any possible dangers by themselves.

2.5.2 Trained electricians

Due to their professional training, knowledge and experience as well as knowledge of specific standards and provisions, trained electricians are able to do the electrical work assigned to them and to recognise and avoid any potential dangers by themselves.

They are specially trained for their specific working environment and are familiar with relevant standards and provisions.

They must comply with the legally binding regulations on accident prevention.

2.5.3 Trained persons

Trained persons have received training from the operator about the tasks they are to perform and about the dangers stemming from improper behaviour.

Trained persons have attended all trainings offered by the operator.

2.5.4 Personnel tasks

In the table below, you can check what personnel qualifications are the pre-condition for the respective tasks. Only people with appropriate qualifications are allowed to perform these tasks!

Qualification	Activities
Specialist staff	<ul style="list-style-type: none"> ■ Installation ■ Hydraulic installations ■ Commissioning ■ Taking out of operation ■ Fault rectification ■ Maintenance ■ Repairs ■ Disposal
Trained electricians	<ul style="list-style-type: none"> ■ Electrical installation ■ Rectifying electrical faults ■ Electrical repairs
Trained persons	<ul style="list-style-type: none"> ■ Storage ■ Transportation ■ Control

Table 3: Personnel qualification

3 Intended Use

3.1 Notes on product warranty

Any non-designated use of the device can impair its function and the protection provided. This leads to invalidation of any warranty claims!

Please note that liability is on the side of the user in the following cases:

- The device is operated in a manner which is not consistent with these operating instructions, particularly safety instructions, handling instructions and the section "Intended Use".
- Information on usage and environment (see section 5 "Technical data") is not adhered to.
- If people operate the device who are not adequately qualified to carry out their respective activities.
- No original spare parts or accessories of Lutz-Jesco GmbH are used.
- Unauthorised changes are made to the device.
- The user uses different salt quality than that indicated in this instruction manual.
- Maintenance and inspection intervals are not adhered to as required or not adhered to at all.
- The device is commissioned before it or the corresponding system has been correctly and completely installed.
- Safety equipment has been bridged, removed or made inoperative in any other way.

3.2 Intended purpose

The EASYCHLORGEN on-site electrolytic chlorination system is intended for the following purpose: Generation of a <1% sodium hypochlorite solution using salt, water and electrical energy, with the resulting media to be used as a disinfection agent for the chlorination of drinking water, swimming pool and industrial waters.

The concentration of the sodium hypochlorite solution produced is 0.6% (+/-0.1%) Cl₂ by weight.

3.3 Device revision

This operating manual applies to the following devices:

Device	Month / year of manufacture
EASYCHLORGEN	10/2014 onwards

Table 4: Device revision

3.4 Sodium Chloride Chemical Specification

The EASYCHLORGEN system is designed to be used with dry crystalline/ granular salt. Salt can be purchased in bulk/ pallet quantities to obtain best economy. When ordering salt from your supplier always specify the brand or specific quality you require, so that, in the unlikely event of any shortage of stock, you will still receive an equivalent grade of salt. The use of pure vacuum dried (PVD) salt is not recommended without first installing a pea gravel bed (cleaned) into the saturator tank.

Property	Unit	Specification
Arsenic (As)	mg/kg	<13
Cadmium (Cd)	mg/kg	<1.3
Chromium (Cr)	mg/kg	<13
Iron (Fe)	mg/kg	<10
Mercury (Hg)	mg/kg	<0.26
Nickel (Ni)	mg/kg	<13
Manganese (Mn)	mg/kg	<10
Lead (Pb)	mg/kg	<13
Antimony (Sb)	mg/kg	<2.6
Selenium (Se)	mg/kg	<2.6
Bromide	% of NaCl	<0.01
Calcium	% of NaCl	<0.01
Magnesium	% of NaCl	<0.01

Table 5: Sodium chloride chemical specification

	Note
<p>Damage to the system due to incorrect grade of salt.</p> <p>Using the incorrect grade of salt may cause damage to the electrolyser cell and invalidate your warranty!</p> <p>⇒ Please check with your supplier that the salt product supplied meets the minimum specification above.</p>	

3.5 Water Quality

Drinking water or water of a similar quality should be used. It should be free of solids and suspended matter. The temperature of the water entering the system must be in the range of 5-20°C.

3.6 Standard warranty conditions

Equipment	Warranty Period
Electronic devices	2 years
Electrolyser	5 years limited, pro-rata
Wearable items	12 months

Table 6: Standard warranty conditions

4 Product description

4.1 Scope of delivery

Please compare the delivery note with the scope of delivery. The following items are part of the scope of delivery:

- EASYCHLORGEN system
- Operating Instructions
- Optional - dosing pump/s, accessories.

4.2 Design and function

4.2.1 Structure of the device

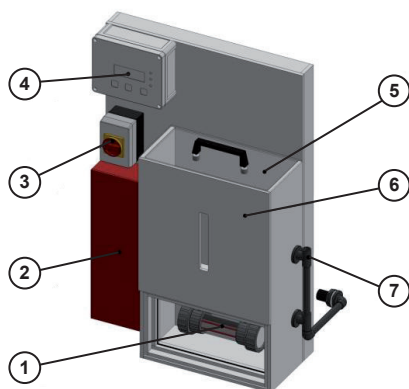

Fig. 1: EASYCHLORGEN COMPACT MODULAR

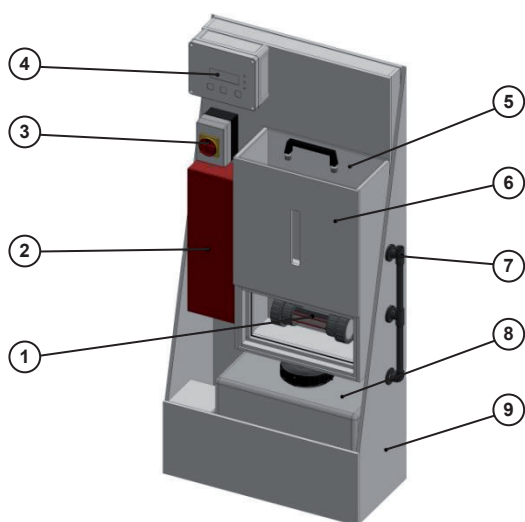

Fig. 2: EASYCHLORGEN COMPACT SKID-1

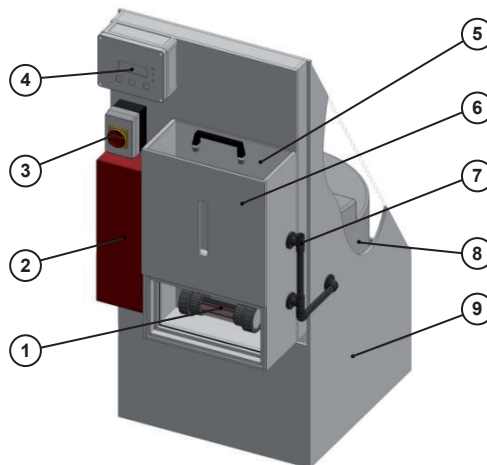

Fig. 3: EASYCHLORGEN COMPACT SKID-2

Position	Description
①	Electrolyser
②	Water flow management control module
③	Electric supply isolator
④	Control panel
⑤	Salt saturator / hopper
⑥	Visual salt level indicator and brine saturation chamber
⑦	Ventilation exhaust
⑧	Product storage tank
⑨	Floor standing skid and integrated spill containment

Table 7: Description of components

4.2.2 Function description

EASYCHLORGEN Compact is a fully automatic system for the preparation of dilute sodium hypochlorite solution containing 0.5-0.7% Cl₂, from the raw materials of salt, softened water and electrical energy.

The operator is required to fill the salt saturator hopper ⑥ with salt. From this, the system automatically produces a concentrated brine solution which is then diluted with water to the correct strength for efficient electrolysis at the water flow control module ②. The diluted brine is then delivered to the electrolytic cell ① where a DC electric current is passed through the solution, producing sodium hypochlorite. The hypochlorite solution produced is delivered to a product storage tank ⑧ ready for dosing via a chemical dosing pump (optional extra).

The batching process is continued automatically until the product storage tank (8) is filled. The filling of the product storage tank and the batching process is managed automatically by the control panel (4). A small quantity of Hydrogen gas is produced as a by-product of electrolysis. This gas is safely vented to an outdoor position via a pipe connected to the Ventilation connection (7).

4.2.2.1 Function sequence in automatic operation

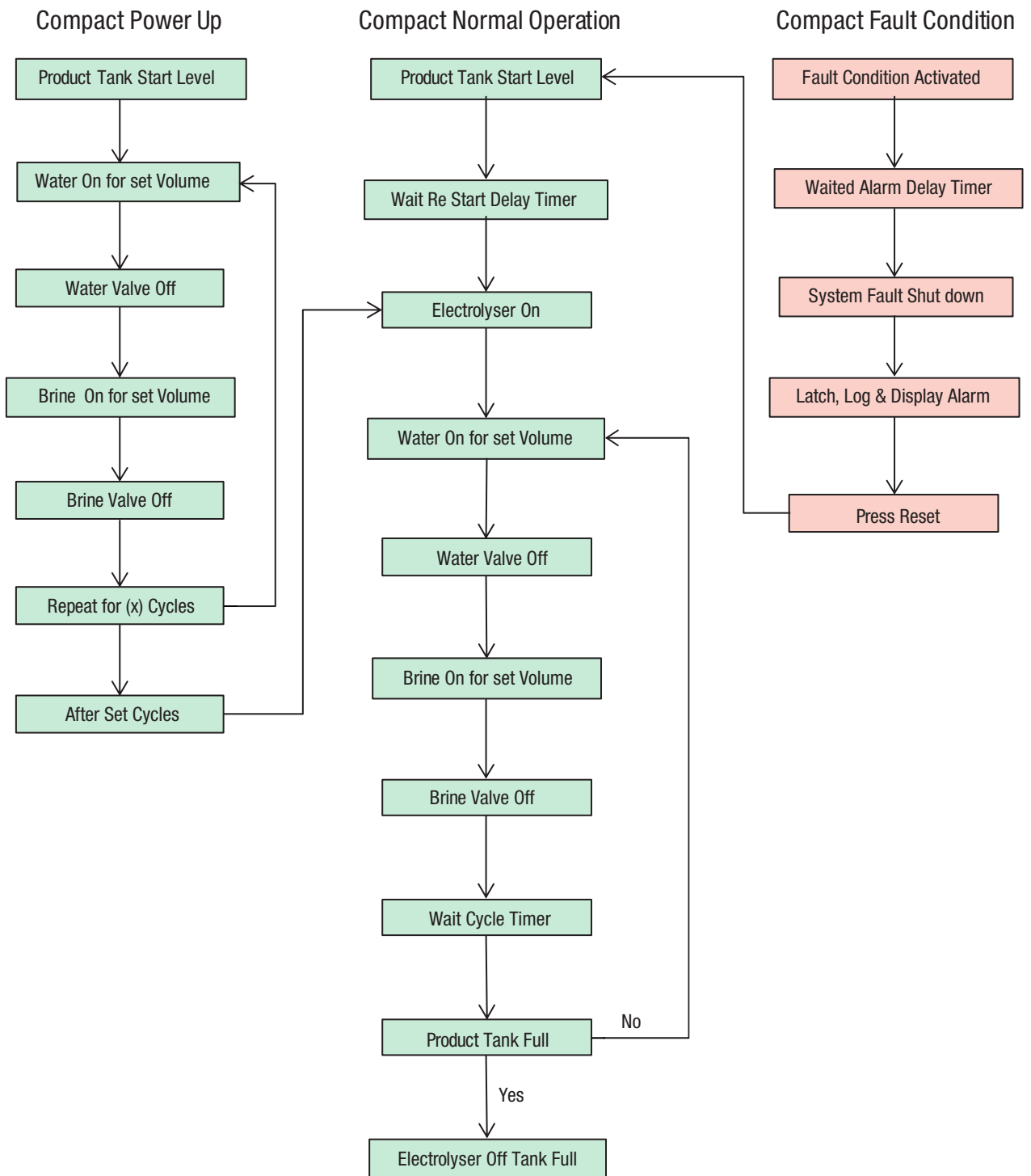

Fig. 4: Function sequence

4.2.3 Rating plate

The rating plate contains information on the safety and functional method of the product. The rating plate must be kept legible for the duration of the service life of the product.

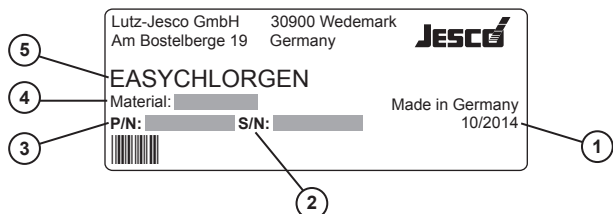

Fig. 5: Rating plate

No.	Description
①	Month/ year of manufacture
②	Serial number
③	Part number
④	Material
⑤	Product name

Table 8: Rating plate

5 Technical data

5.1 Output data

EASYCHLORGEN Compact series				
Model:		25	50	100
Chlorine capacity	g/h	25	50	100
Chlorine concentration	g/l	5 - 7		
Liquid product output	l/h	5	10	20
Liquid product storage*	L	50/200	50/200	50/200
Salt storage capacity	kg	50		

Table 9: Output data

* refers to EASYCHLORGEN skid system with integrated product tank

5.2 Operating conditions and limits

EASYCHLORGEN Compact series				
Model:		25	50	100
Nominal water consumption	l/h	25	50	100
Nominal salt consumption	kg/h	0.08	0.16	0.33
Operating pressure	Bar	1.5 - 10		
Ambient temp	°C	+5 to +40†		
Water supply temp	°C	+8 to +20*		

Table 10: Operating conditions and limits

† request ventilation upgrade kit.

* water chiller required above 20°C

5.3 Electrical specifications

EASYCHLORGEN Compact series				
Model:		25	50	100
Power supply	Ø	1, 230VAC		
Power consumption	kWh	0.25	0.5	0.75
Protection class	IP	54		

Table 11: Electrical specifications

5.4 Connection dimensions

Description	Size
EASYCHLORGEN Water connection	½" BSPm x 8mmOD push-fit tube adaptor
Water softener connections (if supplied)	¾" BSPm
Hydrogen vent line	½" / 20mm uPVC solvent socket
Electrical connection point (skid option)	M20 (20mm x 1,5) female socket
Control panel cable terminations	M20, max.12mmOD 3 core cable, 1.0mm ²
Option – Ventilation kit	2" / 63mm uPVC solvent socket

Table 12: Connection dimensions

5.5 Components coming into contact with the media

Description	Material
Electrolytic cell	PVC, titanium, PTFE, FPM.
Product transfer pipe	PVC
Product tank*	MDPE
Product tank level switch assy	PVDF/PVC, FPM

Table 13: Connection dimensions

*EASYCHLORGEN skid systems with integrated product tank

5.6 Other data

EASYCHLORGEN Compact-Skid-1				EASYCHLORGEN Compact-Skid-2			EASYCHLORGEN Compact - Modular			
Model:		25	50	100	25	50	100	25	50	100
Empty weight	kg	50	50	51	65	65	66	35	35	36

Table 14: Other data

6 Dimensions

All dimensions in mm

6.1 EASYCHLORGEN Compact Modular

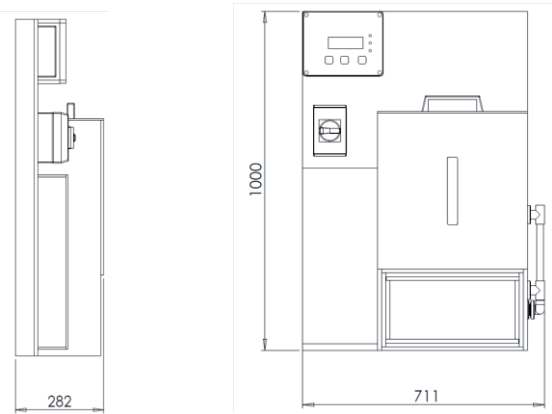

Fig. 6: Dimensions EASYCHLORGEN Compact Modular

6.3 EASYCHLORGEN Compact SKID-2

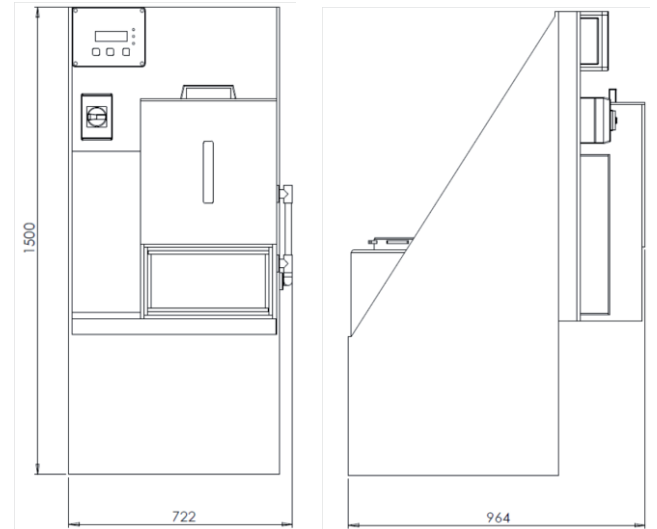

Fig. 8: Dimensions EASYCHLORGEN Compact SKID-2

6.2 EASYCHLORGEN Compact SKID-1

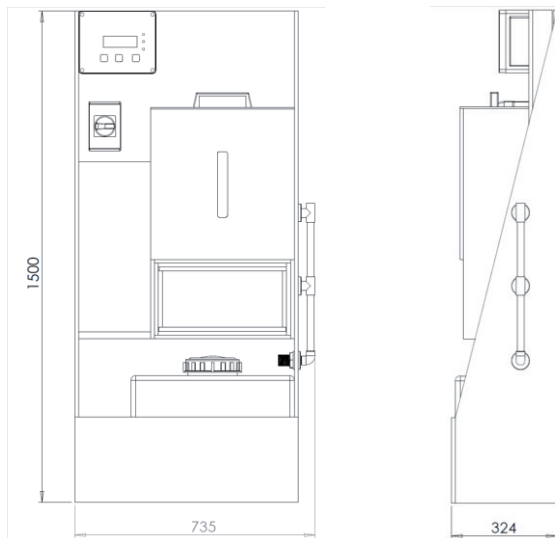





Fig. 7: Dimensions EASYCHLORGEN Compact SKID-1

7 Installation

	WARNING
<p>Increased risk of accidents due to insufficient qualification of personnel!</p> <p>This device and its accessories may only be installed, operated and maintained by personnel with sufficient qualifications. Insufficient qualification will increase the risk of accidents.</p> <p>⇒ Ensure that all action is taken only by personnel with sufficient and corresponding qualifications.</p> <p>⇒ Prevent access to the system for unauthorised persons.</p>	

	WARNING
<p>Danger of personal injury and damage to property!</p> <p>The device is extremely heavy. The failure to take adequate safety precautions during transportation and to act with caution can lead to accidents involving personal injuries and damage to property. Limbs can be crushed when the device is set up.</p> <p>⇒ Transport the device using a floor conveyor that is suitable for the load such as a pallet truck, forklift truck or crane.</p> <p>⇒ Wear safety shoes while transporting the device.</p>	

	Note
<p>Damage to the system due to incorrect installation</p> <p>The failure to observe installation instructions (e.g. use of unsuitable tools, incorrect torque) can damage the system parts.</p> <p>⇒ Use suitable tools.</p> <p>⇒ Take care not to over-tighten fittings.</p>	

7.1 Installation location

7.1.1 EASYCHLORGEN skid system

Precondition for action:

- ✓ A firm and level floor is required for the skid mounted system. Refer to dimensions section 6.
- ✓ The system must be accessible for operation, day-to-day filling with salt and for maintenance.
- ✓ Refer to installation schematic "Skid" on page 21.

Perform the following working steps:

1. Locate the skid unit into its intended permanent position.
2. Install the hydrogen gas detector above the location of the EASYCHLORGEN system, preferably up against the underside of the room ceiling or at the highest point in the immediate room. The sensor head unit is supplied with a fixing bracket that must be used in order to facilitate quick and easy replacement of the sensor head at the time of future maintenance/replacement.
3. Unless a softened water source is available on site, a suitable location for the softener filter device is necessary. See softener options in section 7.2.2 below.

✓ **Location of skid system complete.**

7.1.2 EASYCHLORGEN modular

Precondition for action:

- ✓ A solid wall or suitable rigid frame must be available for the modular EASYCHLORGEN wall mounting unit
- ✓ A firm and level floor is available for the external product tank facility supplied.
- ✓ The system must be accessible for operation, day-to-day filling with salt and for regular/routine maintenance procedures.
- ✓ Refer to installation schematic "Modular" on page 22.

Perform the following working steps:

1. Locate the modular unit into position (wall/frame).
2. Locate the external product tank unit adjacent to the EASYCHLORGEN unit.
3. Install the hydrogen gas detector above the location of the EASYCHLORGEN system, preferably up against the underside of the room ceiling or at the highest point in the immediate room. The sensor head unit is supplied with a fixing bracket that must be used in order to facilitate quick and easy replacement of the sensor head at the time of future maintenance/replacement.
4. Unless a softened water source is available on site, a suitable location for the softener filter device is necessary. See softener options in section 7.2.2 below.

✓ **Location of modular unit complete.**

7.1.3 Air blower ventilation option

An air blower ventilation kit may have been supplied within the scope of the system. This device is intended to assist with the safe extraction of hydrogen from the EASYCHLORGEN unit over vent pipe run greater than 15m in length.

Precondition for action:

- ✓ suitable outside vent termination point provided
- ✓ suitable local wall/frame mounting of the air blower device adjacent to the EASYCHLORGEN unit.
- ✓ refer to air blower schematics on pages 23 and 24.

Perform the following working steps:

1. Mount the air blower enclosure box on to the wall/frame as close to the EASYCHLORGEN unit as possible and a minimum of 200 mm above floor level.
 2. Ensure the enclosure is not obstructed and retains full clearance of its air intake.
 3. The 2"/63 mm manifold should be braced with a pipe bracket where necessary.
- ✓ **Location of air blower unit complete.**

7.2 Hydraulic installation

7.2.1 Water supply

	Note
Damage to the system due to sediment in water.	
Water containing sediment may damage or adversely impact on the performance of the system.	
⇒ Make sure that the water is always free of sediment.	

Precondition for action:

- ✓ A minimum cold water supply pressure of 1.5 Bar is required.
- ✓ The equipment must be supplied with clean softened water of a quality similar to drinking water. Waters which are also high in magnesium content may reduce the life of the water softener resin. (A softener device may have been supplied within the scope of the system and will require installing correctly.)
- ✓ A verifiable double check valve or pipe disconnecter in the drinking water supply is fitted upstream of the entire EASYCHLORGEN system and any ancillary softener equipment if the local conditions require it.
- ✓ A pressure reducing valve should be fitted to the water supply if the supply pressure is greater than 10 bar.

7.2.2 Softened water supply

If softened water is freely available on-site, please proceed to the next section 7.2.3.

If no softened water is freely available on-site, the following information and instructions will need to be followed.

7.2.2.1 Filter cartridge softener option

If a filter softener kit has been supplied within the scope of the system, please adhere to the follow instructions.

Precondition for action:

- ✓ Suitable water supply available.

Perform the following working steps:

1. Install the filter kit immediately upstream of the EASYCHLORGEN unit within the cold water supply pipe work.
 2. Fit inlet and outlet isolation valves pre and post filter in order to provide isolation function during filter maintenance.
- ✓ **Filter softener cartridge device installed.**

7.2.2.2 Auto regenerative softener option

If an automatic regenerative softener unit has been supplied within the scope of the system, please adhere to the follow instructions.

Precondition for action:

- ✓ suitable water supply available

Perform the following working steps:

1. Install the softener unit on a firm level base within easy reach of the EASYCHLORGEN system and near to a local waste water drain point.
2. Follow the general installation instructions. Ensure the softener is fitted with isolation valves on the inlet and outlet connections in order to carry out future maintenance of the unit.
3. A softened water sample tap should be fitted to enable testing of the water supply post-softened water and pre-EASYCHLORGEN.
4. Connect the softener' water outlet to the EASYCHLORGEN using the ½" BSPm x 8mmOD tube adaptor supplied with the system. Use flexible 8mmOD tubing to connect to the 8mmOD inlet fitting of the EASYCHLORGEN unit.

7.2.3 External product tank option

The EASYCHLORGEN Compact Modular is provided with an external product tank 50/100/200 litres capacity. Larger/customised tanks are available to special order.

The interconnecting pipe work must be installed as detailed within the installation diagram provided with the tank facility unit.

7.2.4 Hydrogen ventilation

	DANGER!
<p>Danger to life through explosions!</p> <p>Incorrect installation of the hydrogen vent may cause irreversible damage to the system components and may even create an explosive atmosphere!</p> <p>⇒ Make sure to install the hydrogen vent correctly.</p>	

The EASYCHLORGEN requires the installation of a ventilation pipe duct circuit between the unit and to a suitable exterior outside termination vent point (normally at high level >3m), in order to safely vent any hydrogen gas liberated from the electrolytic process.

Plan the pipe route as direct and straight as possible and always on an incline from the vent discharge connection on the skid to a discharge point within 15 metres.

For pipe runs longer than 15m, an Air Blower Kit should be fitted and a 2"/63mm diameter pipe should be used so that the airflow volume can be maintained >40m³ per hour.

Use wide radius bends instead of elbows to reduce air friction. DO NOT install any unions or any disconnection points at any point along the vent pipe work.

To comply with Health & Safety requirements the vent termination point on the external wall should not be located directly beneath any air intake and must be located at least 0.8m from any window or possible source of ignition. If the external vent pipe work is located in a public area, or there is a possibility of vandalism, it should be protected with a suitable steel cage/pipe capping.

It is advisable to provide the following warning signs in the plant room and exterior vent point:

- Warning Sign
- No Smoking
- No Naked Flames

Contact your authorised installer for further advice.

7.2.4.1 Standard hydrogen ventilation (<15m)

Precondition for action:

- ✓ suitable outside vent point provided

Perform the following working steps:

1. Install a length of 1/2" / 20mm ventilation piping from the socket connection located on the right hand side of the EASYCHLORGEN to the exterior vent point provided.

2. Provide and fix appropriate signage at the vent point in accordance with local rules.

- ✓ **Standard ventilation installation complete.**

7.2.4.2 Air blower ventilation (>15m)

An air blower ventilation kit may have been supplied within the scope of the system. This device is intended to assist with the safe extraction of hydrogen from the EASYCHLORGEN unit over vent pipe run greater than 15m in length.

Precondition for action:

- ✓ air blower kit suitably located
- ✓ suitable outside vent point provided

Perform the following working steps:

1. Install a length of 1/2" / 20mm uPVC piping from the socket connection located on the right hand side of the EASYCHLORGEN Compact to the air blower manifold tee piece.
2. Install a length of 2"/63mm uPVC pipe duct from the air blower manifold to the external/outside vent point.
3. Provide and fix appropriate signage at the vent point in accordance with local rules.

- ✓ **Standard ventilation installation complete.**

7.3 Electrical installation

	DANGER
<p>Mortal danger from electric shock!</p> <p>Live parts can inflict fatal injuries.</p> <p>⇒ Disconnect from the electricity supply before working on any equipment.</p> <p>⇒ Secure all devices to prevent it from being switched on again.</p>	

7.3.1 EASYCHLORGEN skid system

Precondition for action:

- ✓ unit located correctly

Perform the following working steps:

1. Wire in accordance with the wiring diagram on page 21.
 2. Connect the voltage supply to the rotary isolator, via the M20 connection point provided on the left side skid panel.
 3. Earth the device in accordance with local regulations.
 4. Interconnect the M12 cable assembly to the EASYCHLORGEN control panel and the hydrogen gas detector. An M20 connection point on the left side skid panel is provided for this cable route.
 5. Interconnect any auxiliary wiring (for devices supplied outside the scope of the standard system) using the spare cable glands provided.
- ✓ **Skid system wiring complete.**

7.3.2 EASYCHLORGEN modular system

Precondition for action:

- ✓ system components located correctly

Perform the following working steps:

1. Wire in accordance with the wiring diagram on page 21.
 2. Connect the power supply cable to the rotary isolator cable gland provided.
 3. Connect the external product tank level switch wiring cable assembly to the control panel.
 4. Interconnect the M12 cable assembly to the EASYCHLORGEN control panel and the hydrogen gas detector. An M20 connection point on the left side skid panel is provided for this cable route.
 5. Interconnect any auxiliary wiring (for devices supplied outside the scope of the standard system) using the spare cable glands provided.
- ✓ **Modular system wiring complete.**

7.3.3 Auto regenerative softener option

Precondition for action:

- ✓ The water softener requires a separate 110V-240Vac power supply.

Perform the following working steps:

1. Connect the softener transformer module mains input cable to the power supply provided with a suitable switch fused device.
 2. Connect the low voltage jack plug cable assembly into the plug receptacle at the back of the softener control module.
 3. Connect the backwash remote inhibit signal cable from the softener valve head to the EASYCHLORGEN control panel in accordance with the wiring diagram on page 21.
- ✓ **Softener wiring complete.**

7.3.4 Air blower ventilation kit option

Precondition for action:

- ✓ The device and vent pipe correctly located and installed.
- ✓ A suitable switched fused power supply is available within 2m of installed device.

Perform the following working steps:

4. Connect the air blower power lead to the switch fused power supply in accordance to local rules.
 5. Connect the air flow sensor to the EASYCHLORGEN control panel, in accordance with the wiring diagram on page 21. A spare available M20 cable gland entry is provided on the control panel.
- ✓ **Air blower wiring complete.**

7.3.5 Wiring circuit

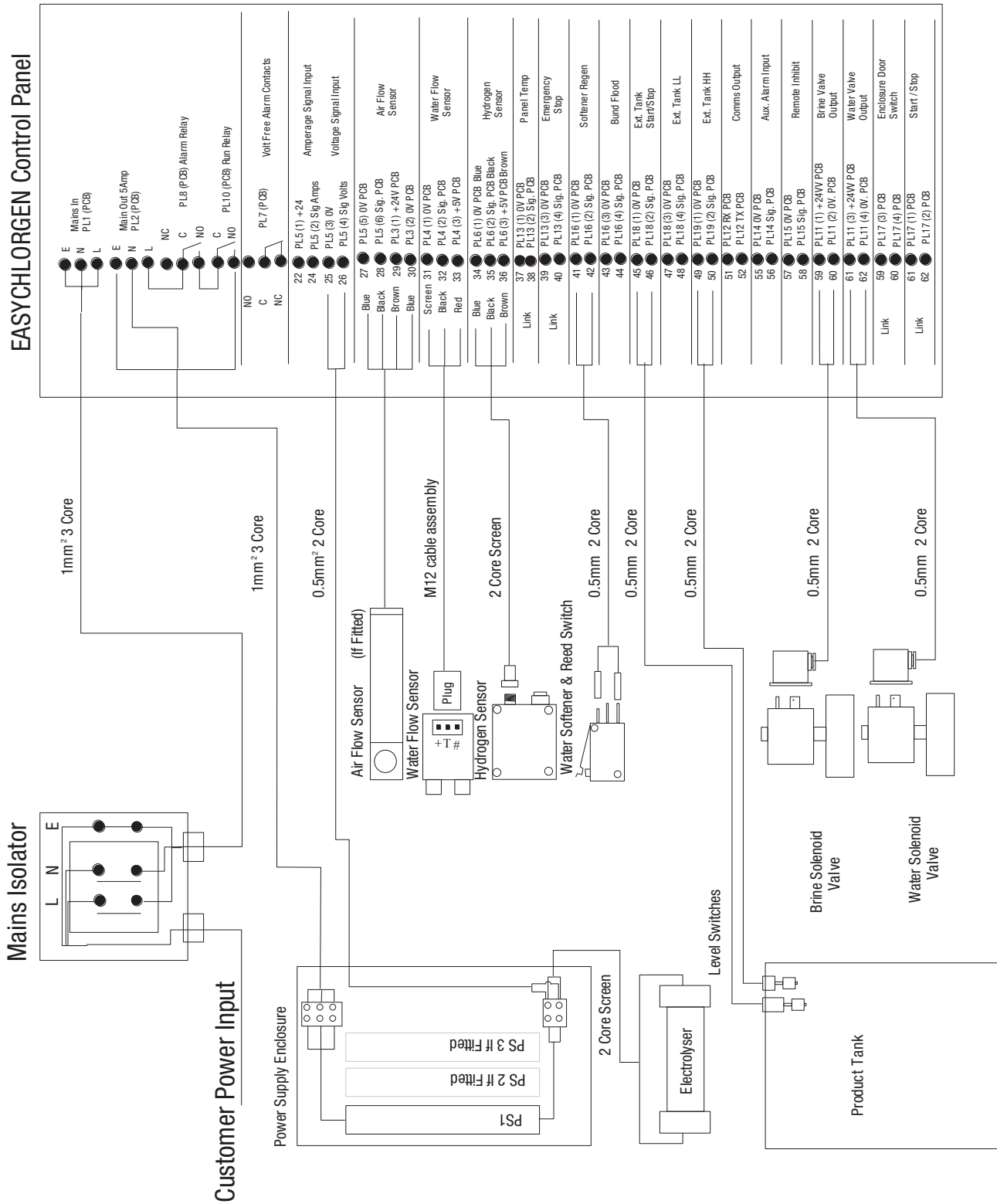

Fig. 9: Wiring circuit

7.4 Installation schematics

7.4.1 SKID - standard atmospheric hydrogen vent

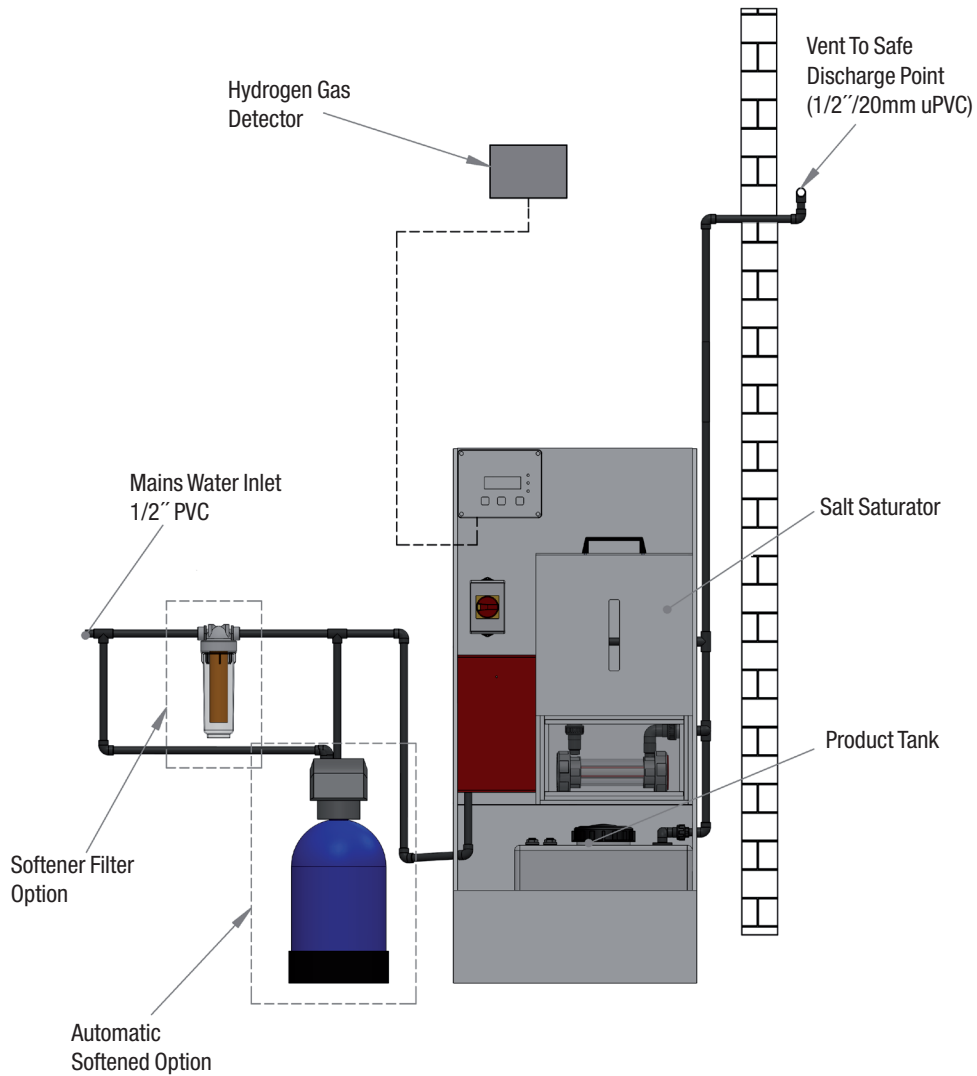

Fig. 10: SKID - standard atmospheric hydrogen vent

7.4.2 MODULAR - standard atmospheric hydrogen vent

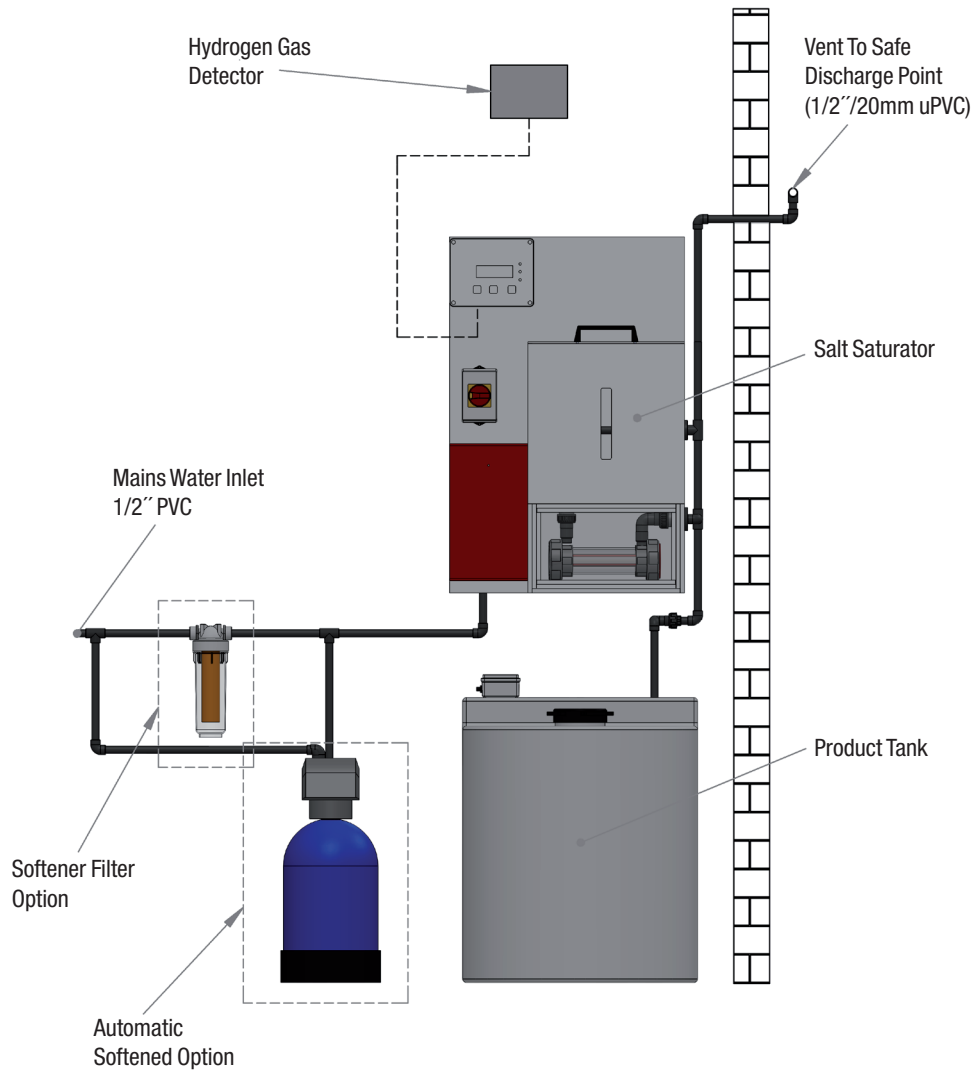

Fig. 11: MODULAR - standard atmospheric hydrogen vent

7.4.3 SKID – air blower hydrogen vent

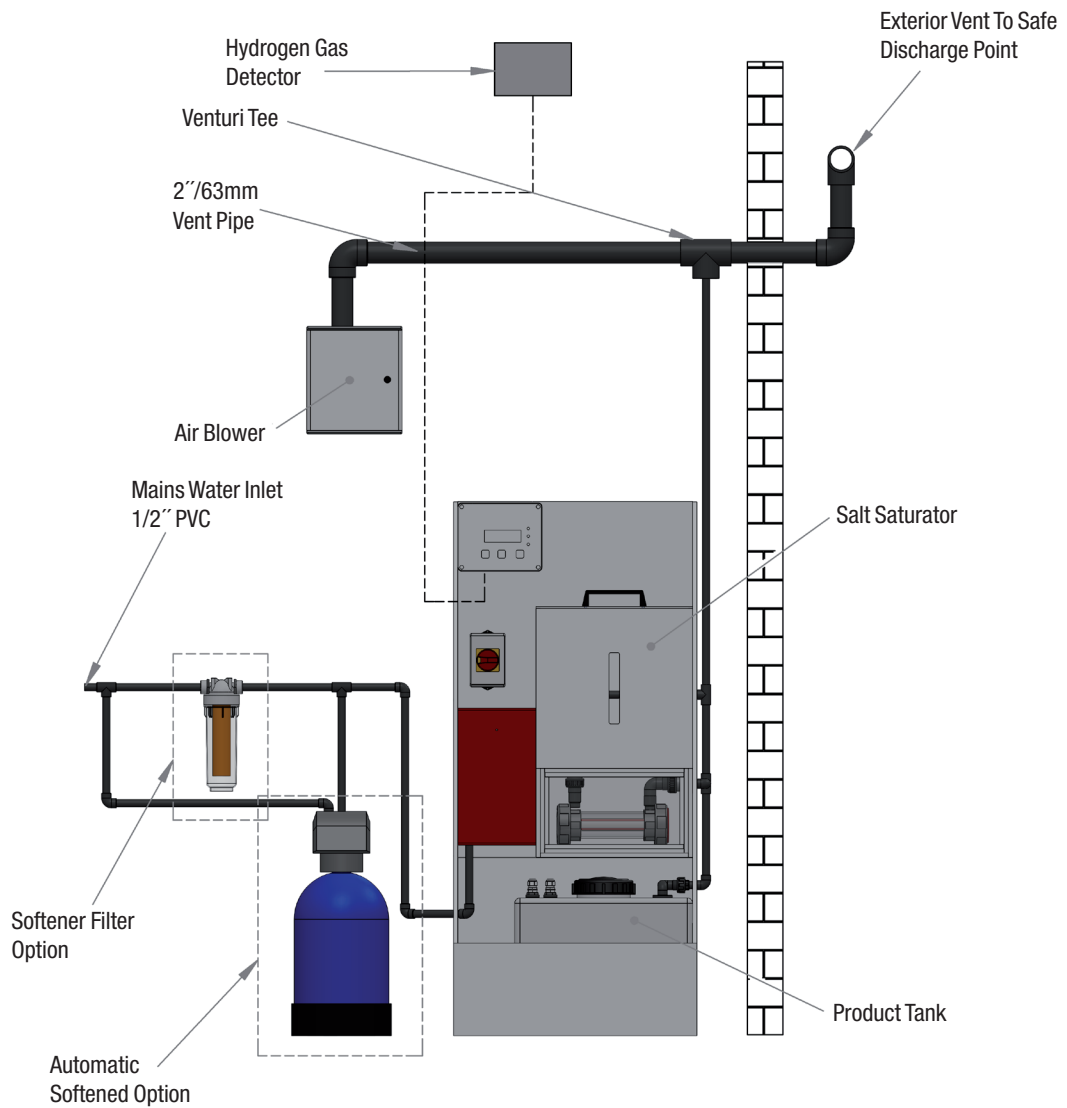

Fig. 12: SKID – air blower hydrogen vent

7.4.4 MODULAR – air blower hydrogen vent

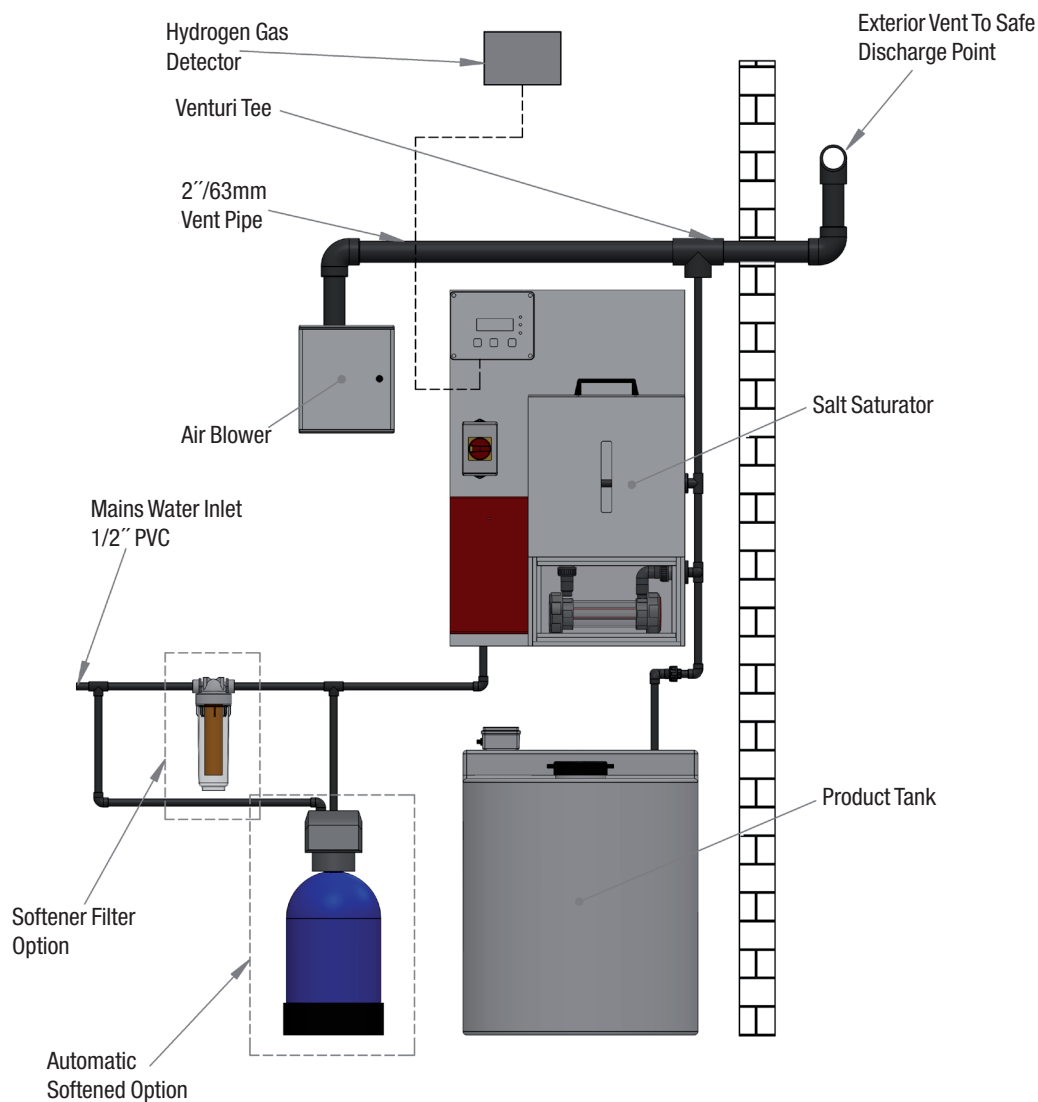

Fig. 13: MODULAR – air blower hydrogen vent

8 Control

8.1 Control display

The operation of the EASYCHLORGEN Compact electrolytic chlorine generation and preparation system is performed via the universal EASYCHLORGEN control panel.



Fig. 14: Control display

The system can be configured and operated via the control interface. An operating field with two direction keys and an enter confirmation key are available for this purpose.

Key	Function
	Scroll UP selection button
	Scroll DOWN selection button
	ENTER selection confirmation button

Table 15: Key functions

The control interface also indicates current operational system status via three bright LEDs:

Green LED	system healthy
Amber LED	maintenance action
Red flashing LED	system fault

	System healthy (GRN)
	System warning /Maintenance action (AMB)
	System fault (flashing RED)

The display screen will always describe the system status or fault condition in conjunction with the appropriate LED symbol representation:

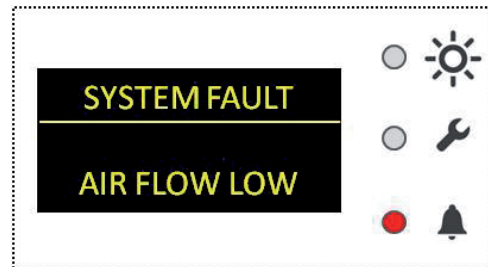

Fig. 15: System fault

System fault is the present condition in this example and the ENTER key has the following assignment:



By pressing the ENTER button the fault will be accepted and the system will reset and attempt to resume normal operation.

9 Start-up

9.1 Turning on the system

Preconditions for actions:

- ✓ The system is configured according to the factory setup.
- ✓ The system has been installed in accordance with section 7, Installation.
- ✓ The control device is earthed.

Perform the following working steps:

1. Set the main rotary isolator switch to ON
 - ▶ Start-up screen appears:



Fig. 16: Start-up screen

- ▶ System will perform a set number of water and brine batch cycles to initially charge the electrolytic cell with a minimum volume of brine solution prior to automatically starting normal generation/batch cycles.

- ✓ **The device is switched on.**

9.2 Commissioning the system

Preconditions for actions:

- ✓ A softened water supply is connected and ready either via a regenerative softener or softener filter cartridge supplied within the scope of the system or via an existing soft water supply already available on site.
- ✓ The softened water supply should be confirmed by performing a water hardness YES/NO test. The sample will be a GREEN result for soft water and RED result for hard water. The result MUST BE GREEN, i.e. soft water. DO NOT PROCEED further until a reliable softened water supply is available.
- ✓ The salt saturator is filled with a pre-charge of the correct specification of granular salt.
- ✓ Two litres of cold (preferably softened) water has been manually added to the salt saturator 30 minutes prior to initial start-up to ensure an adequate volume of saturated brine solution is available (only necessary for initial start-up event).
- ✓ The hydrogen gas sensor detection kit is correctly installed and electrically connected via the 4-pin plug/M12 cable assembly as per installation instruction.

Perform the following working steps:

1. If an auto regenerative softener is fitted to the system, the hardness setting of the softener should be set to 50mg/l CaCO₃ above the hardness value of the source water.
2. Start-up the EASYCHLORGEN.
3. Check clock settings by pressing and holding the scroll UP key (whilst in System Healthy display screen) for 5 seconds. The following MANUAL INHIBIT screen will appear and stop the system:

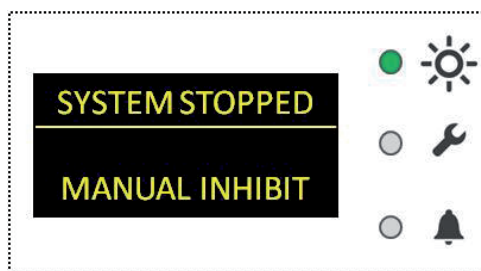

Fig. 17: Manual inhibit

4. Press the ENTER button for 5 seconds to access the Service Menu. The following screen will appear:



Fig. 18: Pin

5. Using the UP/DOWN scroll keys enter the service code 2236 – each digit needs to be individually selected and entered
6. Scroll UP until Program 6 is revealed:

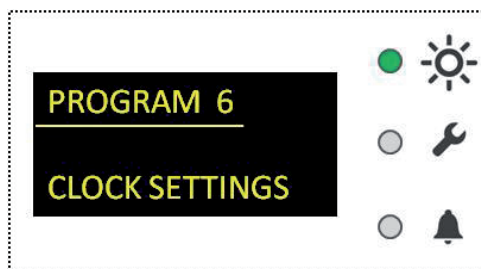

Fig. 19: Program 6

7. Press ENTER and then scroll DOWN to adjust date and time accordingly. Pressing ENTER at the EXIT screen will revert to Service Menu.
8. Scroll UP until Program 1 / End Program Mode is reached. At this point press ENTER and the display will return to the MANUAL INHIBIT screen.
9. To restart the system press and hold the scroll UP key for 5 seconds.
10. System will now resume its previous automatic status.

11. When the SYSTEM HEALTHY screen is visible, scroll DOWN to observe engineer display 1:

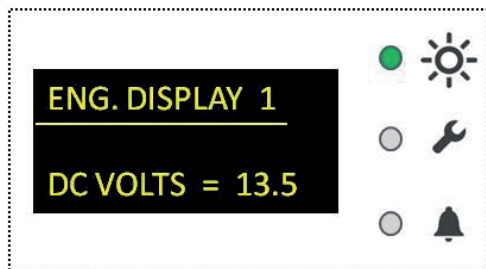

Fig. 20: Engineer display

12. The normal DC Volt reading should be in the range of between 12 and 15 volts.
- ▶ The DC volt reading may take several hours to stabilize on initial commissioning owing to the water/brine solution strength stabilizing.
13. Continue to scroll DOWN to observe Eng. Display 4 which provides a visual indication of the hydrogen threshold as a percentage. An acceptable level of <50% should always be the case. The hydrogen gas detect system is factory set and requires only an annual service inspection/test.
14. After 12 to 24 hours operation it is recommended to perform a chlorine product strength test. The result should ideally be 0.6% +/- 0.1%.
- ✓ **System commissioning completed.**

10 Operation

⚙️
Note

Damage to the system due to incorrect salt!

Failure to observe the correct specification of salt used by this system will most likely result in failure of the system and affect the warranty conditions.

⇒ Use the correct salt.

⚙️
Note

Damage to the system due to hard water supply!

Failure to provide a softened feed water supply for the normal operation of the system will most likely result in failure of the system and affect the warranty conditions.

⇒ Use a softened water supply.

10.1 Automatic Operation

The on-site electrolytic chlorine generation and preparation EASYCHLORGEN system is automated. The softened water supply is automatically regulated according to the system demand. The salt saturator should be refilled with salt manually before allowing it to become empty. Try not to allow level to drop <25% full.

The system process will START and STOP according to the level of the product storage tank facility.

When the tank is full the display will show:



Fig. 21: Tank full

When the system is generating and the tank is filling the display will show:

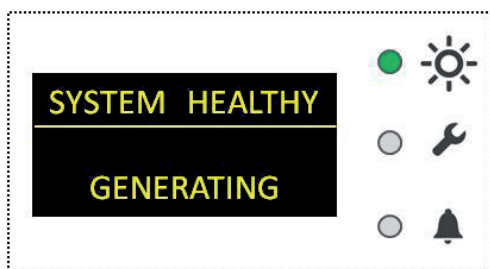

Fig. 22: Generating

10.2 Manual Inhibit

The automatic process may be interrupted by placing the control cycle in to MANUAL INHIBIT mode. This will STOP the automatic electrolytic process.

Whilst the system is displaying SYSTEM STOPPED or SYSTEM HEALTHY, the scroll UP key may be pressed for 5 seconds to place the system into MANUAL INHIBIT mode which halts the system:



Fig. 23: Manual inhibit

Press the scroll UP key again for 5 seconds to resume automatic operation.

10.3 Remote Inhibit

The EASYCHLORGEN may be connected to an external switch intended to stop the system remotely. If the system is stopped remotely the screen will display REMOTE INHIBIT. The system will not resume automatic operation until the remote inhibit function is released.

10.4 Softener Regeneration

If an automatic regenerative softener has been fitted as part of the scope of the system, the softener will automatically regenerate and whilst doing so place the system into STOP mode:



Fig. 24: Softener regeneration

The system will resume automatic operation once the regenerative process, approximately 60 minutes, is complete.

Note

Damage to the system!

Damage to the system due to not refilling regenerative softener with salt!

- ⇒ Regularly check the salt level in the regenerative softener salt saturator and always try to keep it fully topped up with the correct grade softener salt.
- ⇒ The same salt for the EASYCHLORGEN is recommended to be used for this softener device.

8. Reset the cartridge filter volume counter on the EASYCHLORGEN control panel by repeatedly depressing the scroll DOWN key until the Eng.Display 7 is displayed:-

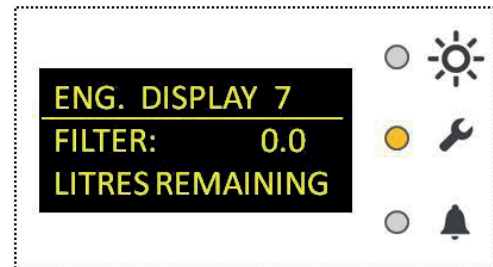

Fig. 26: Engineering display 7

9. Press the ENTER key for 5 seconds and the “litres remaining” value will reset to the correct value.
 10. Press the scroll DOWN key twice to return to the normal operating display.
- ✓ **The cartridge filter is now successfully replaced.**

10.5 Replace Water Softener Cartridge

If a softener cartridge filter has been fitted to the system, the softener cartridge will eventually become exhausted and require replacement.

The EASYCHLORGEN monitors the volume of water consumed in the generating process and will indicate on the display screen when the cartridge requires replacement. In addition, the amber warning lamp will illuminate while the cartridge is becoming exhausted in order to alert the operator that attention is required:

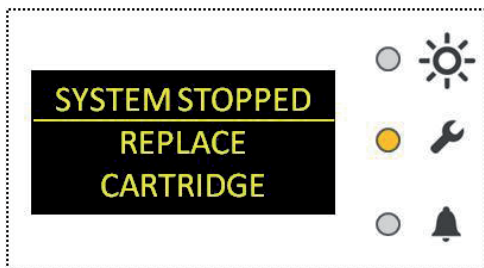

Fig. 25: Replace cartridge

Failure to replace the cartridge when indicated may quickly lead to reduced system performance and unnecessary failure of the system.

Preconditions for actions:

- ✓ Place the system into MANUAL INHIBIT mode.
- ✓ The system water supply at the inlet and outlet of the filter cartridge has been isolated.

Perform the following working steps:

1. Relieve water pressure within the filter bowl by depressing the pressure release button on top of the filter housing or by briefly opening the filter outlet valve and then the softened water sample tap.
2. Remove the filter cartridge bowl using the filter spanner (supplied with the filter kit) taking care not to drop the filter bowl.
3. Dispose of the water contained in the filter bowl to a waste drain.
4. Dispose of the exhausted softener cartridge as commercial waste.
5. Fit the correct new replacement softener cartridge.
6. Open the filter inlet/outlet isolating valves.
7. Take the system out of MANUAL INHIBIT to resume automatic operation.

10.6 Emergency Shutdown

In the event of an emergency, you must immediately disconnect the device from the mains supply. This can be achieved by switching the rotary isolator to the off position.

If an auxiliary Emergency Stop device has been connected to the device then this can be activated to stop the system. If this is the case, the EASYCHLORGEN system will need to be reset on the panel by pressing the ENTER button once the Emergency Stop device has been released.

10.7 Record Log of Operation

In order to maintain and monitor the performance of the system and ensure the system is operated within manufacturer warranty conditions, the operator has the responsibility to complete an operator log.

Actions to perform:

- ➔ Record parameters as required on the log sheet each time salt is added.
 - ➔ Record parameters as required on the log sheet at regular intervals, approximately weekly.
- ✓ **Warranty compliance.**

11 Shutdown

11.1 Short-term shutdown (up to 6 months)

Perform the following working steps:

1. Isolate the power supply to the EASYCHLORGEN via the rotary isolator switch.
2. Switch the mains on again to create a Start-up cycle. When the start-up cycle finishes immediately switch off again. Repeat this regime twice in total. The purpose of this regime is to rinse the electrolytic circuit of residual brine and sodium hypochlorite solution.
3. Isolate the feed water supply.
4. Switch off the auto regenerative softener if fitted to the system.

✓ **System shut down for the short term.**

11.2 Long-term shutdown

Perform the following working steps:

5. Isolate the power supply to the EASYCHLORGEN via the rotary isolator switch.
6. Empty the contents of the salt saturator. Any salt residue can be removed using a wet and dry vacuum cleaner.
7. Pour 4 litres of cold water into the salt saturator to purge the electrolytic cell system of residual sodium hypochlorite product solution. The solution will safely rinse into the tank system.
8. Place a sign on the system indicating that the unit will require commissioning prior to the next Start-up.

11.3 Storage

Required actions:

- ✓ The system has been shut down in accordance with the section 11.2 "Long-term shutdown".

Storing the system correctly will extend its service life. You should avoid negative influences such as extreme temperatures, high humidity, dust, chemicals, etc.

Ensure ideal storage conditions where possible:

- The storage place must be cold, dry, dust-free and generously ventilated,
- Temperatures between +0°C and +50°C,
- Relative air humidity must not exceed 90%.

11.4 Transportation

Required actions:

- ✓ The system has been shut down in accordance with the section 11.2 "Long-term shutdown".
- The system may only be transported when empty of all salt and water/solution throughout the system.
 - Use suitable lifting and transport equipment where necessary.

- The danger of cold embrittlement of the plastics which it contains means that the system may not be transported at temperatures under 0°C. Cracks in welded seams, container walls and piping could result.

If the system is sent back to the supplier/manufacturer, please follow sections 16 "Declaration of no objection" on page 39 and "Warranty application" on page 41.

11.5 Disposal of old equipment

- The system must be disposed of responsibly and in accordance with applicable local laws and regulations. It should not be disposed of as domestic waste.
- As the disposal regulations differ from country to country, please consult your supplier if necessary.
- In Germany, the manufacturer must provide free-of-charge disposal, provided the system has been safely returned along with a declaration of no objection (see page 39).

12 Maintenance

Products by Lutz-Jesco are manufactured to the highest quality standards and have along service life. However, some parts are subject to operational wear. This means that regular visual inspections are necessary to ensure a long service life. Regular maintenance will protect the system from operational interruptions.

	DANGER
<p>Mortal danger from electric shock!</p> <p>Live parts can inflict fatal injuries.</p> <p>⇒ Before carrying out any maintenance, always disconnect the system from the power supply.</p> <p>⇒ Secure the system to prevent it from being switched on by accident.</p>	

	WARNING
<p>Increased risk of accidents due to insufficient qualification of personnel!</p> <p>The system and its accessories may only be installed, operated and maintained by personnel with sufficient qualifications. Insufficient qualification will increase the risk of accidents.</p> <p>⇒ Ensure that all action is taken only by personnel with sufficient and corresponding qualifications.</p> <p>⇒ Prevent access to the system for unauthorised persons.</p>	

12.1 Maintenance Intervals

The system requires regular maintenance to prevent errors, poor performance and even failure. This table gives an overview of maintenance work and the intervals at which you must carry it out. The next few sections contain instructions for carrying out this work.

Interval	Level	Maintenance
On demand	Operator	<ul style="list-style-type: none"> ■ Replace softener cartridge if fitted
Annual	Technician	<ul style="list-style-type: none"> ■ Clean water flow restrictor ■ Check water & brine solenoid valve integrity ■ Check/Test hydrogen gas sensor
2 yrs (or >10,000 operating hours)	Technician	<ul style="list-style-type: none"> ■ Replace pipe gaskets ■ Check/Test/Replace hydrogen gas sensor
5 yrs	Technician	<ul style="list-style-type: none"> ■ Major overhaul

Table 16: Maintenance intervals

12.1.1 Clean water flow restrictor

The flow restrictor may occasionally be compromised due to sediment fouling carried in via the water supply. One of the reasons the EASYCHLORGEN may alarm on "NO WATER FLOW" could be a result of a blockage at the point of the restrictor.

Preconditions for actions:

- ✓ Isolate the power supply to the EASYCHLORGEN via the rotary isolator switch.
- ✓ Isolate the feed water supply to the EASYCHLORGEN.

Perform the following working steps:

1. Remove the EASYCHLORGEN front outer red plastic protective mechanical cover by removing the black protective nut cap. Unscrew the single retaining nut and remove the red cover.
 2. Push back the tube fitting collar with finger and thumb and pull out the red restrictor from the assembly. Check the internal orifice is clean and free of debris.
 3. Replace the restrictor in reverse operation to above ensuring that the restrictor fully engages into the tube fittings to make a water tight seal.
 4. Refit the red mechanical cover.
 5. Start-up the system as per section 9.1.
- ✓ **The restrictor has been successfully checked.**

12.1.2 Check water & brine solenoid valve integrity

One or both solenoids may eventually wear and allow a small discharge flow of water when normally closed. One of the reasons the EASYCHLORGEN may alarm in "VOLTAGE HIGH" is due to the solenoids inadvertently passing water and producing a low salinity solution entering the electrolytic cell.

Precondition for actions:

- ✓ Isolate the power supply to the EASYCHLORGEN via the rotary isolator switch.

Perform the following working steps:

1. Remove the EASYCHLORGEN front outer red plastic protective mechanical cover by removing the two black protective nut caps. Unscrew the two nuts and remove the red cover.
2. Detach the flexible tubing from out of the top exit point of the water solenoid valve, see water control diagram on page 31. Remember to push the tube fitting collar down with finger and thumb to enable the release of the tubing.
3. There should be no water passing/leaking through the solenoid valve. If there is any slight leakage then the solenoid should be dismantled and cleaned or replaced.
4. After checking/replacing the water solenoid valve, reinsert the tubing into the tube fitting. Ensure the tube fully engages into the tube fitting to make a water tight seal.

6. Repeat the above steps 1 to 4 for the brine solenoid valve.
7. Start-up the system as per section 9.1.

✓ **The solenoid valves have been successfully checked/replaced.**

12.1.3 Hydrogen gas detector inspection

The hydrogen gas (H₂) detection system is very important to ensure a safe environment. The H₂ detector should be routinely tested annually in order to verify a safe system of work. The H₂ level detected in the immediate atmosphere is displayed on the screen and should normally be below 50%. This reading can be displayed by scrolling DOWN at the EASY-CHLORGEN panel to reveal Eng.Display 4:

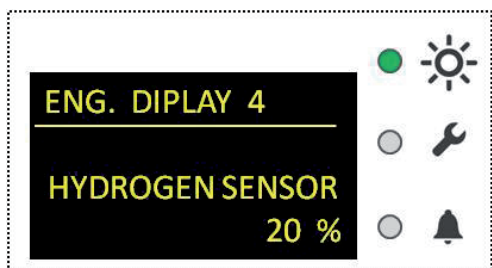

Fig. 27: Engineering display 4

Precondition for actions:

✓ EASYCHLORGEN system in normal automatic operation.

Perform the following working steps:

1. Prepare the EASYCHLORGEN H₂ test device (available separately) as per device instructions.
2. Position the tester device so that it liberates its test gas directly at the sensor head as per the device instructions.
3. The reading on the display will quickly rise to 100% at which point will trigger the hydrogen sensor fault:

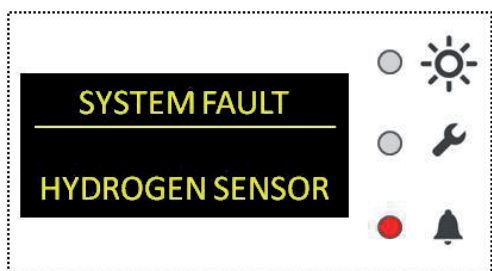

Fig. 28: Hydrogen sensor fault

4. Remove the H₂ test device from the sensor and the reading will quickly return to a low reading below 50%. If the sensor does not react or read 100% during the test then the sensor must be replaced.
 - ▶ When the display reads 100%, this is equivalent to a H₂ detection level in the atmosphere of less than 25% of the LEL threshold.

✓ **The hydrogen gas detection system has been successfully checked/sensor replaced.**

12.1.4 Replace gaskets

Elastomers exposed to the electrolytic process are subject to wear and require routine replacement every two years regardless of operating hours.

Prior to commencing this maintenance action, the electrolytic hydraulic circuit requires purging.

Precondition for actions:

✓ Perform Short-term shut down procedure, see section 11.1.

Perform the following working steps:

1. Remove the electrolyser cell enclosure window by removing the vertical window bead retainers and then the horizontal window bead retainers.
2. Carefully loosen the cell inlet and outlet union collars until the cell can be carefully rested on to the base of the electrolyser chamber with the inlet and outlet connections facing upward to prevent further spillage.

	WARNING
Increased risk of accidents due to brine spillage!	
<p>A residual of brine solution may drip from the saturator chamber above.</p> <p>⇒ Wipe away any spillage immediately.</p>	

3. Replace the flat gaskets with the correct spare parts.
4. Refit the cell to the union assemblies taking care not to over-tighten the union collars.
5. If the EASYCHLORGEN is a manufactured skid system model, the o-ring at the product tank inlet
6. union connection will require replacement with the correct o-ring part.
7. Ensure all pipe connections are correctly aligned and hand-tight prior to start-up.
8. Ensure the electrolyser chamber window is refitted correctly back into position.
9. Ensure the water supply is turned on to the system
10. Perform start-up as per section 9.1.

✓ **Gasket replacement successfully carried out.**

12.1.5 Major service

	Note
Damage to the system due to incorrect maintenance!	
The system and its accessories may only be installed, operated and maintained by personnel with sufficient qualifications.	
⇒ Make sure the maintenance is performed correctly by qualified personnel.	

A major overhaul of the EASYCHLORGEN system is required every 5 years, regardless of operating hours. An approved EASYCHLORGEN service technician will be required to conduct this maintenance regime.

Control devices, the electrolytic cell, the salt saturator and all associated pipe work will require thorough inspection and cleaning and worn/defective parts replaced as necessary.

The water and brine solenoid valves will require replacement.

The electrolytic cell will require an acid clean and its two cell casing end cap gaskets replacing and the two terminal o-rings replacing.

All standard pipe connection elastomers will require replacement.

The hydrogen gas detect sensor head will require replacement.

If an auto regenerative softener is fitted, the softener will require a full service of its valve head assembly and the internal softener resin replacing.

All safety switches and safety devices to be fully tested.

Actions to be taken:

- ➔ Contact your EASYCHLORGEN service provider to arrange a major overhaul service.
- ✓ General overhaul will provide for future safe operation and continued routine service.

12.2 Electrolyser cleaning

The electrolyser (electrolytic cell) may require acid cleaning periodically to remove the presence of water hardness scaling and also any heavy metal deposition e.g. iron and manganese deposits.

	One of the reasons the EASYCHLORGEN may alarm in "VOLTAGE HIGH" is due to the electrolyser becoming scaled or fouled with heavy metals.
---	---

Precondition for actions:

- ✓ Perform Short-term shut down procedure, see section 11.1.

Perform the following working steps:

1. Remove the electrolyser cell enclosure window by removing the vertical window bead retainers and then the horizontal window bead retainers.

2. Carefully loosen the cell inlet and outlet union collars until the cell can be carefully rested on to the base of the electrolyser chamber with the inlet and outlet connections facing upward to prevent further spillage.

	WARNING
Increased risk of accidents due to brine spillage!	
A residual of brine solution may drip from the saturator chamber above.	
⇒ Wipe away any spillage immediately.	

3. Connect the acid wash cleaning system to the electrolyser in accordance with the operating instructions provided with the EASYCHLORGEN acid washing kit.
4. Completely rinse out and drain the electrolyser with water prior to refitting into the electrolyser chamber.
5. Refit the electrolyser cell to the union assemblies taking care not to over-tighten the union collars.
6. Ensure the electrolyser chamber window is refitted correctly back into position.
7. Ensure the water supply is turned on to the system
8. Perform start-up as per section 9.1.

✓ **Electrolyser acid wash carried out successfully.**

12.3 Finishing maintenance

Perform the following working steps:

1. Make a note of the date and scope of the maintenance performed.
2. Complete any operational, service or commissioning log sheets associated with the EASYCHLORGEN system and as per any associated documents which are contained within this manual.
3. Attach a sticker displaying the maintenance date to the system.
4. To assure correct start up procedures, refer to section 9 "Start-up".

✓ **Maintenance completed.**

Water control circuit schematic

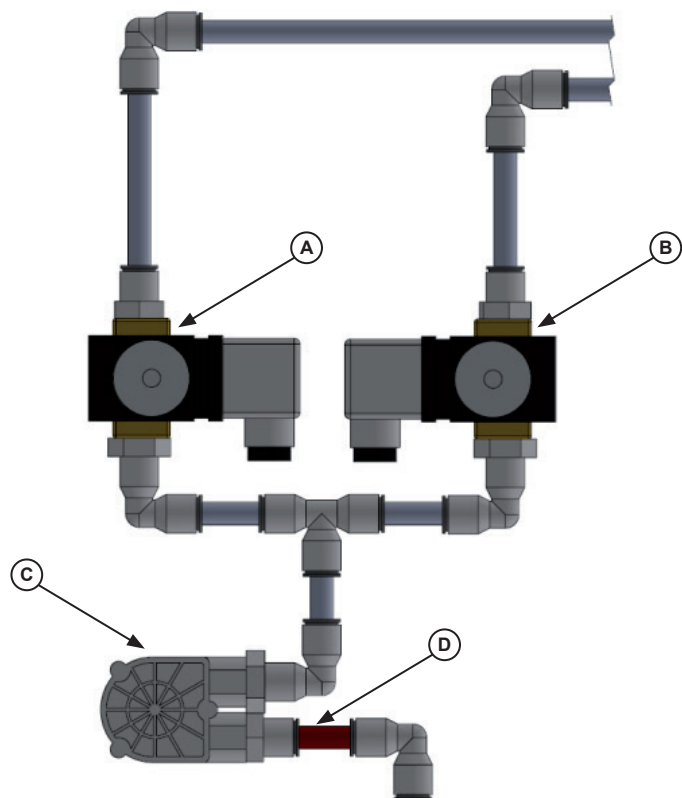

Fig. 29: Water control circuit schematic

Key ID	Component Description
A	Water solenoid valve
B	Brine solenoid valve
C	Water flow sensor
D	Water flow restrictor

Table 17: Component Description

13 Troubleshooting

See below for information about how to rectify faults on the control device or the system in general. If you cannot eliminate the fault, please consult with your approved EASYCHLORGEN service provider on further measures or return the device/system component for repair.

Display	Fault	Possible causes	Remedy
System Fault / Emergency Stop	The emergency stop bulb has been depressed	Manually activated Accidentally activated Wire breakage / Loose connection	Reset emergency stop switch and then reset Reset emergency stop switch and then reset Check wiring and ensure switch is NC when healthy
System Fault / Panel Temperature	The temperature of 50°C has been exceeded within the control panel	Blocked inlet/outlet filters Panel cooling fan Fault Panel Temperature switch fault Wire Breakage/Loose connection	Clean or replace filters then Reset Check and replace then reset Check and replace then reset Check wiring and ensure switch is NC when Healthy
System Fault / Ext Tank High	The High Level point within the external product tank has been exceeded	Failure of the Start/Stop Switch Solenoid valve passing Back filling through dosing system Wire Breakage/Loose connection	Check and replace then reset Check for swarf or worn valve seat or diaphragm Check dosing system non return valves clean Check wiring and ensure switch is NC when Healthy
System Fault / Ext Tank Low	The Low Level point within the external product tank has been reached	Failure of the Start/Stop Switch System in Manual Inhibit System in Remote Inhibit System in Fault Condition Take of demand too high Failure of the low Level switch	Check and replace then reset Remove system from Manual Inhibit Remove system from Remote Inhibit Check system fault and reset Reduce product dose rate Check wiring and ensure switch is NC when Healthy
System Fault / Auxiliary Alarm	An Auxiliary Alarm input has been activated	Auxiliary Alarm has been Activated Wire Breakage/Loose connection	Check and Reset Check wiring and ensure switch is NC when Healthy
System Fault / Enclosure Door	Electrolyser & De-Gasing Chamber door/window open	Door has been manually removed Faulty Door switch Wire Breakage/Loose connection	Replace door and reset Check and replace Check wiring and ensure switch is NC when Healthy
System Fault / Hydrogen Sensor	Hydrogen Level has exceeded 100% of the alarm value (<25% LEL)	Broken or damaged pipe work Ventilation Blockage Sensor not connected Wire Breakage/Loose connection	Check and replace Check and clean Connect sensor Wire Breakage/Loose connection
System Fault / Voltage High	Electrolyser High Volt Set Point has been exceeded	Lack of Salinity within the Electrolyser Scale on Electrodes Alarm point set too low. Wire Breakage/Loose connection	Check for blockage then check S.G. Check Softener operating correctly, Check salt Quality then Check and Adjust Replace wire/Tighten connection/Clean Connection
System Fault / Voltage Low	Electrolyser Low Volt Set point has been reached	High Salinity within Electrolyser Power Supply Failure Faulty Run Relay	Check Salt setting adjust and reset Check and replace Check and Replace
System Fault / No Water Flow	Insufficient Water Flow within the batch process cycle time period	Low Water Pressure Blockage within water pipe work Blockage within Softener Faulty Flow Meter Wire Breakage/Loose connection	Check service provider Check and Clean Check, Service or replace Check and replace Wire Breakage/Loose connection
System Fault / Low Air Flow	Low Air flow from Blower	Blockage in ventilation pipe work Air Blower Failure Air Flow Sensor Failure Wire Breakage/Loose connection	Check and remove blockage Check and Replace Check Clean or Replace Wire Breakage/Loose connection

Table 18: Troubleshooting

14 Spare Parts

14.1 Recommended spare parts

14.1.1 EASYCHLORGEN Compact 25 model

Part	Content
Filter cartridge type-S* (Cx-x-F2-x-Tx-Vx)	Standard capacity softener filter cartridge
Filter cartridge type-H* (Cx-x-F3-x-Tx-Vx)	High capacity softener filter cartridge

Table 19: Spare parts - EASYCHLORGEN Compact 25 model

(* depending on type supplied with scope of system – check build code on manufacturer machine plate)

14.1.2 EASYCHLORGEN Compact 25/50/100 models

Part	Content
Water flow restrictor	8mm OD red restrictor
Tank level switch (universal)	PVDF/FPM level switch assembly with 1.5m cable
Hydrogen gas sensor**	Hydrogen gas detector head unit & spare bracket

Table 20: Spare parts - EASYCHLORGEN Compact 25/50/100

 **EASYCHLORGEN system will not operate with a defective hydrogen sensor

14.2 Maintenance sets

Part	Content
Electrolyser (Compact 25 to 50)	Two cell casing gaskets (63mm OD), two union flat gaskets, two terminal o'rings.
Electrolyser (Compact 100)	Two cell casing gaskets (75mm OD), two union flat gaskets, two terminal o'rings.
Hydraulic pipe circuit (Compact 25 to 100)	Two union flat gaskets (cell), one union o-ring (product tank)

Table 21: Maintenance sets

15 EC conformity/declaration of incorporation



(DE) EG-Konformitätserklärung

Hiermit erklären wir, dass das nachfolgend bezeichnete Gerät aufgrund seiner Konzipierung und Bauart sowie in der von uns in Verkehr gebrachten Ausführung den einschlägigen grundlegenden Sicherheits- und Gesundheitsanforderungen der aufgeführten EG-Richtlinien entspricht. Bei einer nicht mit uns abgestimmten Änderung am Gerät verliert diese Erklärung ihre Gültigkeit.

(EN) EC Declaration of Conformity

We hereby certify that the device described in the following complies with the relevant fundamental safety and sanitary requirements and the listed EC regulations due to the concept and design of the version sold by us.

If the device is modified without our consent, this declaration loses its validity.

(FR) Déclaration de conformité CE

Nous déclarons sous notre propre responsabilité que le produit ci-dessous mentionné répond aux exigences essentielles de sécurité et de santé des directives CE énumérées aussi bien sur le plan de sa conception et de son type de construction que du modèle que nous avons mis en circulation.

Cette déclaration perdra sa validité en cas d'une modification effectuée sur le produit sans notre accord explicite.

(ES) Declaración de conformidad CE

Por la presente declaramos que, dados la concepción y los aspectos constructivos del modelo puesto por nosotros en circulación, el aparato mencionado a continuación cumple con los requisitos sanitarios y de seguridad vigentes de las directivas de la U.E. citadas a continuación.

Esta declaración será invalidada por cambios en el aparato realizados sin nuestro consentimiento.

Bezeichnung des Gerätes:

Elektrolysechlorungsanlage zur Verwendung vor Ort

Description of the unit:

On-site electrolytic chlorination system

Désignation du matériel:

Descripción de la mercancía:

Typ:

EASYCHLORGEN Compact 25 / 50 / 100

Type:

EASYCHLORGEN 180 / 280 / 560 / 1100 / 2200 / 4250 / 8500

EG-Richtlinien:

Maschinenrichtlinie / Machinery (98/37/EC)

EC directives:

Niederspannungsrichtlinie (Richtlinie betreffend elektrische Betriebsmittel zur Verwendung innerhalb bestimmter Spannungsgrenzen) (2006/95/EG)
Verwendete Normen: EN 60335-1:2002 und EN 60335-2-51:2003

Electrical equipment designed for use within certain voltage limits (2006/95/EC).
Standards used: EN 60335-1: 2002 and EN 60335-2-51: 2003.

Elektromagnetische Verträglichkeit / Electromagnetic compatibility (2004/108/EG)

Dokumentationsbevollmächtigter: Authorized person for documentation:

Lutz-Jesco GmbH

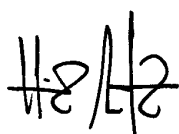

Heinz Lutz
Geschäftsführer / Chief Executive Officer
Lutz-Jesco GmbH
Wedemark, 01.10.2014

Lutz-Jesco GmbH
Am Bostelberge 19
30900 Wedemark
Germany

16 Declaration of no objection

Please copy the declaration, stick it to the outside of the packaging and return it with the device.

Declaration of no objection

Please fill out a separate form for each appliance!

We forward the following device for repairs:

Device and device type: Part-no.:

Order No.: Date of delivery:

Reason for repair:

.....

.....

Dosing medium

Description: Irritating: Yes No

Properties: Corrosive: Yes No

We hereby certify, that the product has been cleaned thoroughly inside and outside before returning, that it is free from hazardous material (i.e. chemical, biological, toxic, flammable, and radioactive material) and that the lubricant has been drained.

If the manufacturer finds it necessary to carry out further cleaning work, we accept the charge will be made to us.

We assure that the aforementioned information is correct and complete and that the unit is dispatched according to the legal requirements.

Company / address: Phone:

..... Fax:

..... Email:

Customer No.: Contact person:

Date, Signature:

17 Warranty Application

Warranty Application

Please copy and send it back with the unit!

If the device breaks down within the period of warranty, please return it in a cleaned condition with the complete warranty application, filled out.

Sender

Company: Phone: Date:

Address:

Contact person:

Manufacturer order no.: Date of delivery:

Device type: Serial number:

Nominal capacity / nominal pressure:

Description of fault:.....

.....

.....

.....

.....

.....

.....

.....

.....

.....

.....

Service conditions of the device

Point of use / system designation:.....

.....

.....

Accessories used (suction line etc.):.....

.....

.....

.....

.....

Commissioning (date):

Duty period (approx. operating hours):

Please describe the specific installation and enclose a simple drawing or picture of the chemical feed system, showing materials of construction, diameters, lengths and heights of suction and discharge lines.

Index

A		R	
Assembly	17	Rating plate	12
C		S	
Chemical Specification	8	Safety	6
Connections		Scope of delivery	10
2-channel digital display	21	Shutdown	30
Control	25	Signal words	4
D		Specialist staff	7
Declaration of no objection	39	Start-up	26
Device revision	8	Structure of the device	10
Dimensioned drawings	15	T	
Dimensions	15	Technical data	13
E		Trained electricians	7
Electrical installation	19	Trained persons	7
F		Troubleshooting	35
Foreseeable misuse	9	W	
Function description	10	Warnings	
G		General warnings	6
General warnings	6	Marking	4
H		Warning sign	4
Handling instructions	5	Warranty claim	41
Hazards due to non-compliance with the safety instructions	6	Warranty conditions	9
I		Working in a safety-conscious manner	6
Installation	16		
Intended purpose	8		
Intended use	8		
M			
Maintenance	31		
N			
Notes for the Reader	4		
O			
Operation	28		
Operator controls of the digital display	25		
P			
Personal protective equipment	7		
Personnel qualification	7		
Personnel tasks	7		
Product description	10		
Product warranty	8		

Produktprogramm

Lutz Pumpen GmbH
Postfach 1462 • D-97864 Wertheim
www.lutz-pumpen.de

Produktprogramm

Lutz-Jesco GmbH
Postfach 100164 • D-30891 Wedemark
www.lutz-jesco.de



Fass- und Containerpumpen



Dosierpumpen



Mess- und Regeltechnik



Durchflusszähler



Chlorgasdosierer



Desinfektion



Doppelmembranpumpen



Chemie-Kreiselpumpen



Standard Plus



Zentrifugalpumpen



TECHNOPOOL®

Produkte zur Desinfektion von Schwimmbadwasser auf Basis der Salzwasser-Elektrolyse, Hauswassertechnik



Die Lutz-Jesco App für iPads erhalten Sie im iTunes App Store. Alle weiteren Informationen hierzu finden Sie auf www.lutz-jesco.com



Stammhaus
Lutz-Jesco GmbH
Am Bostelberge 19
30900 Wedemark
Germany

Tel.: +49 5130 5802-0
Fax: +49 5130 580268

E-Mail: info@lutz-jesco.com
Internet: www.lutz-jesco.de

Ungarn
Lutz-Jesco Üzletég
Vasvári P. u. 9.
9024 Győr
Hungary

Tel.: +36 96 523046
Fax: +36 96 523047

E-Mail: info@lutz-jesco.hu
Internet: www.lutz-jesco.hu

Österreich
Lutz-Jesco GmbH
Aredstraße 7/2
2544 Leobersdorf
Austria

Tel.: +43 2256 62180
Fax: +43 2256 6218062

E-Mail: info@lutz-jesco.at
Internet: www.lutz-jesco.at

Niederlande
Lutz-Jesco Nederland B.V.
Nijverheidstraat 14 C
2984 AH Ridderkerk
Netherlands

Tel.: +31 180 499460
Fax: +31 180 497516

E-Mail: info@lutz-jesco.nl
Internet: www.lutz-jesco.nl



Großbritannien
Lutz-Jesco (GB) Ltd.
Gateway Estate
West Midlands Freeport
Birmingham B26 3QD
Great Britain

Tel.: +44 121 782 2662
Fax: +44 121 782 2680

E-Mail: info@lutz-jesco.co.uk
Internet: www.lutz-jesco.co.uk

USA
Lutz-JESCO America Corp.
55 Bermar Park
Rochester, N.Y. 14624
USA

Tel.: +1 585 426-0990
Fax: +1 585 426-4025

E-Mail: mail@jescoamerica.com
Internet: www.lutzjescoamerica.com

East Asia
Lutz-Jesco East Asia Sdn Bhd
6 Jalan Saudagar U1/16
Hicom Glenmarie Industrial Park
40150 Shah Alam/ Selangor
Malaysia

Tel.: +603 55692322
Fax: +603 55691322

E-Mail: info@lutz-jescoasia.com
Internet: www.lutz-jescoasia.com

Middle East
Lutz-Jesco Middle East FZE
P.O. Box 9614
SAIF-Free Zone Center
Sharjah
UAE

Tel.: +971 6 5572205
Fax: +971 6 5572230

E-Mail: info@jescome.com
Internet: www.jescome.com

