

## Back-pressure and pressure relief valves

### Operating instructions

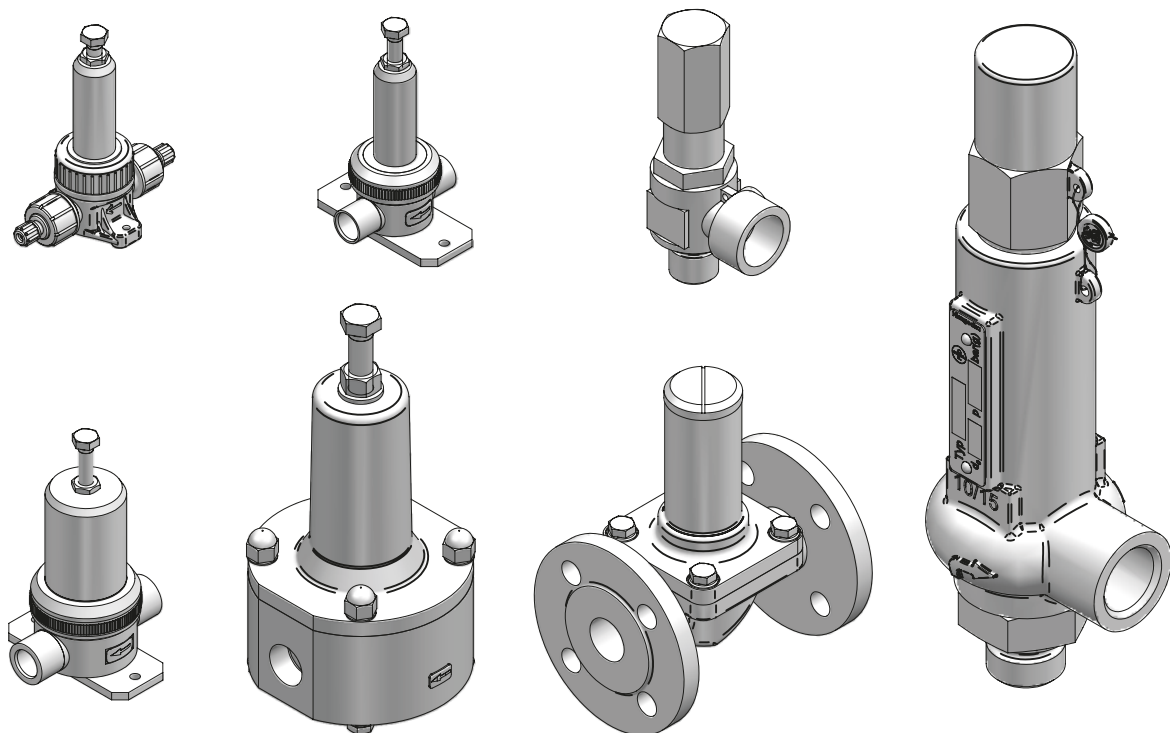

Read the operating manual!

The user is responsible for installation and operation related mistakes!



## Table of Contents

<b>1</b>	<b>Notes for the Reader</b>	4
1.1	General non-discrimination	4
1.2	Explanation of the signal words	4
1.3	Explanation of the warning signs	4
1.4	Identification of warnings	4
1.5	Instruction for action identification	4
<b>2</b>	<b>Safety</b>	5
2.1	General warnings	5
2.2	Hazards due to non-compliance with the safety instructions	6
2.3	Working in a safety-conscious manner	6
2.4	Personal protective equipment	6
2.5	Personnel qualification	6
<b>3</b>	<b>Intended use</b>	8
3.1	Notes on product warranty	8
3.2	Intended purpose	8
3.3	Explosive risk zone	8
3.4	Principles	8
<b>4</b>	<b>Product description</b>	9
<b>5</b>	<b>Technical data</b>	10
<b>6</b>	<b>Dimensions</b>	11
6.1	Valves DN6 - DN15 (spring-loaded diaphragm valve)	11
6.2	Valves DN25 - DN65 (spring-loaded diaphragm valve)	12
6.3	Pressure-relief valve DN6 (spring-loaded seat valve)	13
6.4	Pressure-relief valves DN 10 (spring-loaded seat valve)	13
6.5	Mounting block DN6	14
6.6	Mounting block DN10 – DN15	15
<b>7</b>	<b>Installation</b>	16
<b>8</b>	<b>Operation</b>	17
<b>9</b>	<b>Maintenance</b>	18
9.1	Valves DN6 - DN15 (spring-loaded diaphragm valve)	18
9.2	Valves DN25 - DN65 (spring-loaded diaphragm valve)	19
<b>10</b>	<b>Spare parts</b>	20
10.1	Diaphragms	20
10.2	Seals	20
10.3	Seats for pressure-relief valve DN6	20
<b>11</b>	<b>Declaration of Incorporation</b>	21
<b>12</b>	<b>Declaration of no objection</b>	22
<b>13</b>	<b>Warranty claim</b>	23

# 1 Notes for the Reader

This operating manual contains information and behaviour rules for the safe and designated operation of the product.

Observe the following principles:

- Read the entire operating manual prior to starting-up the device.
- ensure that everyone who works with or on the product has read the operating manual and follows the instructions.
- maintain the operating manual throughout the service life of the product.
- pass the operating manual on to any subsequent owner of the product.

## 1.1 General non-discrimination

In this operating manual, only the male gender is used where grammar allows gender allocation. The purpose of this is to make the text easy to read. Men and women are always referred to equally. We would like to ask female readers for understanding of this text simplification.

## 1.2 Explanation of the signal words

Different signal words in combination with warning signs are used in this operating manual. Signal words illustrate the gravity of possible injuries if the risk is ignored:

Signal word	Meaning
DANGER	Refers to imminent danger. Ignoring this sign may lead to death or the most serious injuries.
WARNING	Refers to a potentially hazardous situation. Failure to follow this instruction may lead to death or severe injuries.
CAUTION	Refers to a potentially hazardous situation. Failure to follow this instruction may lead to minor injury or damage to property.
NOTE	Refers to a danger which, if ignored, may lead to risk to the machine and its function.

Table 1: Explanation of the signal words

## 1.3 Explanation of the warning signs

Warning signs represent the type and source of a danger:





Warning sign	Type of danger
	Danger point
	Danger from potentially-explosive substances
	Danger from corrosive substances
	Danger of damage to machine or functional influences

Table 2: Explanation of the warning signs

## 1.4 Identification of warnings

Warnings are intended to help you recognise risks and avoid negative consequences.

This is how warnings are identified:

Warning sign	SIGNAL WORD
	<b>Description of danger.</b> Consequences if ignored. ⇒ The arrow signals a safety precaution to be taken to eliminate the danger.

## 1.5 Instruction for action identification

This is how pre-conditions for action are identified:

- ✓ Pre-condition for action which must be met before taking action.
- ✘ A resource such as a tool or auxiliary materials required to perform the operating instructions.

This is how instructions for action are identified:

- ➔ Separate step with no follow-up action.
- 1. First step in a series of steps.
- 2. Second step in a series of steps.
  - ▶ Result of the above action.
- ✓ **Action completed, aim achieved.**

## 2 Safety

### 2.1 General warnings

The following warnings are intended to help you to eliminate the dangers that can arise while handling the product. Risk prevention measures always apply regardless of any specific action.

Safety instructions warning against risks arising from specific activities or situations can be found in the respective sub-chapters.

	<b>DANGER</b>
<p><b>Danger to life through explosions!</b></p> <p>The use of devices and fittings without ATEX certification in a potentially explosive atmosphere can result in potentially-fatal explosions.</p> <ul style="list-style-type: none"> <li>⇒ Never use devices and fittings without ATEX certification in a potentially-explosive atmosphere.</li> </ul>	

	<b>WARNING</b>
<p><b>Caustic burns or other burns through dosing media!</b></p> <p>While working on the dosing head, valves and connections, you may come into contact with dosing media.</p> <ul style="list-style-type: none"> <li>⇒ Use sufficient personal protective equipment.</li> <li>⇒ Rinse the dosing pump with a liquid (e.g. water) which does not pose any risk. Ensure that the liquid is compatible with the dosing medium.</li> <li>⇒ Release pressure in hydraulic parts.</li> <li>⇒ Never look into open ends of plugged pipelines and valves.</li> </ul>	

	<b>WARNING</b>
<p><b>Danger from unsuitable materials</b></p> <p>The materials of the product and hydraulic parts of the system must be suitable for the dosing medium used. Should this not be the case, the dosing media may leak.</p> <ul style="list-style-type: none"> <li>⇒ Make sure that the materials you are using are suitable for the dosing medium.</li> <li>⇒ Make sure that the lubricants, adhesives, sealants, etc. that you use are suitable for the dosing medium.</li> </ul>	

	<b>WARNING</b>
<p><b>Danger from too high a pressure!</b></p> <p>All devices and hydraulic fittings on the dosing system must be operated below the maximum permissible pressure. Overly-high pressure peaks can result in the bursting of system parts, the release of dosing medium and injury.</p> <ul style="list-style-type: none"> <li>⇒ Set the pre-tension pressure of the back-pressure and pressure-relief valves so that the pressure during maximum through-flow is does not exceed that permitted for the dosing pump or other devices.</li> <li>⇒ Do not insert the back-pressure and pressure-relief valves with non-adjustable pre-tension pressure in the dosing system under any operating conditions other than those specified in the order. Check the information on the type plate for this purpose.</li> <li>⇒ After installation, adjust the back-pressure and pressure-relief valves with adjustable pre-tension pressure to the operating conditions of the system.</li> </ul>	

	<b>CAUTION</b>
<p><b>Danger when changing the dosing medium!</b></p> <p>Changing the dosing media can provoke unexpected reactions, damage to property and injury.</p> <ul style="list-style-type: none"> <li>⇒ Clean the product and the system parts in contact with the media thoroughly before changing the dosing medium.</li> </ul>	

	<b>CAUTION</b>
<p><b>Increased risk of accidents due to insufficient qualification of personnel!</b></p> <p>Dosing pumps and their accessories may only be installed, operated and maintained by personnel with sufficient qualifications. Insufficient qualification will increase the risk of accidents.</p> <ul style="list-style-type: none"> <li>⇒ Ensure that all action is taken only by personnel with sufficient and corresponding qualifications.</li> <li>⇒ Prevent access to the system for unauthorised persons.</li> </ul>	

	<b>NOTE</b>
<b>Damage from incorrect use as a back-pressure valve</b>	
Damage from incorrect use as a back-pressure valve	
Stainless steel (1.4571) spring-loaded seat valves may not be used as a back-pressure valve. Its use as a back-pressure valve increases wear and shortens the lifetime of the valve.	
⇒ Use the stainless steel (1.4571) spring-loaded seat valve as a pressure-relief valve only.	

### 2.2 Hazards due to non-compliance with the safety instructions

Failure to follow the safety instructions may endanger not only persons, but also the environment and the device.

The specific consequences can be:

- Failure of major functions of the product.
- failure of required maintenance and repair methods,
- danger for individuals through dangerous dosing media,
- danger to the environment caused by substances leaking from the system.

### 2.3 Working in a safety-conscious manner

Besides the safety instructions specified in this operating manual, further safety rules apply and must be followed:

- accident prevention regulations
- safety and operating provisions,
- safety provisions for handling dangerous substances (mostly the safety data sheets to dosing media),
- environmental protection provisions,
- applicable standards and legislation.

### 2.4 Personal protective equipment

Based on the degree of risk posed by the dosing medium and the type of work you are carrying out, you must use corresponding protective equipment. Read the Accident Prevention Regulations and the Safety Data Sheets to the dosing media find out what protective equipment you need.

You will require the minimum of the following personal protective equipment:



Personal protective equipment required	
	Protective goggles
	Protective clothing
	Protective gloves

Table 3: Personal protective equipment required

Wear the following personal protective equipment when performing the following tasks:

- Commissioning,
- Working on the product during operation,
- Shut-down,
- Maintenance work,
- Disposal.

### 2.5 Personnel qualification

Any personnel who work on the product must have appropriate special knowledge and skills.

Anybody who works on the product must meet the conditions below:

- attendance at all the training courses offered by the owner,
- personal suitability for the respective activity,
- sufficient qualification for the respective activity,
- training into the handling of the device,
- knowledge of safety equipment and the way this equipment functions,
- knowledge of this operating manual, particularly of safety instructions and sections relevant for the activity,
- knowledge of fundamental regulations regarding health and safety and accident prevention.

All persons must generally have the following minimum qualification:

- training as specialists to carry out work on the product unsupervised,
- sufficient training that they can work on the product under the supervision and guidance of a trained specialist.

These operating instructions differentiate between these user groups:

### 2.5.1 Specialist staff

Thanks to their professional training, knowledge, experience and knowledge of the relevant specifications, specialist staff are able to perform the job allocated to them and recognise and/or eliminate any possible dangers by themselves.

### 2.5.2 Trained persons

Trained persons have received training from the operator about the tasks they are to perform and about the dangers stemming from improper behaviour.

In the table below you can check what qualifications are the pre-condition for the respective tasks. Only people with appropriate qualifications are allowed to perform these tasks!

Qualification	Activities
Specialist staff	<ul style="list-style-type: none"> <li>■ Assembly</li> <li>■ Hydraulic installations</li> <li>■ Electrical installation</li> <li>■ Maintenance</li> <li>■ Repairs</li> <li>■ Commissioning</li> <li>■ Taking out of operation</li> <li>■ Disposal</li> <li>■ Fault rectification</li> </ul>
Trained persons	<ul style="list-style-type: none"> <li>■ Storage</li> <li>■ Transportation</li> <li>■ Control</li> <li>■ Fault rectification</li> </ul>

Table 4: Personnel qualification

## 3 Intended use

### 3.1 Notes on product warranty

Any non-designated use of the product can compromise its function or intended protection. This leads to invalidation of any warranty claims!

Please note that liability is on the side of the user in the following cases:

- the device is operated in a manner which is not consistent with this operating manual, particularly safety instructions, handling instructions and the section "Intended Use".
- If people operate the product who are not adequately qualified to carry out their respective activities,
- No original spare parts or accessories are used,
- Unauthorised changes are made to the device by the user,
- The user uses different dosing media than those indicated in the order,
- The user does not use dosing media under the conditions agreed with the manufacturer such as modified concentration, density, temperature, contamination, etc.

### 3.2 Intended purpose

Back-pressure and pressure-relief valves are fittings for dosing systems. Depending on the task involved, they are used to increase the dosing accuracy or to protect the system against excess pressure.

#### 3.2.1 Use as a back-pressure valve

With the dosing of fluids, back-pressure valves generate a defined back pressure on the pressure side of a dosing pump.

This is required in the following cases:

- Strongly fluctuating pressure. Exact dosing results are impossible without a back-pressure valve.
- The pressure on the suction side is higher than on the pressure side.
- Dosing in a pressureless line is required.

#### 3.2.2 Use as a pressure-relief valve

Pressure relief valves have an important safety function for protecting the dosing pump and the associated pipes and fittings. The dosing pump can generate a pressure that is many times the rated one.

Various reasons, e.g. soiling or operating errors can result in blocked pressure lines. At an appropriate pressure, a pressure relief valve opens a bypass line and protects the system in this way from damage caused by over-pressure.

### 3.3 Explosive risk zone

The type DN6, 200 bar and DN10, 250 bar spring-loaded seat valves can be deployed in potentially-explosive atmospheres. They may only be used as pressure-relief valves.

All other back-pressure and pressure-relief valves may not be used in a potentially explosive atmosphere.

### 3.4 Principles

- Back-pressure and pressure-relief valves may not be used as non-return valves.
- Back-pressure and pressure-relief valves may not be used as shutoff valves.
- Comply with the information regarding the operating and environmental conditions (see 5 "Technical data" on page 10).
- Any restrictions regarding the viscosity, temperature and density of dosing media must be followed. You must only use dosing media at temperatures above freezing point or below the boiling point of the respective medium.
- The specified flow capacity (see 5 "Technical data" on page 10) applies to uniform flows of water and other liquids, which are comparable to water in terms of viscosity and density, given dosing with a sufficiently-apportioned pulsation damper. An uneven flow without a pulsation damper can result in a far lower flow capacity.
- The materials of the product and hydraulic parts of the system must be suitable for the dosing medium used. In this connection, note that the resistance of these components can change in dependence on the temperature of the media and the operating pressure.



Information on the suitability of materials combined with different dosing media can be found in the Compatibility Chart of the manufacturer.

The information in this resistance list is based on information from the material manufacturers and on expertise obtained from handling the materials.

As the durability of the materials depends on many factors, this list only constitutes initial guidance on selecting material. In all cases, test the equipment with the chemicals you use under operating conditions.

## 4 Product description

### Rating plate

There is information on the equipment about safety or the product's way of functioning. The information must stay legible for the duration of the service life of the product.

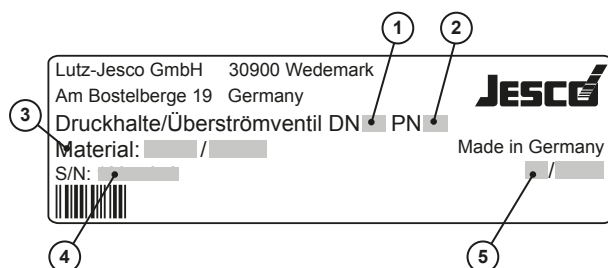

Fig. 1: Rating plate Back-pressure and pressure relief valves

No.	Description
1	Nominal width
2	Nominal pressure
3	Material housing / diaphragm
4	Serial number
5	Month / year of manufacture

Table 5: Rating plate

## 5 Technical data

Valve type	Nominal width	Material (housing)	Permitted operating pressure	Settable pressure	Max. temperature	Flow rate*
Back-pressure and pressure-relief valve (Diaphragm valve with spring loading)	DN6	PVC, PP, PVDF, stainless steel 1.4571	16 bar	0.5 - 16 bar	PVC: 35 °C PP/PVDF: 50 °C Stainless steel: 50 °C	75 l/h
	DN10		10 bar	0.5 - 10 bar		200 l/h
	DN15		10 bar	0.5 - 10 bar		500 l/h
	DN25	PP	10 bar	0.5 - 10 bar	PP: 50 °C Stainless steel: 50 °C	850 l/h
	DN25	Stainless steel 1.4571	16 bar	0.5 - 16 bar		850 l/h
	DN32	PP, stainless steel 1.4571	10 bar	0.5 - 10 bar		1400 l/h
	DN40	PP, stainless steel 1.4571	10 bar	0.5 - 10 bar		2250 l/h
	DN50	PP, stainless steel 1.4571	10 bar	0.5 - 10 bar		3600 l/h
DN65	PP	10 bar	0.5 - 10 bar	5000 l/h		
Pressure-relief valve (spring-loaded seat valve)	DN6	Stainless steel 1.4571	200 bar	0.9 - 1.7 bar ... 121 - 200 bar (comply with the information on the rating plate)	120 °C	40 l/h
	DN10		250 bar	4 - 6 bar ... 200 - 250 bar (comply with the information on the rating plate)	280 °C	480 l/h with 10 bar 1500 l/h with 100 bar
Mounting block	DN6	PVC, PP, PVDF, 1.4571	16 bar	0.5 - 16 bar	PVC: 35 °C PP/PVDF: 50 °C stainless steel: 50 °C	75 l/h
	DN10		10 bar	0.5 - 10 bar		200 l/h
	DN15		10 bar	0.5 - 10 bar		500 l/h

Table 6: Technical data

\* Applies to the uniform flow of water and other liquids with a viscosity and density comparable to water.

## 6 Dimensions

### 6.1 Valves DN6 - DN15 (spring-loaded diaphragm valve)

All dimensions in millimetres (mm).

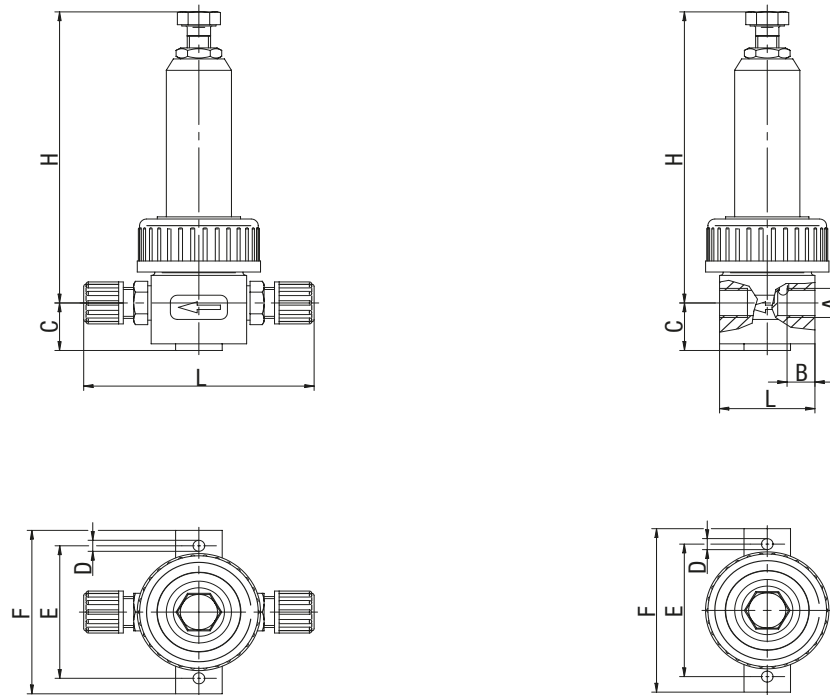

Fig. 2: Dimensioned drawing Back-pressure and pressure relief valves DN6 - DN15 (spring-loaded diaphragm valve)

Nominal width	Material	A	B	C	D	E	F	H	L	
DN6	Plastic	-	-	21.5	5	60	71	125 - 140	~140	
	Stainless steel*	-	-						100	
	Stainless steel	G1/4	12						41	
DN10	Plastic	G3/8	12	18	7	92	112	125 - 150	50	
		Grommet Ø13	-						128	
		Ø20	16						90	
	Stainless steel	G3/8	18						49	
		G1/2							107	
DN15	Plastic	G1/2	17	21	7	92	112	130 - 160	70	
		Grommet Ø16	-						156	
		Ø20	16						112	
		Ø25	19						120	
	Stainless steel	G1/2	25	18					140 - 165	74
		G3/4								130

\* with hose clamp connection in PVDF

### 6.2 Valves DN25 - DN65 (spring-loaded diaphragm valve)

All dimensions in millimetres (mm).

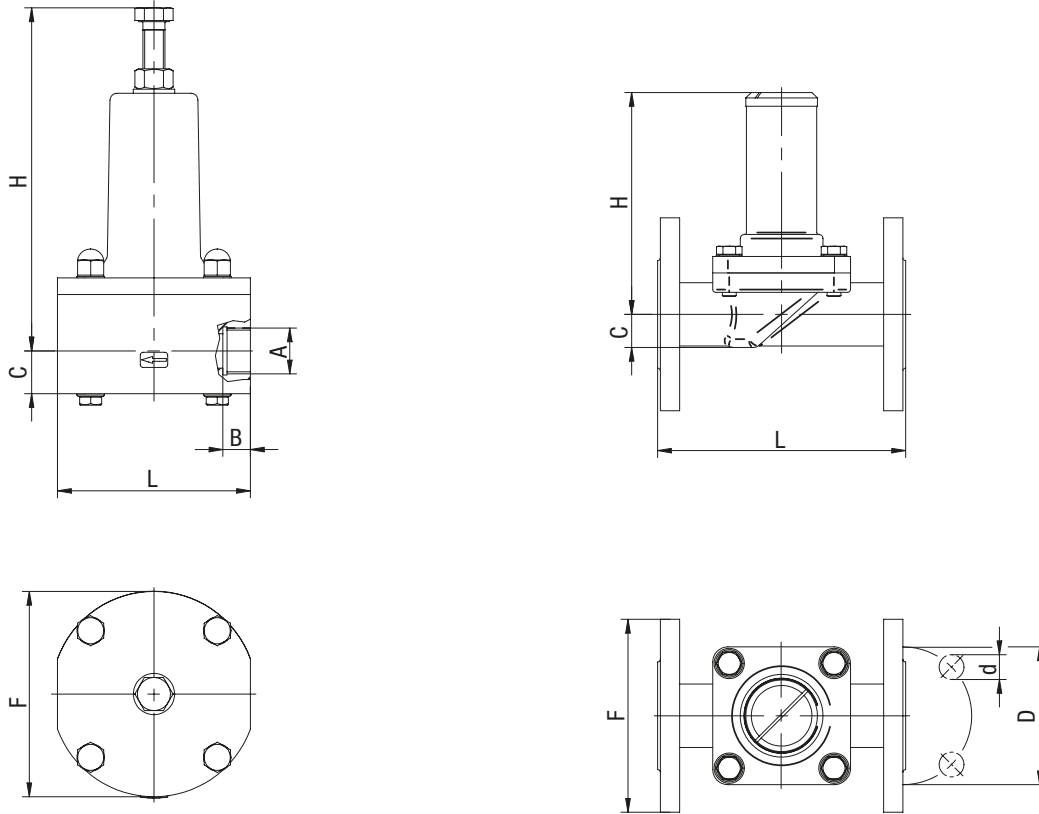

Fig. 3: Dimensioned drawing Back-pressure and pressure relief valves DN25 - DN65 (spring-loaded diaphragm valve)

Nominal width	Material	A	B	C	D	E	F	H	L
DN25	Plastic	G1	20	31	-	-	149	220 - 255	140
		Ø32	22						200
		Ø40	32						220
	Stainless steel	G1	30	22					140
DN32	Plastic	G1 1/4	22	31	-	-	149	220 - 255	140
	Stainless steel	DN32	-	24	100	18	140	160	200
DN40	Plastic	G1 1/2	22	38	-	-	159	240 - 270	152
	Stainless steel	DN40	-	30	110	18	150	180	235
DN50	Plastic	G2	27	38	-	-	170	240 - 270	156
	Stainless steel	DN50	-	38	125	18	165	185	260
DN65	Plastic	G2 1/2	28	46	-	-	190	260 - 295	172

### 6.3 Pressure-relief valve DN6 (spring-loaded seat valve)

All dimensions in millimetres (mm).

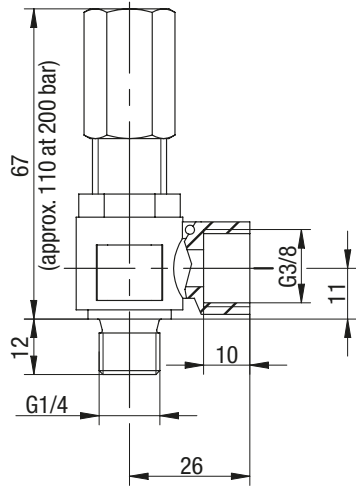

Fig. 4: Dimensioned drawing pressure-relief valve DN6 (spring-loaded seat valve)

### 6.4 Pressure-relief valves DN 10 (spring-loaded seat valve)

All dimensions in millimetres (mm).

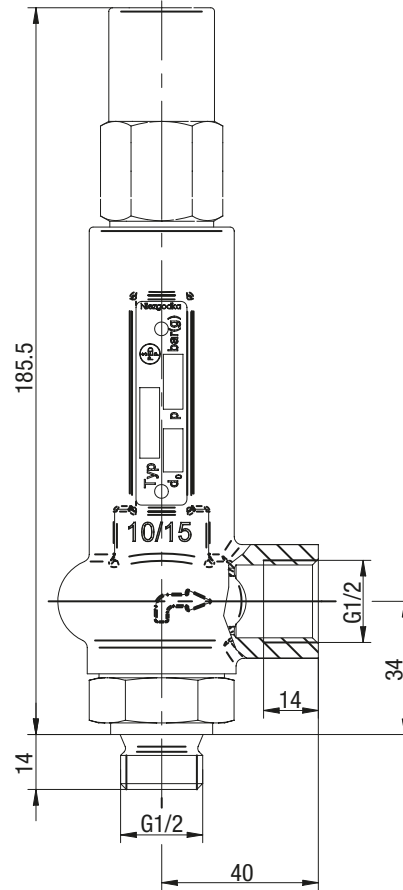

Fig. 5: Dimensioned drawing pressure-relief valve DN10 (spring-loaded seat valve)

### 6.5 Mounting block DN6

All dimensions in millimetres (mm).

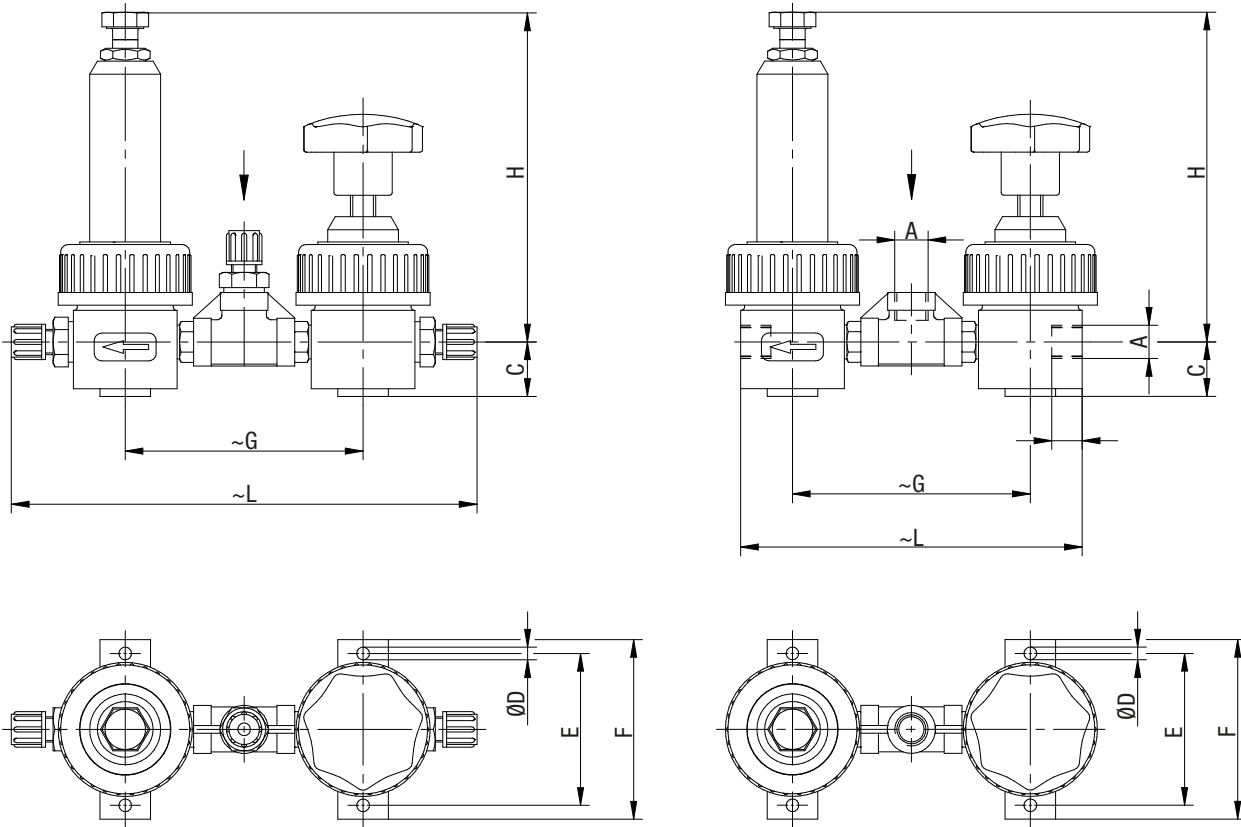

Fig. 6: Dimensioned drawing mounting block DN6

Nominal width	Material	A	B	C	D	E	F	G	H	L
DN6	Plastic	-	-	21.5	5	60	71	171	125 - 140	~320
	Stainless steel*	-	-					94		184
	Stainless steel	G1/4	12					135		

\* with hose clamp connection in PVDF

### 6.6 Mounting block DN10 – DN15

All dimensions in millimetres (mm).

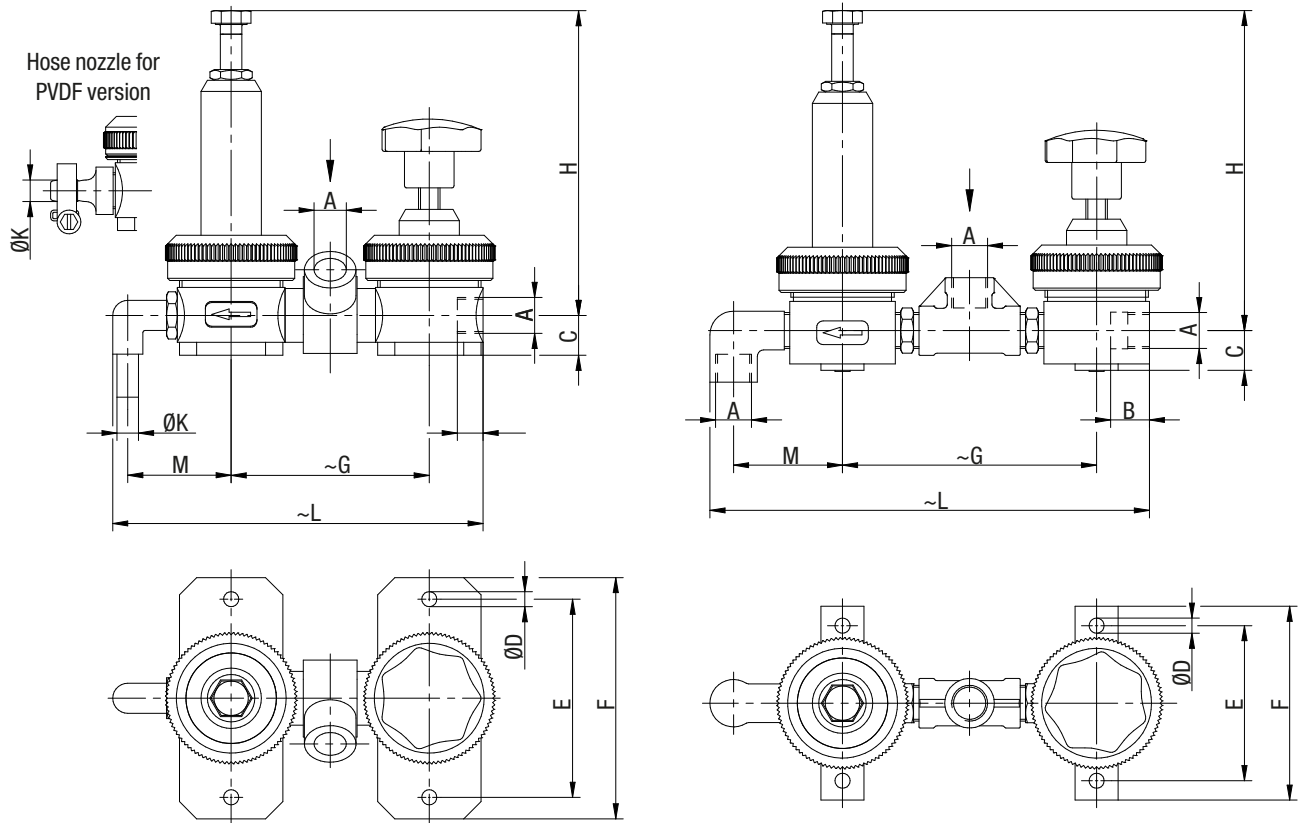

Fig. 7: Dimensioned drawing mounting block DN6

Nominal width	Material	A	B	C	D	E	F	G	H	K	M	L
DN10	Plastic	G3/8	12	18.5	7	92	112	92	125 - 150	10	48	172
	Stainless steel		18			72	90	118		-	50	204
DN15	Plastic	G1/2	16	21		92	112	112	130 - 160	12	66	222
	Stainless steel		25					136	140 - 165	-	57	240

## 7 Installation

### Principles

When installing, follow the basic principles below:

- Work in accordance with the flow direction of the back-pressure and pressure-relief valve (see Fig. 8).

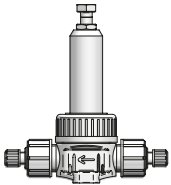

Fig. 8: Valve with arrow indicating the direction of flow

- Always fit the spring-loaded seat valve vertically. All other back-pressure and pressure-relief valves can be fitted in any installation position.
- A pressure gauge must be fitted in front of the valve in order to adjust the pre-tension pressure of the back-pressure and pressure-relief valves to the operating conditions of the dosing system.

### Installation with a back-pressure valve and pressure-relief valve

In the following installation example, a back-pressure valve (3) and a pressure-relief valve (4) is inserted. The return of the dosing medium leads into the suction line. In this case, there must not be a non-return valve or a foot valve in the suction line. You should install the pressure relief valve as close as possible to the dosing head.

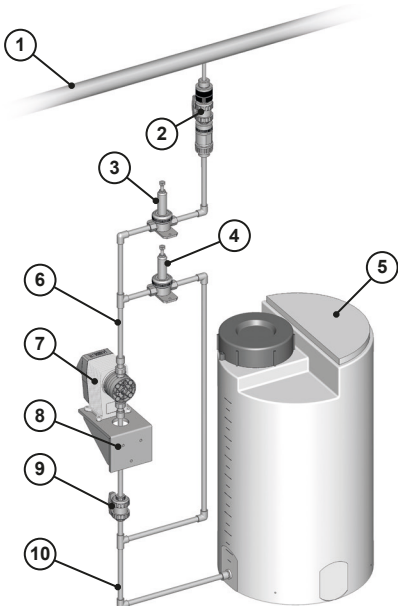

Fig. 9: Installation with a back-pressure valve and pressure-relief valve

Item	Description
①	Main line
②	Injection nozzle with shut-off valve
③	Back-pressure valve
④	Pressure-relief valve

Table 7: Designation of components

Item	Description
⑤	Dosing tank
⑥	Pressure line
⑦	Dosing pump
⑧	Wall bracket
⑨	Shut-off valve
⑩	Suction line

Table 7: Designation of components

### Installation with pressure relief valve – returning to the tank

Installation of a pressure-relief valve with return to the tank possible. The pressure in the dosing tank must not be too high so that it is possible to accommodate the returned dosing medium.

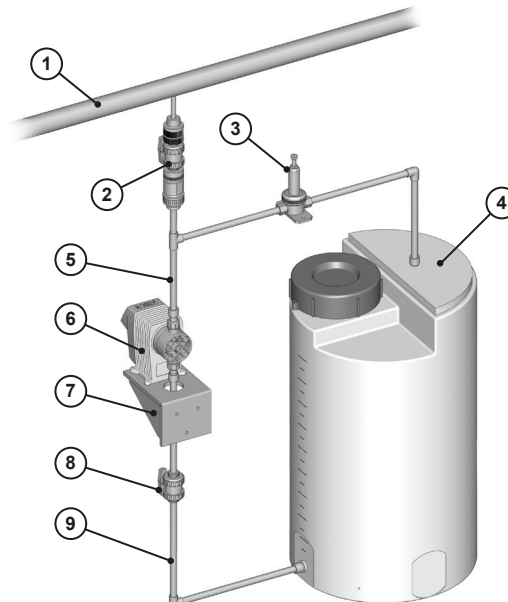

Fig. 10: Installation on the wall

Item	Description
①	Main line
②	Injection nozzle with shut-off valve
③	Pressure-relief valve
④	Dosing tank
⑤	Pressure line
⑥	Dosing pump
⑦	Wall bracket
⑧	Shut-off valve
⑨	Suction line

Table 8: Designation of components

## 8 Operation

### Setting the pre-tension pressure

Precondition for action:

- ✓ The entire system has been installed hydraulically and (if required) electrically.
- ✓ All the mechanical fastenings have been inspected to ensure adequate load-bearing capacity.
- ✓ All the hydraulic sections have been inspected to ensure they are adequately leak-proof and that the through flow direction is correct.
- ✓ The system is fitted with a pressure gauge to read off the operating pressure.
- ✓ Personnel have read all the operating instructions and understood them completely.



During initial start-up, use water as the dosing medium so as to check the leak-tightness of the system. Check first whether undesirable reactions could occur between the actual dosing medium and the water.

Perform the following working steps:

1. Loosen the counternut on the back-pressure and pressure-relief valve.
2. Turn the pressure setting screw anti-clockwise until it moves freely.
3. Open all the shutoff valves.
4. Startup the dosing pump. Increase the delivery capacity slowly to the required level.
5. Turn the pressure setting screw clockwise slowly.
  - ▶ The operating pressure increases.

When using as a back-pressure valve:

6. Once the desired operating pressure has been reached, screw the counternut clockwise until the pressure setting screw is no longer easy to loosen.
7. Check whether the operating pressure set remains constant over a long period.

When using as a pressure-relief valve:

6. Increase the inlet pressure tension until the pressure-relief valve does not open any further.
7. Turn the pressure setting screw c. half a revolution further to avoid any excess flow resulting from fluctuating operating pressures.

- ✓ **Pre-tension pressure set.**

## 9 Maintenance

Back-pressure and pressure relief valves are produced to the highest quality standards, and have a long service life. Nevertheless, some of their parts are subject to wear due to operation (e.g. diaphragms, valve seats, valve balls). This means that regular visual inspections are necessary to ensure a long operating life. Regular maintenance will protect the device from operation interruptions.



### NOTE

#### Function of the valve compromised

Tightening the union nut by hand means that the sufficient leak-tightness of the diaphragm has not been ensured. High pressures cannot be maintained in this fashion.

⇒ Use a suitable tool to tighten the union nut. Do not use any tools which could damage the components (e.g. a water pump wrench). Should you not have a suitable tool, the valve must be pre-tensioned lengthwise e.g. in a vice. The union nut can then be tightened by hand.

2. Unscrew the pressure setting screw from the valve cap (4).
3. Loosen the union nut (1).
4. Remove the valve cap.
5. Remove the diaphragm (8), spring plate (7), compression spring (6) and washer (5). Back-pressure and pressure relief valves with diaphragms made of FPM (Viton) and EPDM contain one diaphragm. Back-pressure and pressure relief valves DN6 with diaphragms made of EPDM-PTFE contain two diaphragms (10 and 11. Fig. 12).

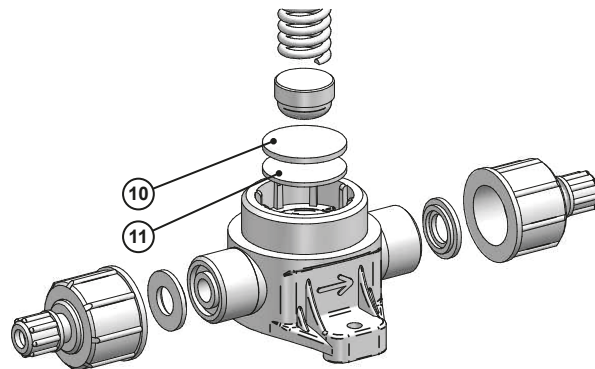

Fig. 12: Exploded view of back-pressure and pressure relief valves DN6 with diaphragms made of EPDM-PTFE

### 9.1 Valves DN6 - DN15 (spring-loaded diaphragm valve)

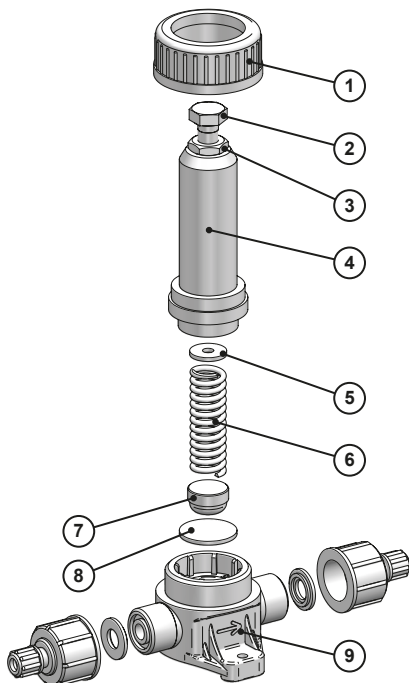

Fig. 11: Exploded diagram of the back-pressure and pressure-relief valves DN6 - DN15

Perform the following working steps:

1. Loosen the counter-nut (3) until the pressure setting screw (2) moves freely.



Measure the clearance of the pressure setting screw from the valve body and note the value. This enables you to set the identical pre-tension pressure after changing the diaphragm.

6. Clean the valve body (9).
7. Insert a new diaphragm (8 or 11) in the valve body with the coated side facing downwards. Should your back-pressure and pressure-relief valve be fitted with two diaphragms, insert an uncoated diaphragm (10) over it.
8. Insert the washer, compression spring and spring plate in the valve cap.
9. Insert the valve cap in the valve body.
10. Screw the union nut onto the valve body.
11. Screw the pressure setting screw in the valve cap with the counter-nut.
12. Set the specific pre-tension pressure.

✓ **Diaphragm has been replaced.**

## 9.2 Valves DN25 - DN65 (spring-loaded diaphragm valve)

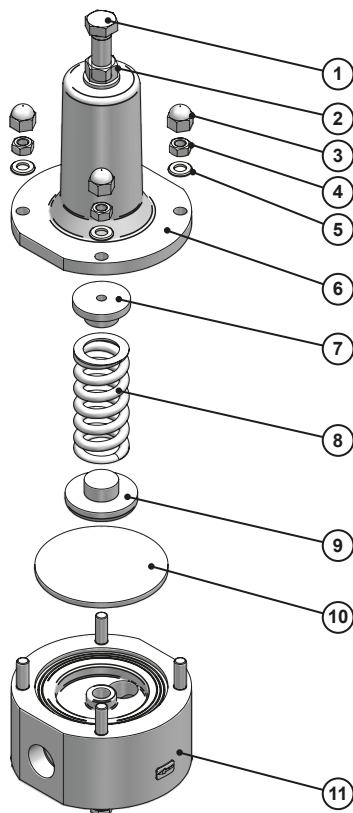

Fig. 13: Exploded diagram of the back-pressure and pressure-relief valves DN25 - DN65

Perform the following working steps:

1. Loosen the counternut (2) until the pressure setting screw (1) moves freely.

**i** Measure the clearance of the pressure setting screw from the valve body and note the value. This enables you to set the identical pre-tension pressure after changing the diaphragm.

2. Unscrew the pressure setting screw from the valve cap (6).
3. Remove the four protective caps (3).
4. Loosen the four hexagon nuts (4).
5. Remove the four washers (5).
6. Remove the valve cap.
7. Remove the diaphragm (10), diaphragm disc (9), compression spring (8) and spring plate (7).
8. Clean the valve body (11).
9. Insert a new diaphragm in the valve body with the coated side facing downwards.
10. Insert the spring plate, compression spring and diaphragm disc in the valve cap.
11. Place the valve cap on the valve body.
12. Insert the four washers.

13. Screw the four hexagon nuts tight. Tighten the hexagonal nuts equally in a criss-cross sequence. Recommended torque: 8 Nm
  14. Place the four protective caps on the hexagon nuts
  15. Screw the pressure setting screw in the valve cap with the counternut.
  16. Set the specific pre-tension pressure.
- ✓ **Diaphragm has been replaced.**

## 10 Spare parts

### 10.1 Diaphragms

Nominal width	Material (Casing)	Material (Membrane)	Part No.
DN6	PVC, PP, PVDF, 1.4571	EPDM-PTFE, PTFE	81905 26391
		EPDM	81898
		FPM	81899
DN10		EPDM-PTFE	81655
			81657 (for PVDF version)
DN15		EPDM-PTFE	81656
		EPDM	81562
		FPM	26394
DN25 - DN65		EPDM-PTFE	81662
	EPDM	81263	
	FPM	81264	

### 10.2 Seals

Material	Part number	Colour
EPDM	81824	Black
FPM	81825	Green
PTFE	81841	White

### 10.3 Seats for pressure-relief valve DN6

For stainless steel pressure-relief valve (see 6.3 "Pressure-relief valve DN6 (spring-loaded seat valve)" on page 13).

PVC	Size	Part No.
0.9 - 90.99	FPM	80085
91 - 200		80792

# 11 Declaration of Incorporation



**(DE) Einbauerklärung im Sinne der EG-Richtlinie 2006/42/EG über Maschinen (Anhang II B)**

Hiermit erklären wir, dass die nachstehend beschriebene unvollständige Maschine alle grundlegenden Anforderungen der Maschinenrichtlinie 2006/42/EG erfüllt, soweit es im Rahmen des Lieferumfangs möglich ist. Ferner erklären wir, dass die speziellen technischen Unterlagen gemäß Anhang VII Teil B dieser Richtlinie erstellt wurden. Wir verpflichten uns, den Marktaufsichtsbehörden auf begründetes Verlangen die speziellen Unterlagen zu der unvollständigen Maschine über unsere Dokumentationsabteilung zu übermitteln. Die unvollständige Maschine darf erst dann in Betrieb genommen werden, wenn ggf. festgestellt wurde, dass die Maschine oder Anlage, in welche die unvollständige Maschine eingebaut werden soll, den Bestimmungen der Richtlinie 2006/42/EG über Maschinen entspricht und die EG-Konformitätserklärung gemäß Anhang II A ausgestellt ist.

**(EN) Declaration of Incorporation according to EC directive 2006/42/EC on machinery (Annex II B)**

Herewith we declare, that the partly completed machinery described below is complying with all essential requirements of the Machinery Directive 2006/42/EC, as far as the scope of delivery allows. Additionally we declare that the relevant technical documentation is compiled in accordance with part B of Annex VII. We commit to transmit, in response to a reasoned request by the market surveillance authorities, relevant documents on the partly completed machinery by our documentation department. The partly completed machinery must not be put into service until the final machinery into which it is to be incorporated has been declared in conformity with the provisions of Directive 2006/42/EC on Machinery, where appropriate, and until the EC Declaration of Conformity according to Annex II A is issued.

**(FR) Notice de montage dans le cadre de la directive européenne 2006/42/CE relative aux machines (annexe II B)**

Nous expliquons ici que la machine incomplète décrite ci-après répond à toutes les exigences fondamentales de la directive relative aux machines 2006/42/CE, pour autant que cela soit possible dans le cadre du volume de livraison. Plus loin nous expliquons que les documents techniques spéciaux sont établis conformément à l'annexe VII partie B de cette directive. Pour ce qui est de notre service de documentation, nous nous engageons à communiquer aux autorités de surveillance du marché les explications fondées des documents spéciaux pour la machine incomplète. La machine incomplète doit d'abord être mise en service, quand il est constaté que la machine ou l'installation dans laquelle la machine incomplète doit être montée répond aux dispositions de la directive 2006/42/CE relative aux machines, et que la notice de conformité européenne est présentée conformément à l'annexe II A.

**(ES) Declaración de incorporación según la Directiva 2006/42/CE sobre máquinas (Anexo II B)**

Por la presente declaramos que la siguiente quasi máquina cumple con todas las disposiciones pertinentes de la Directiva 2006/42/CE de máquinas, siempre y cuando lo permita el volumen de suministro. También declaramos que la documentación técnica descrita en el anexo VII parte B se ha elaborado conforme a la presente Directiva. Nos comprometemos a enviar los documentos de la quasi máquina a las autoridades de vigilancia del mercado a través de nuestro departamento de documentación en respuesta a una previa solicitud motivada. La quasi máquina no puede ponerse en servicio sin antes verificar que la máquina o el sistema en el que se instale la quasi máquina, cumpla con las disposiciones de la Directiva 2006/42/CE de máquinas y con la declaración CE de conformidad según el anexo II A.

**(PT) Declaração de Construção de acordo com a Directiva-CE 2006/42/CE de máquinas (Anexo II B)**

Esclarecemos por meio deste que a máquina incompleta descrita a seguir segue os requerimentos da diretiva de máquinas 2006/42/CE, contanto que sua utilização seja mantida dentro do escopo original. Esclarecemos ainda que a documentação técnica especial segue o disposto no Anexo VII Parte B de tal diretiva. Comprometemo-nos a cumprir com as exigências das autoridades de fiscalização que forem feitas a nosso departamento de documentação que estejam relacionadas a qualquer documentação da máquina incompleta. A máquina poderá ser colocada em operação, se necessário for, desde que seja verificado que o sistema ou a máquina na qual a máquina incompleta será instalada foi montada, em conformidade com a diretiva 2006/42/CE de máquinas e com a declaração de conformidade 2006/42/CE.

Bezeichnung des Gerätes:	<b>Druckhalteventile Überströmventile</b>	Descripción de la mercancía:	<b>Válvulas de retención Válvulas de sobrecarga</b>
Description of the unit:	<b>Back-pressure valves Pressure-relief valve</b>	Designação do aparelho:	
Désignation du matériel:	<b>Soupape de contre-pression Soupape de sécurité</b>		
Typ / Type	<b>DN6 PN10, DN10 PN10, DN15 PN10, DN6 PN16, DN25 – DN65 PN10, DN25 PN16</b>		

Die unvollständige Maschine entspricht allen Bestimmungen der Richtlinie(n):  
The partly completed machine is in conformity with all requirements of the directive(s):

<b>2006/42/EG</b>	<b>Maschinenrichtlinie</b>	<b>Machinery Directive</b>
<b>97/23/EG</b>	<b>Druckgeräterichtlinie</b>	<b>Pressure Equipment Directive</b>

Folgende harmonisierte Normen wurden angewandt:  
The following harmonised standards were applied:

-



Lucjan Gogolin  
Leiter Dosiertechnik  
Head of Dosing Department  
Lutz-Jesco, Wedemark, 01.03.2013

Dokumentationsbevollmächtigter:  
Authorized person for documentation:  
Lucjan Gogolin  
Adresse: siehe Adresse des Herstellers  
Address: see manufacturer's address

Lutz-Jesco GmbH  
Am Bostelberge 19  
30900 Wedemark  
Germany

## 12 Declaration of no objection

Please copy the declaration, stick it to the outside of the packaging and return it with the device.

### Declaration of no objection

Please fill out a separate form for each appliance!

We forward the following device for repairs:

Device and device type: ..... Part-no.: .....

Order No.: ..... Date of delivery: .....

Reason for repair: .....  
 .....  
 .....

#### Dosing medium

Description: ..... Irritating:  Yes  No

Properties: ..... Corrosive:  Yes  No

We hereby certify, that the product has been cleaned thoroughly inside and outside before returning, that it is free from hazardous material (i.e. chemical, biological, toxic, flammable, and radioactive material) and that the lubricant has been drained.

If the manufacturer finds it necessary to carry out further cleaning work, we accept the charge will be made to us.

We assure that the aforementioned information is correct and complete and that the unit is dispatched according to the legal requirements.

Company / address: ..... Phone: .....

..... Fax: .....

..... Email: .....

Customer No.: ..... Contact person: .....

Date, Signature: .....

## 13 Warranty claim

### Warranty claim

Please copy and send it back with the unit!

If the device breaks down within the period of warranty, please return it in a cleaned condition with the complete warranty claim.

#### Sender

Company: ..... Phone: ..... Date: .....

Address: .....

Contact person: .....

Manufacturer order no.: ..... Date of delivery: .....

Device type: ..... Serial number: .....

Nominal capacity / nominal pressure: .....

Description of fault:.....

.....

.....

.....

.....

.....

.....

.....

.....

.....

.....

#### Service conditions of the device

Point of use / system designation:.....

.....

Accessories used (suction line etc.):.....

.....

.....

.....

.....

.....

Commissioning (date): .....

Duty period (approx. operating hours): .....

Please describe the specific installation and enclose a simple drawing or picture of the chemical feed system, showing materials of construction, diameters, lengths and heights of suction and discharge lines.

